



schwaben®

Steering Knuckle Pinch Bolt Tool

019527SCH01A



- 3 piece drift tool kit for Audi A4/A6 & VW Passat.
- This tool should also fit any VAG application (2008+) which is equipped with a 4-link front suspension.
- Designed to be used with an air chisel or air hammer.

Introduction

This 9mm Drift Tool Kit has been designed to assist in the removal of the steering knuckle pinch bolt on VW/Audi vehicles (2008+), but it can also be used for any procedure which requires a 9mm drift. This tool kit is meant to be used with an air chisel or air hammer, it is not meant to be used by hand.

Ref.	Part
A	Drift
B	Guide Bushing
C	Drift Extension

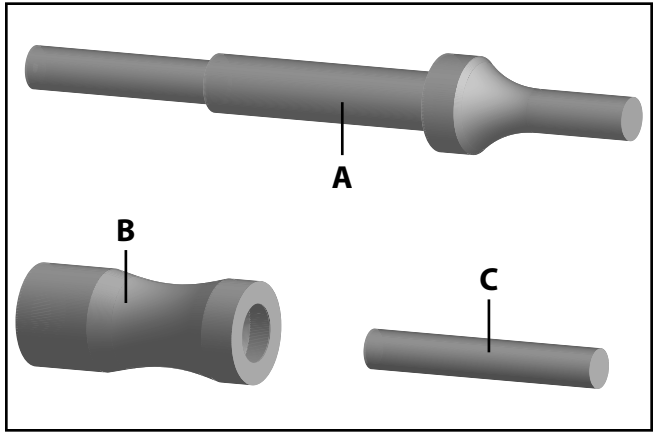

Instructions

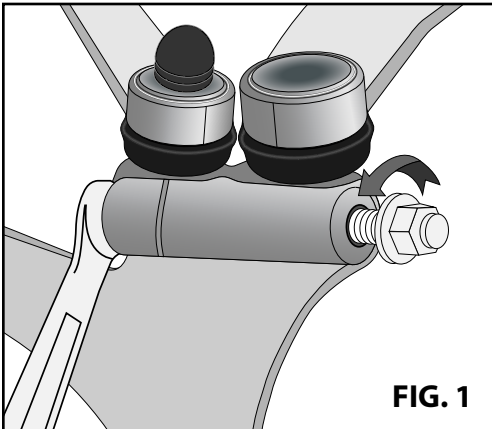

If necessary, rotate the steering wheel in order to access the pinch bolt with the Drift Tool mounted in an air chisel. Refer to **FIG. 1**, then loosen and remove the nut on the pinch bolt.

Instructions (cont.)

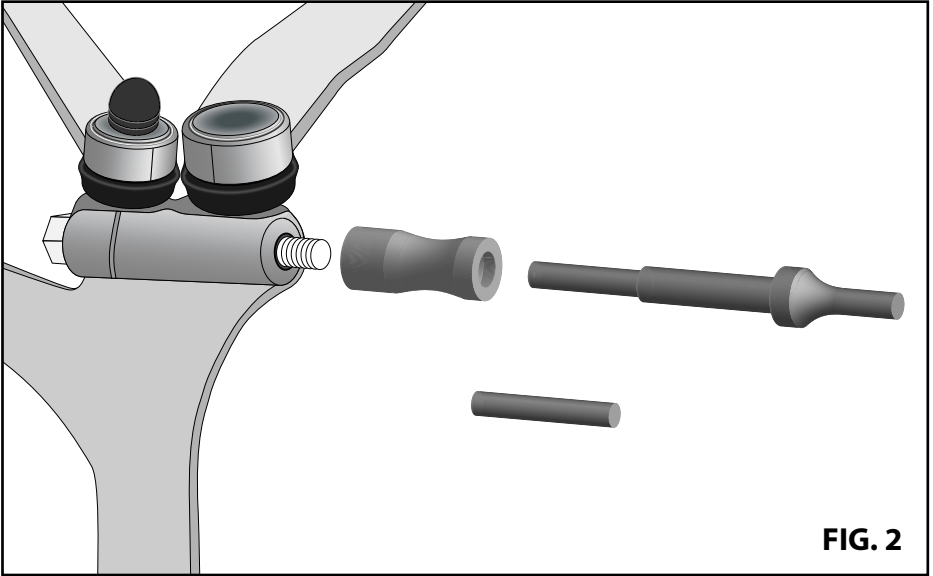

FIG. 2

(This tool has been designed in pieces for ease of access, and it will require three steps to completely remove the pinch bolt)

- 1.** Place the Guide Bushing over the exposed bolt threads (**FIG. 2**), this will prevent the threads from being damaged during removal. Place the Drift into the Guide Bushing, then use the air chisel to drive the pinch bolt out as far as possible. This first stage will move the pinch bolt by approximately 15mm.
- 2.** Next, remove the Guide Bushing and place the Drift directly into the pinch bolt hole and continue driving the bolt back with the air chisel. This stage will move the pinch bolt another 35mm.
- 3.** Finally, remove the Drift from the pinch bolt hole, insert the Drift Extension into the pinch bolt hole, and use the Drift to completely drive out the pinch bolt.

Safety Information

Use caution when using an air chisel or air hammer.

- Risk of vibration related injuries to the hands/arms.
- Limit tool usage to no more than 120 minutes in an 8 hour period.
- Always wear safety glasses and other personal protective equipment.