



AUDI B6/B7 A4 REAR WHEEL BEARING SERVICE KIT *INSTALLATION TUTORIAL*

ES2561175



THIS TUTORIAL IS PROVIDED AS A COURTESY BY ECS TUNING.

PROPER SERVICE AND REPAIR PROCEDURES ARE VITAL TO THE SAFE, RELIABLE OPERATION OF ALL MOTOR VEHICLES AS WELL AS THE PERSONAL SAFETY OF THOSE PERFORMING THE REPAIRS. STANDARD SAFETY PROCEDURES AND PRECAUTIONS (INCLUDING USE OF SAFETY GOGGLES AND PROPER TOOLS AND EQUIPMENT) SHOULD BE FOLLOWED AT ALL TIMES TO ELIMINATE THE POSSIBILITY OF PERSONAL INJURY OR IMPROPER SERVICE WHICH COULD DAMAGE THE VEHICLE OR COMPROMISE ITS SAFETY. ALTHOUGH THIS MATERIAL HAS BEEN PREPARED WITH THE INTENT TO PROVIDE RELIABLE INFORMATION, NO WARRANTY (EXPRESS OR IMPLIED) IS MADE AS TO ITS ACCURACY OR COMPLETENESS. NEITHER IS ANY LIABILITY ASSUMED FOR LOSS OR DAMAGE RESULTING FROM RELIANCE ON THIS MATERIAL. SPECIFICALLY, NO WARRANTY OF MERCHANTABILITY, FITNESS FOR A PARTICULAR PURPOSE OR ANY OTHER WARRANTY IS MADE OR TO BE IMPLIED WITH RESPECT TO THIS MATERIAL. IN NO EVENT WILL ECS TUNING, INCORPORATED OR ITS AFFILIATES BE LIABLE FOR ANY DAMAGES, DIRECT OR INDIRECT, CONSEQUENTIAL OR COMPENSATORY, ARISING OUT OF THE USE OF THIS MATERIAL.

Product Description

The Schwaben® Audi Quattro Rear Wheel Bearing Service kit removes and installs rear wheel bearings on B6/7 Audi A4 Quattro models that use a pressed-in bearing. The tool may be used with the rear knuckle (bearing holder) installed in the car, or with the holder removed from the vehicle and mounted in a special jig or vise.

The bearing removal kit includes a large threaded jack screw, three sizes of circular press plates, a hollow receiver cup, plus press plate attachment screws and press bolts.

The horseshoe-shaped press plate is a special addition to this kit, allowing you to remove the drive hub from the wheel bearing, on or off the car.



Tools Used

- long breaker bar
- miscellaneous ratchets, extensions
- hanger to support caliper
- common screwdriver
- 5mm hex driver
- 8mm hex driver
- 17mm hex head driver
- M10 long reach triple square
- 17mm socket
- 18 mm socket
- 18mm combination wrench
- 22mm socket
- 32mm box wrench
- 32mm socket
- T27 Torx bit
- impact gun
- wire brush
- hammer
- pry bar

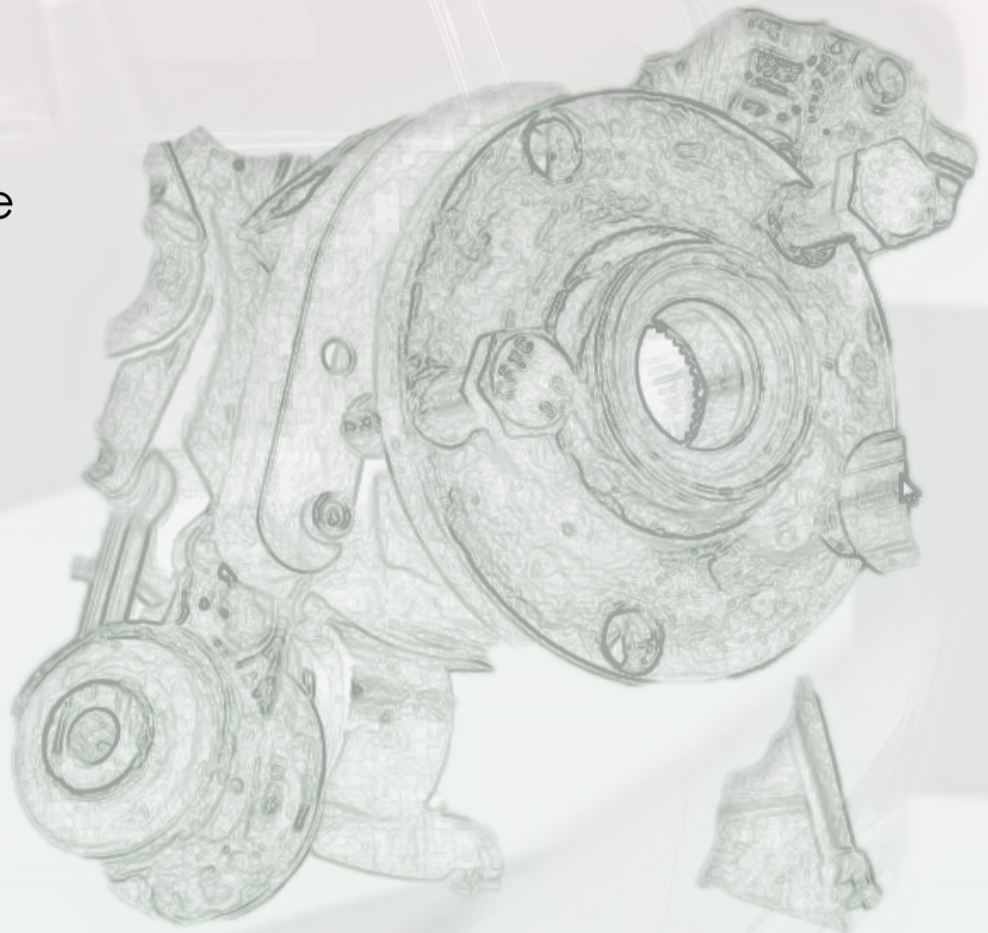

Tightening Specifications

- shoulder bolt - M14 - 115Nm; M16 - 200 Nm (Both to be torqued, then turned an additional 180 degrees with vehicle resting on wheels)
- CV joint-to-drive axle hub (M8 - 40Nm; M10 - 70Nm)
- caliper carrier to bearing housing (70Nm (+90 degrees) always replace bolt.
- bearing housing lower bolts/nuts (65Nm)

Note: This tutorial is broken into two sections: a photo pictorial starting on the next page and a Quick Reference section showing how the press tool is installed on the bearing housing, beginning on page 12. Final assembly procedures are listed on page 16.

Step 1

Use a small prying tool, remove the wheel center cap.

Apply the hand brake so the car cannot move.



Step 2

With the car sitting on the wheels, reach in with a 17mm hex-head driver and loosen the axle bolt.

The axle bolt is a torque-to-yield bolt and should be very tight. Use a long-handled breaker bar; be prepared to apply significant force to loosen the bolt.



Step 3

Remove the lug bolts.

Remove the wheel.



Step 4

Remove the rotor set screw. If your old set screw is corrosion-damaged, you may need an impact driver and Phillips bit to remove it.

NOTE: The wheel stud at the 12 o'clock position. This handy tool screws into a bolt hole by hand. It supports the wheel to make wheel removal and installation much easier and safer.

Click on ES numbers pictured right for stainless steel rotor screws and wheel hanger tool.

Step 5

Reach around to the backside of the brake caliper and unbolt it from the bearing holder.

There are two bolts with 8mm hex heads.

(Note: If you want to remove the brake caliper and rotor as an assembly, leave the hand brake applied, locking the caliper and rotor together.)

Step 6

Remove the brake rotor and caliper; hang them off to the side, out of your way.

Unbolt and remove the brake rotor dust shield from the bearing holder.

CAUTION: Support the brake assembly with a strong hanger. Do not use a weak hanger that may slip, allowing the weight of the brake assembly to hang from the brake hydraulic hose. Doing so may stress the hose and damage it, rendering it unsafe.

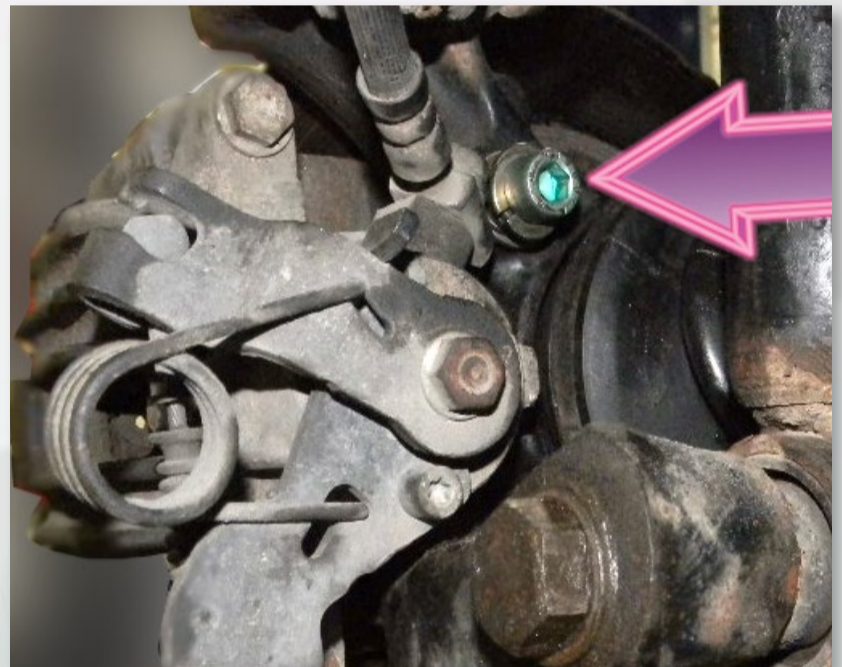

Step 7

Use a 5mm hex driver to remove the screw from the wheel speed sensor.

Pull the sensor out of the bearing holder housing. (Some twisting may be needed if the sensor is corroded in place; be careful not to damage the sensor or its wiring.) Remove the axle bolt.



Step 8

Use an M10 triple-square driver to unbolt the inner CV joint from the differential drive hub.

After removing the axle from the hub, pull the axle off to the side. This makes it easier to slide the outboard end of axle assembly out of the wheel hub.

(Note: The press tool cannot be mounted until the axle shaft is removed from the wheel bearing.)



Step 9

Place a jack under the control arm and raise it slightly.

Loosen and remove the fasteners connecting the control arm to the bearing holder (knuckle). Use two 18mm wrenches.

CAUTION: Do not lift the car off the jack

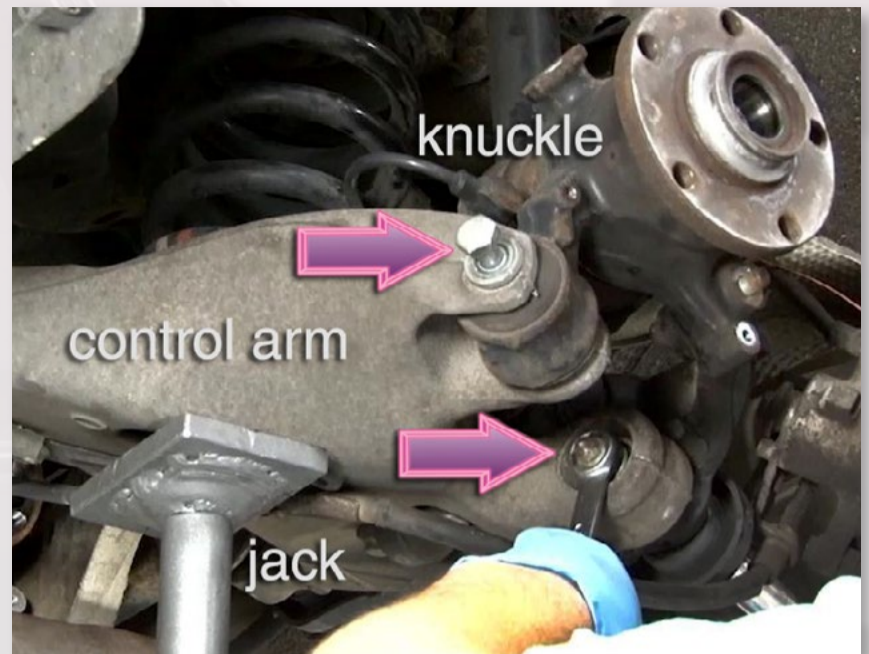

Step 10

Pry the bearing holder (knuckle) up and away from the control arm far enough that you can slide the outer CV joint out of the hub.

See the next photo for an important caution.



Step 11

Caution Remove the outer drive joint carefully. Do not damage the square windows in the tone ring cage (arrow). This is the reluctor wheel that the ABS sensor reads.

(FYI: The speed signal is used by the ABS and other onboard controllers. If it is bent or otherwise damaged, it will illuminate the ABS dashboard warning light, and disable Anti-Lock braking.)

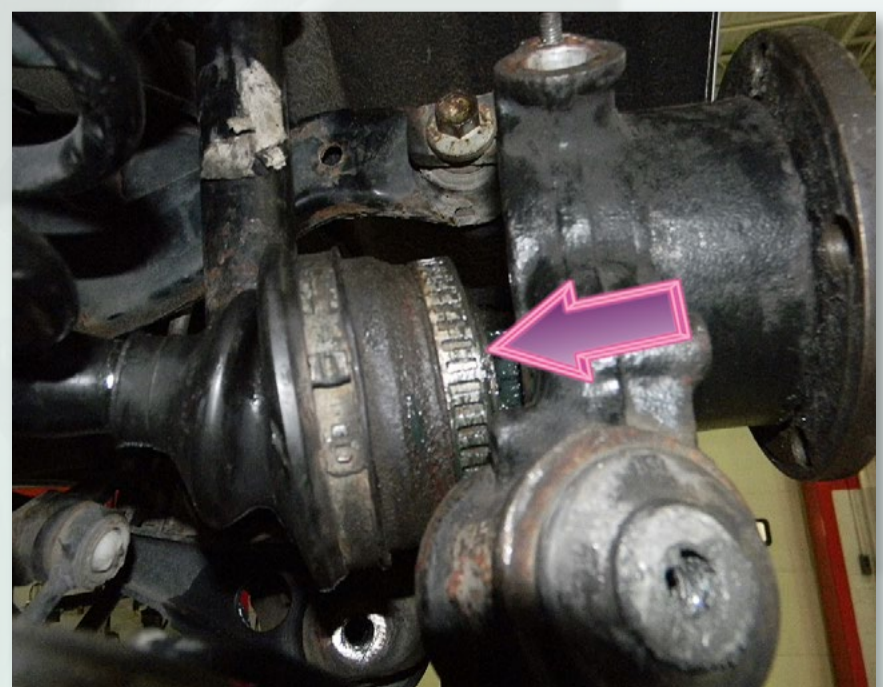

Step 12

Slide the open end of the horseshoe press plate over the neck of the hub.

Take the two small machine screws from the kit case. Using the brake rotor shield threaded holes, bolt the press plate onto the bearing holder (knuckle).



Step 13

- Apply clean grease liberally to the three large press bolts in the kit.
- Thread the bolts into the hub by hand until all three contact the horseshoe press plate.
- Using a wrench, alternately tighten each bolt to apply even pressure against the press plate.



Step 14

- Continue to tighten the bolts until the hub is pressed from the wheel bearing.
- Remove the bolts from the hub.
NOTE: Half of the wheel bearing's inner race may remain stuck to the hub. In this event, use a vise to secure the hub in place, and using a crowbar or chisel, pry the bearing race off of hub.

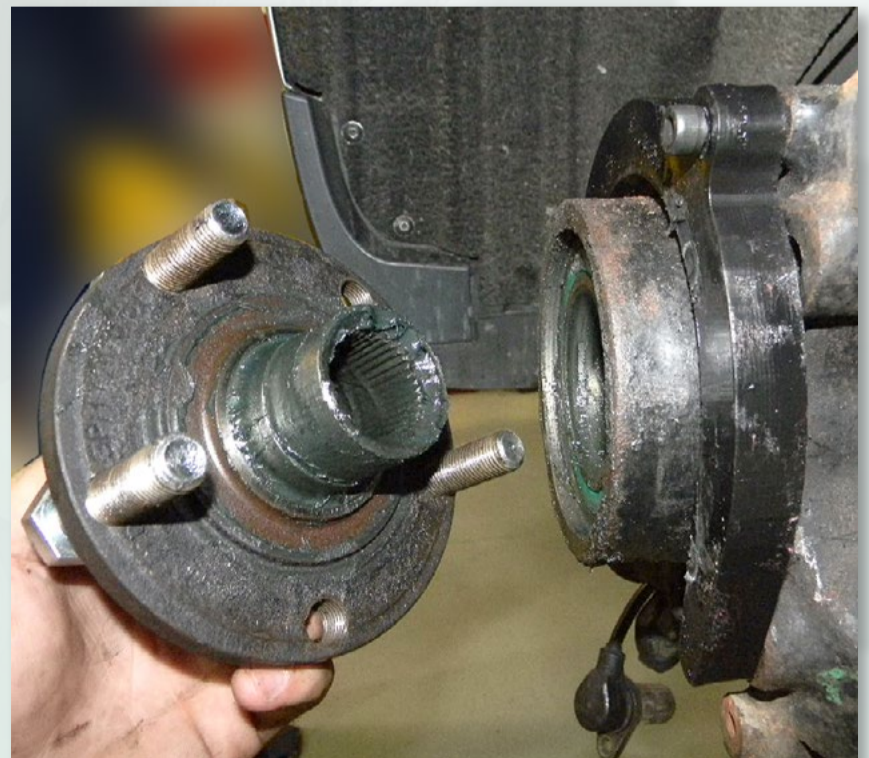

Step 15

Slide the jack screw through the hole in the 78mm plate; then slide the assembly through the bearing hole.

The bolt head should be inboard, with the threaded end facing outward, as shown.

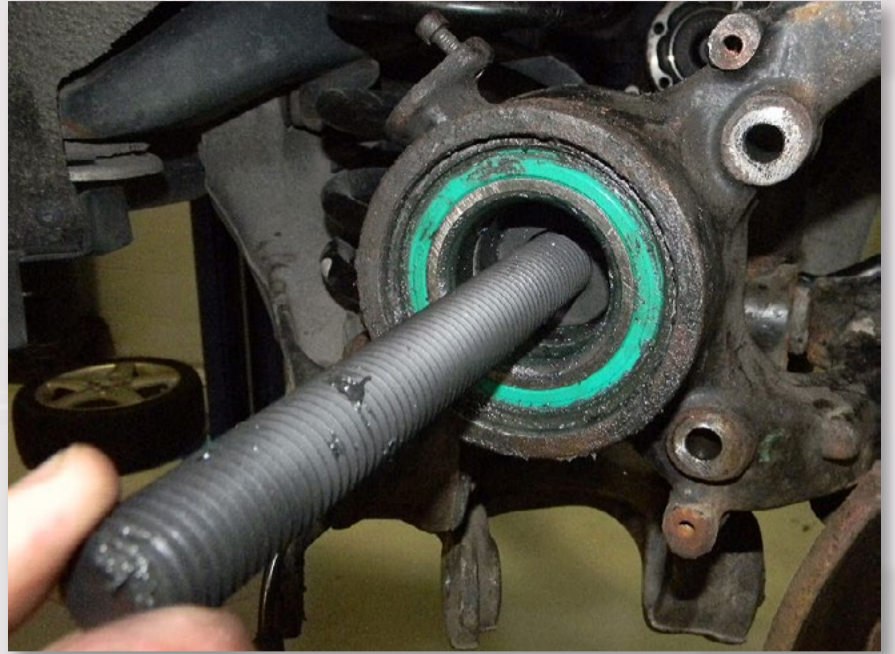

Step 16

- Install the hollow bearing receiver cup onto the bearing holder. The cup should be centered on the face of the bearing holder, chamfered side in.
- Lube the jack screw threads liberally with clean grease. Install the large plate, the thrust washer, and the large nut onto the jack screw as shown.

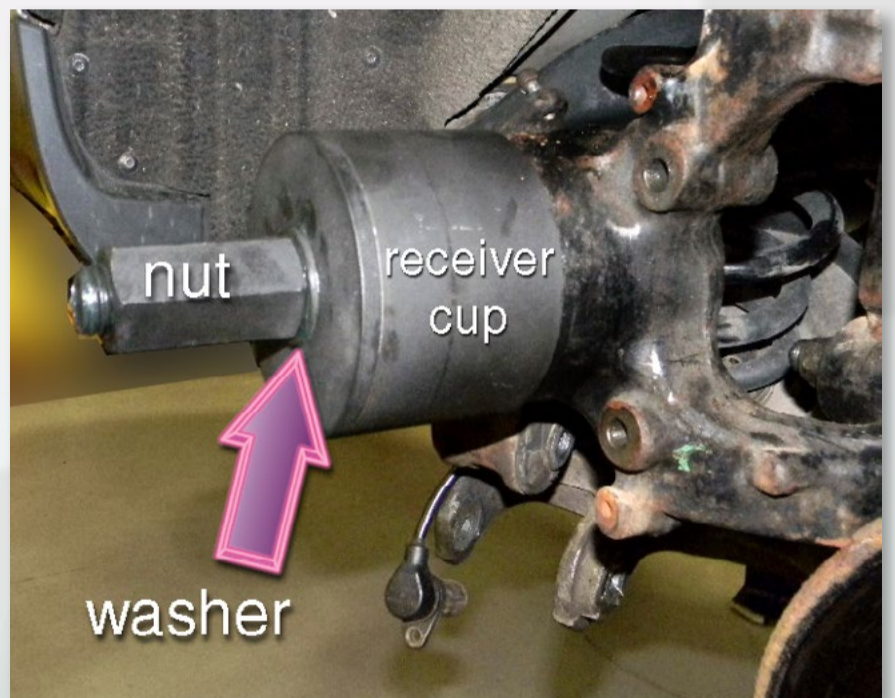

Step 17

- Turn the nut with a 32mm open or box wrench. As you do, the inner press plate will draw the bearing out of the bearing holder (knuckle), into the hollow receiver cup.
- When the bearing is fully removed, back off the nut, and separate the parts of the press tool. Remove the old bearing from the receiver cup.



Step 18

- Clean the bearing bore. Remove all rust and dirt. The bore should be shiny clean and free from nicks or burrs. Polish away small imperfections with emery paper or an abrasive cleaning disc (Roloc™ or similar).
- Apply a thin film of grease to the bore.

Note: The inner ledge in the bore (arrow) limits bearing penetration when pressing in the new bearing.



Step 19

The wheel bearing assembly contains two bearings. One of the inner bearing races has a larger inside diameter.

The larger diameter race must face outward when installing the bearing assembly to accept the stepped neck on the drive hub.



Step 20

To install the new bearing, reverse the positions of the two round press plates. This time, install the larger plate inboard. Install the smaller 78mm plate outboard, as shown, making sure the plate is centered on the bearing.

Slide the thrust washer over the screw jack.

Thread the large nut onto the screw by hand until it contacts the press plate. Then turn the nut with the wrench to draw the bearing into the bore.

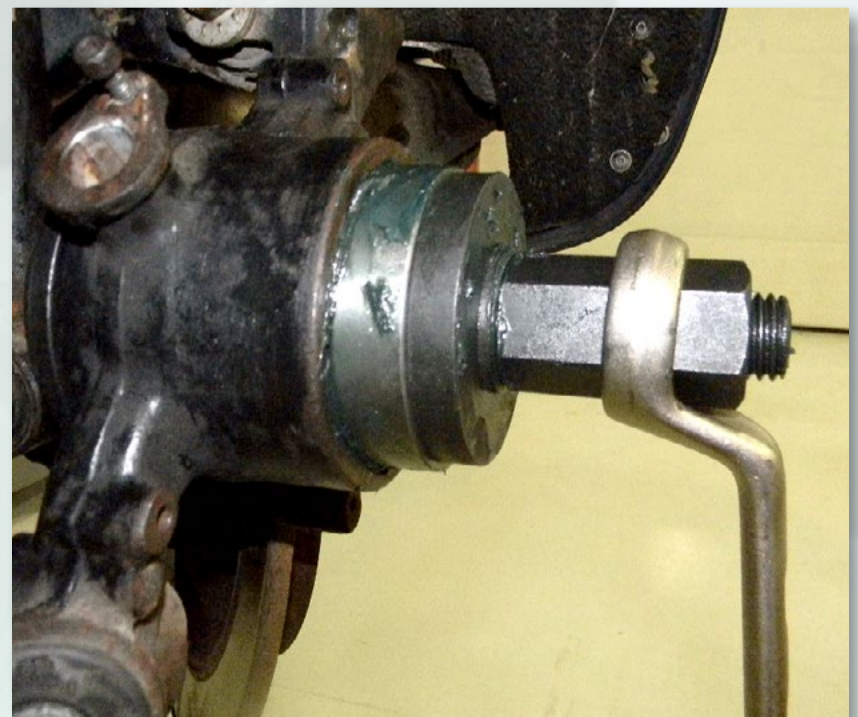

Step 21

Installing the bearing will require significant effort. When it becomes very difficult to move the nut at all, the bearing is installed.

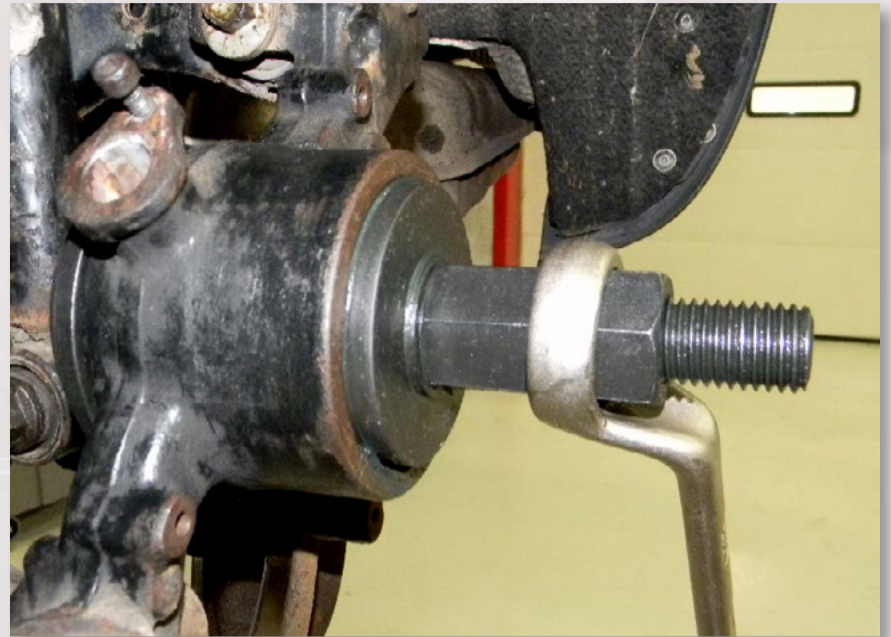

Step 22

Apply clean grease to the hub snout and inner bearing races.



Step 23

Align the hub with the center bore of the bearing. Install the 78mm small press plate on the screw jack bolt, then slide the bolt through the bearing hole, from the back.

NOTE: The flat face of the small plate should press only against the inner race of the inner bearing.

- Slide the larger press plate onto the threaded jack, over the hub.
- Slide the thrust washer onto the shaft and screw the large nut all the way down by hand.
- Use a 32mm wrench to turn the nut farther, drawing the hub into the bearings.

See page 15 for an illustrated side view.

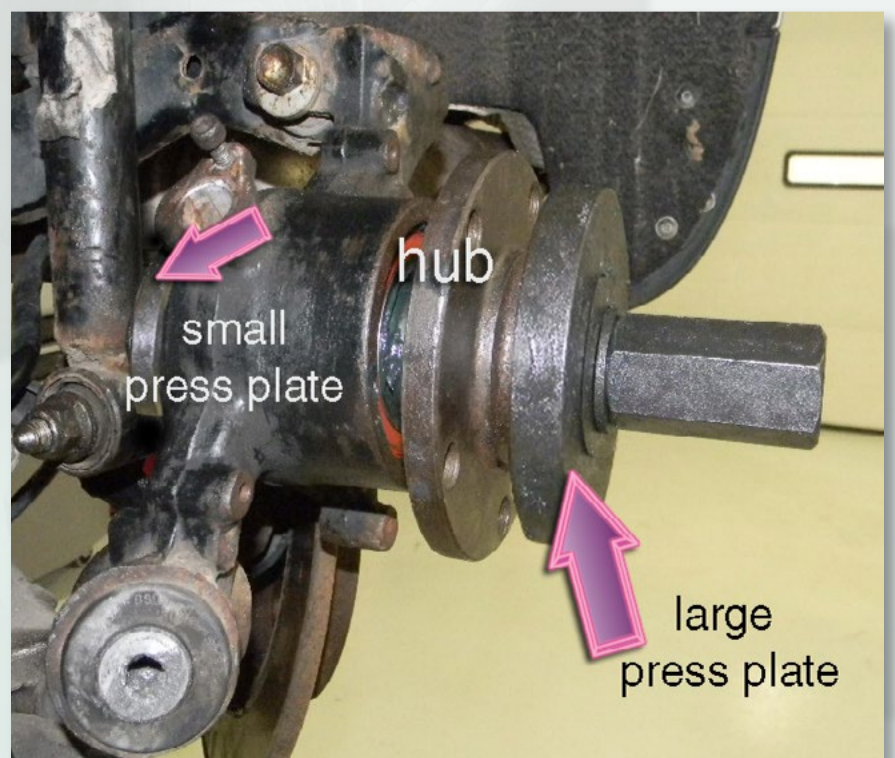

QUICK REFERENCE GUIDE

Main Suspension Components

Disassemble these components before installing and using the bearing press tool.

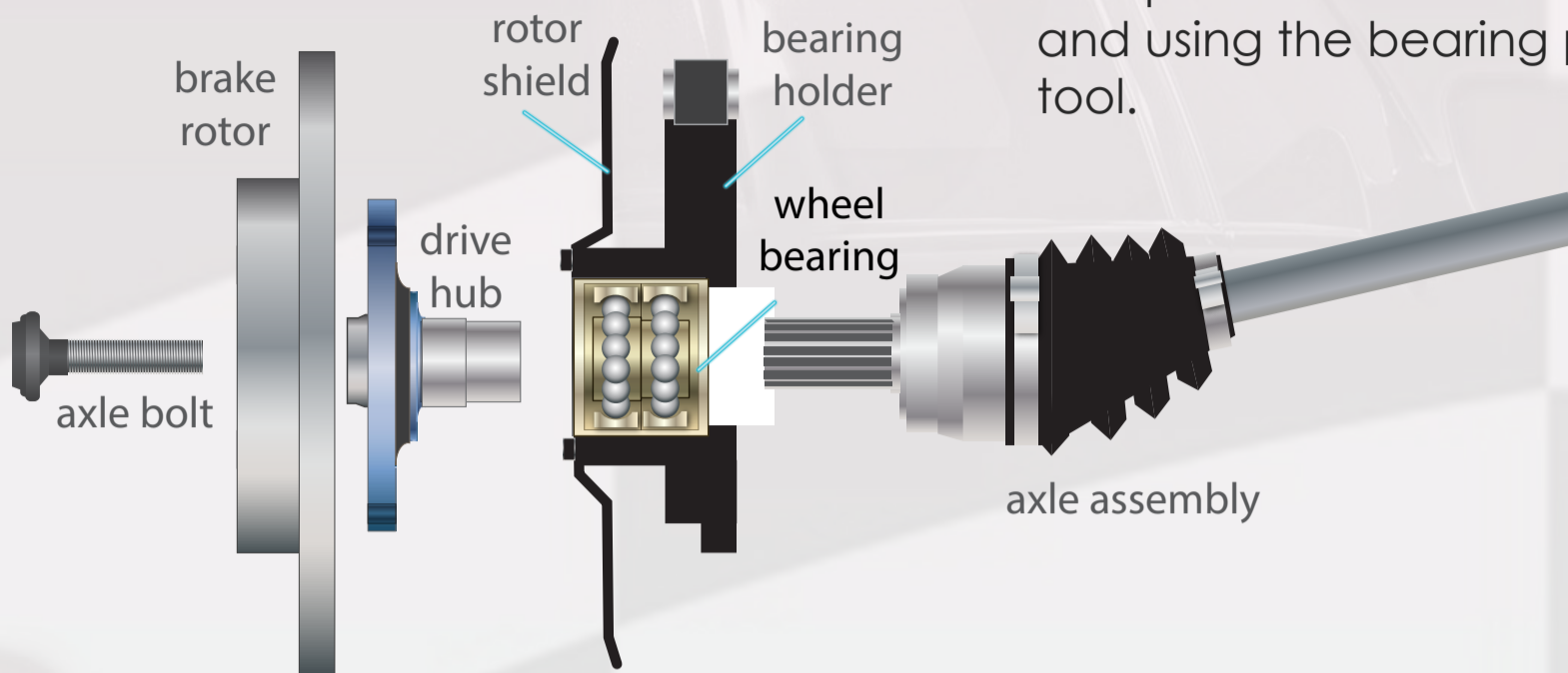

Press off Wheel Hub

The horseshoe tool slides behind the hub to create three press points.

Thread the bolts into the hub and screw them against the horseshoe plate to remove the hub from the bearing.

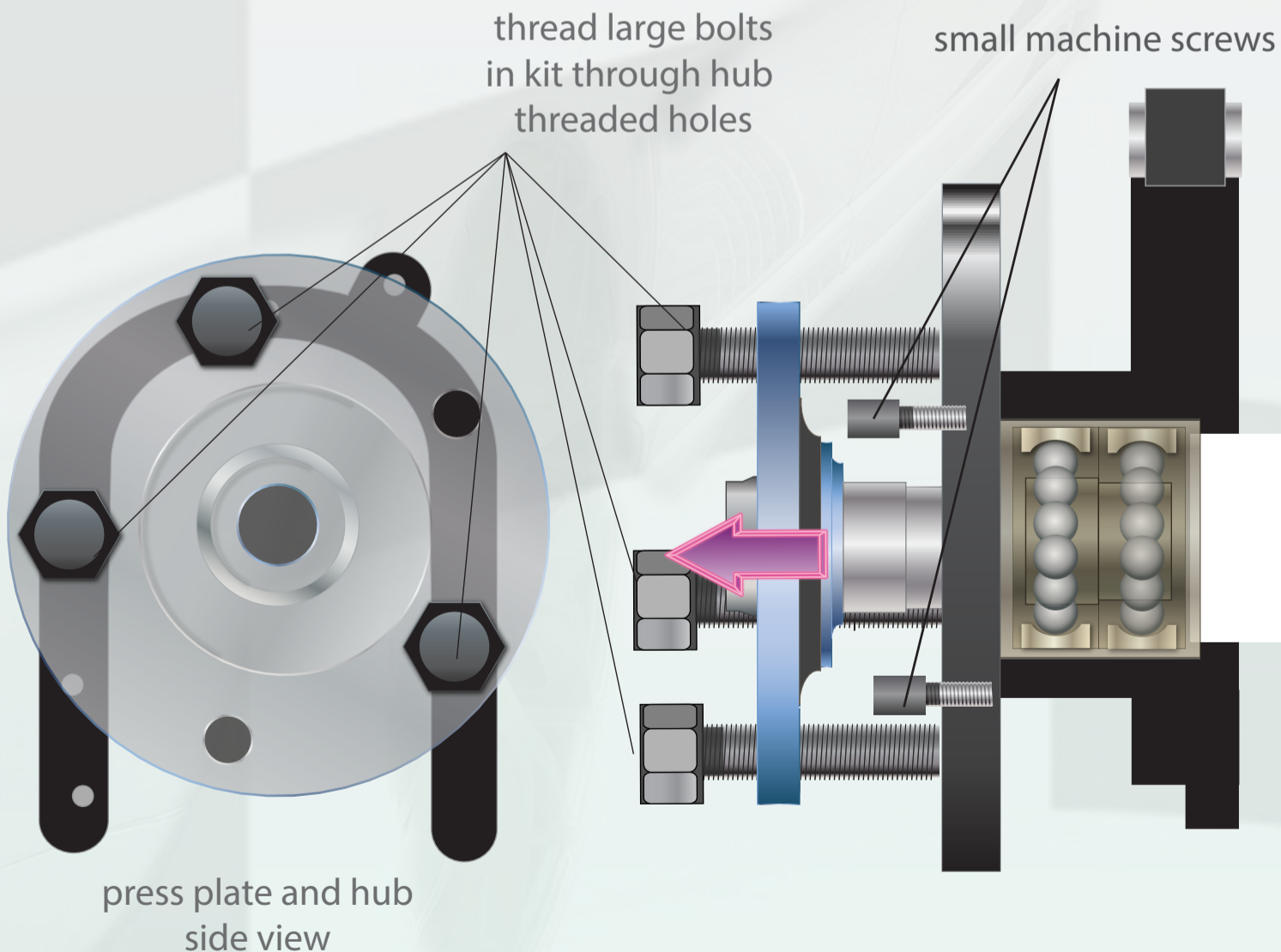

Remove Old Bearing

1 Assemble Tool

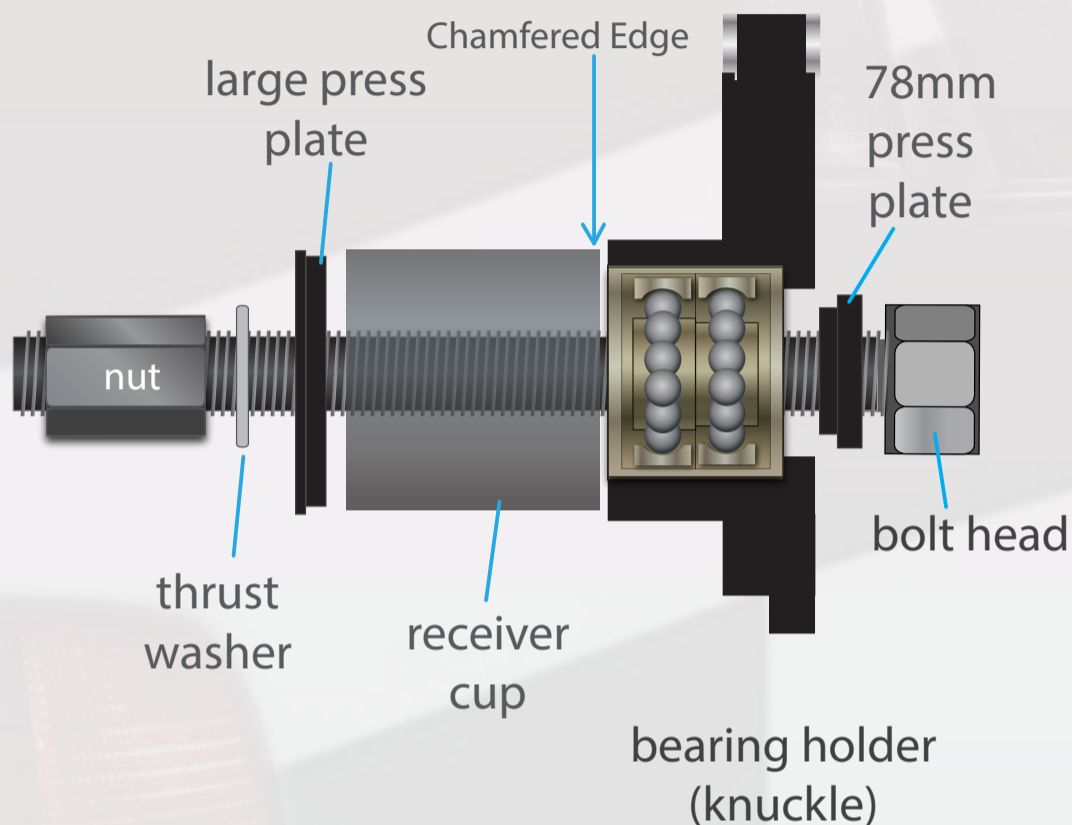

Assemble the tool as shown.
Lube threads, nut, and washer
with grease.

2 Press Out Bearing

Hold the bolt head as you
turn the nut to draw the press
plate against the bearing.

This will press the bearing from
the bearing holder into the
receiver cup.

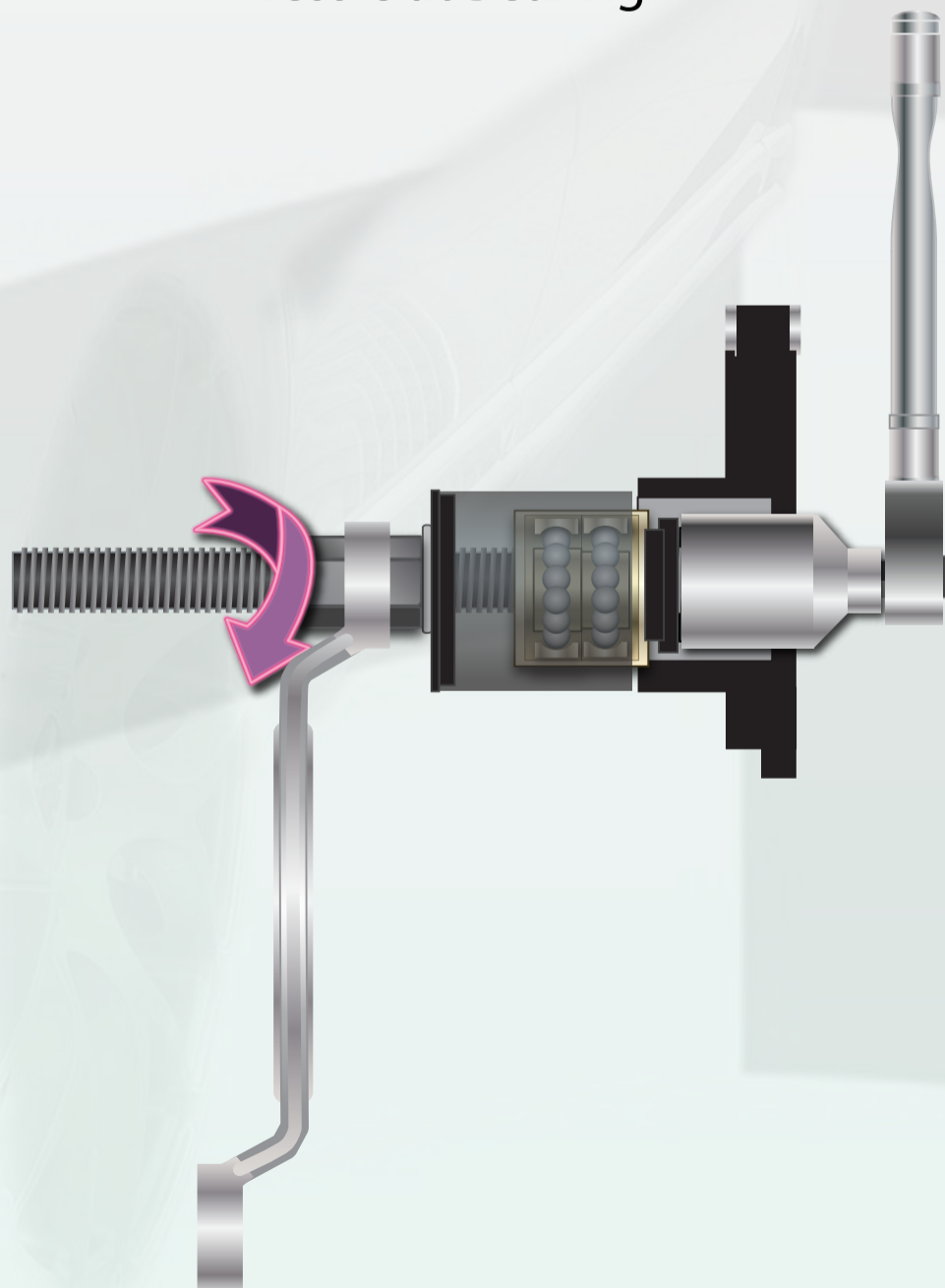

Press In New Bearing

3 clean and lube bore

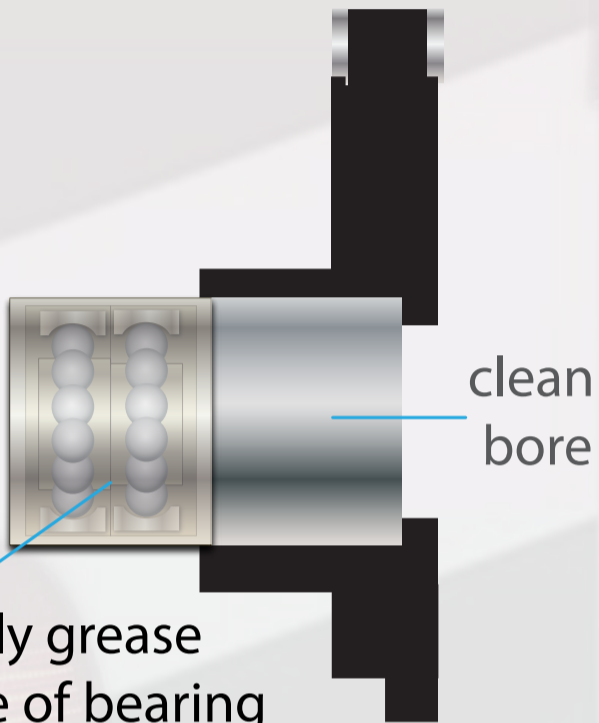

Reverse the process to install the new bearing. Make sure the bearing and bore are clean and lubed with a film of clean grease.

4 press in bearing with 78mm Plate

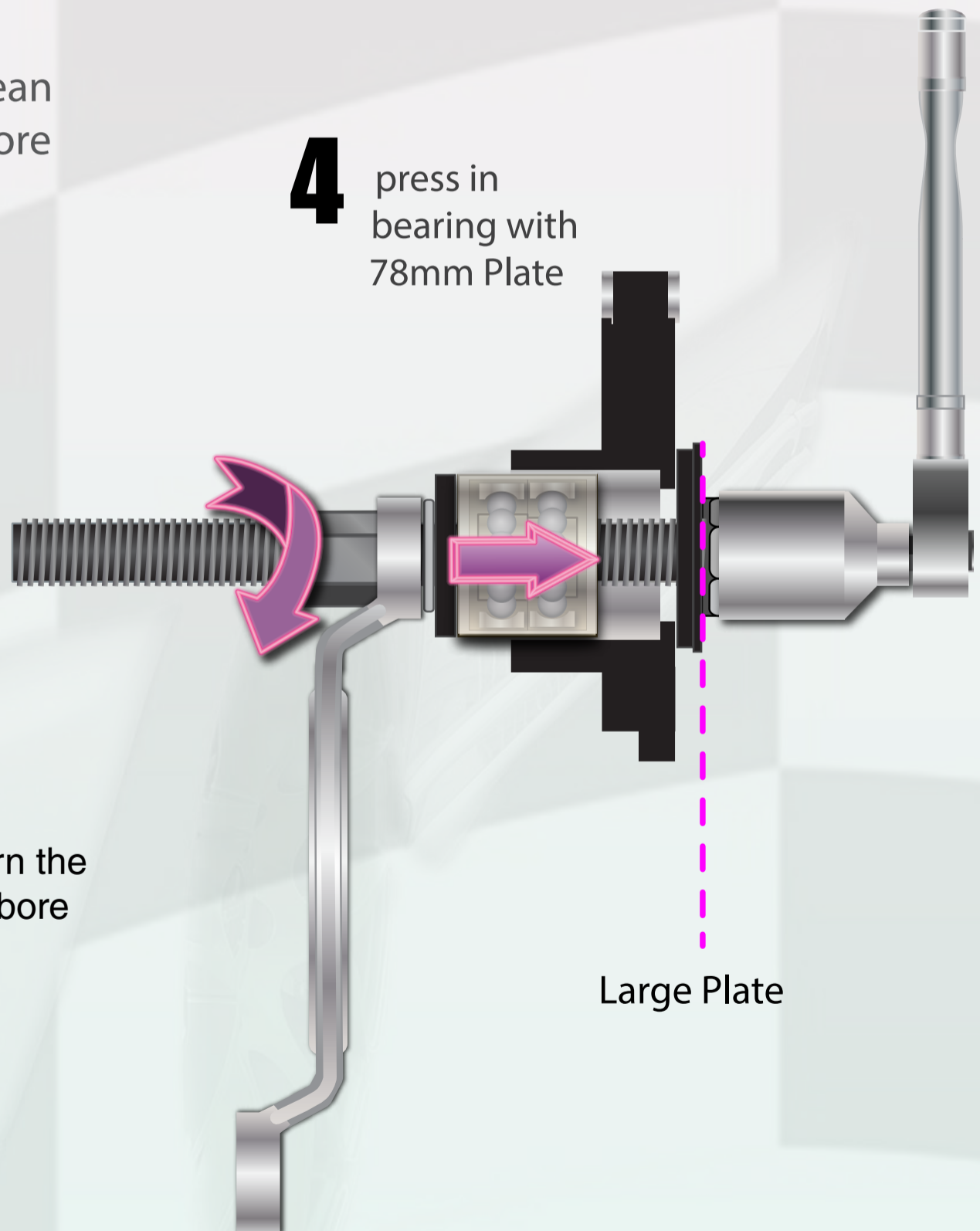

Assemble the tool as shown. Turn the nut to draw the bearing into the bore until it bottoms (dotted line).

Large Plate

Press in the Hub

Reinstall the brake rotor dust shield on the bearing holder. Align the hub with the bearing opening. Assemble the press tool as shown.

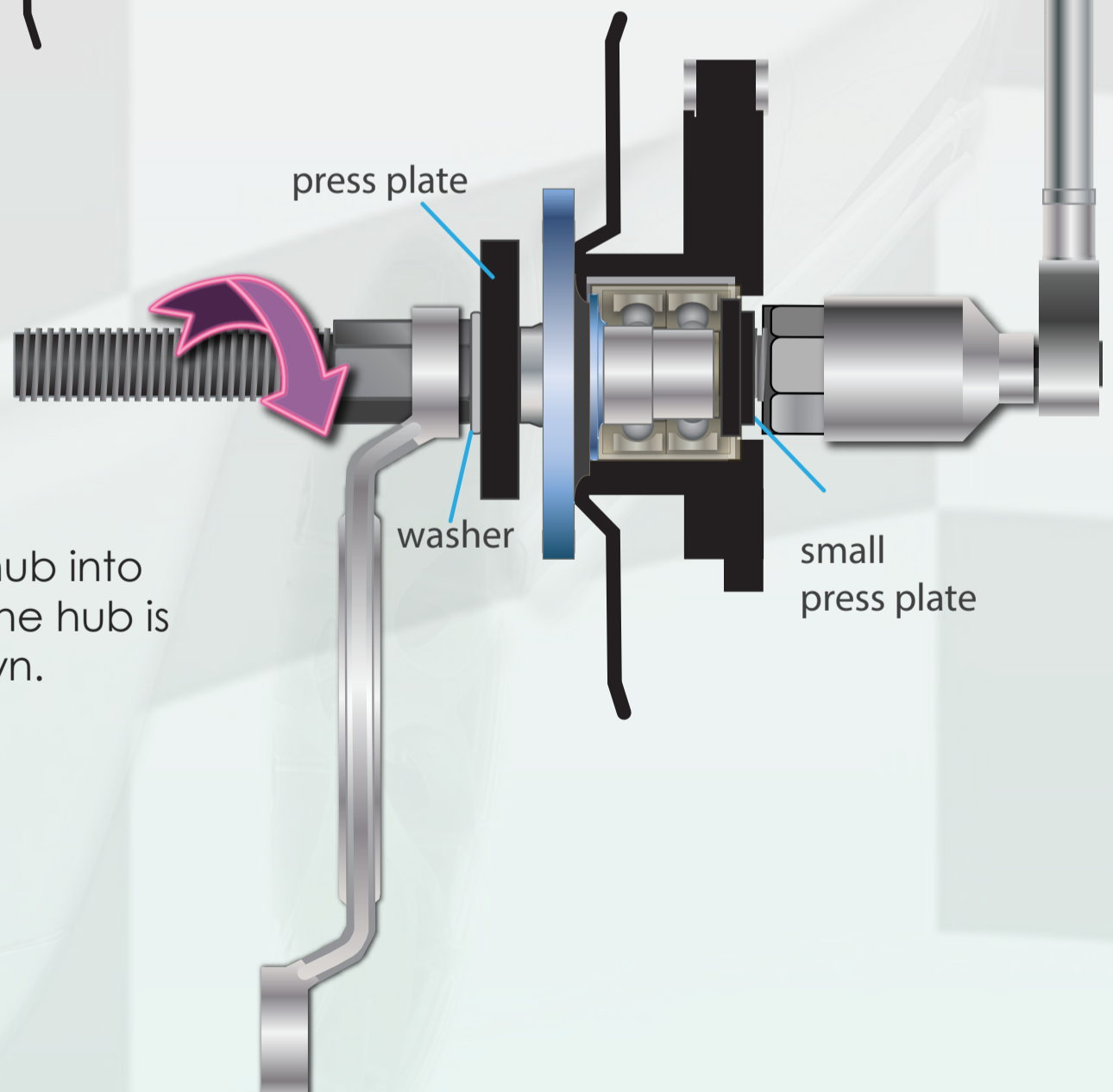
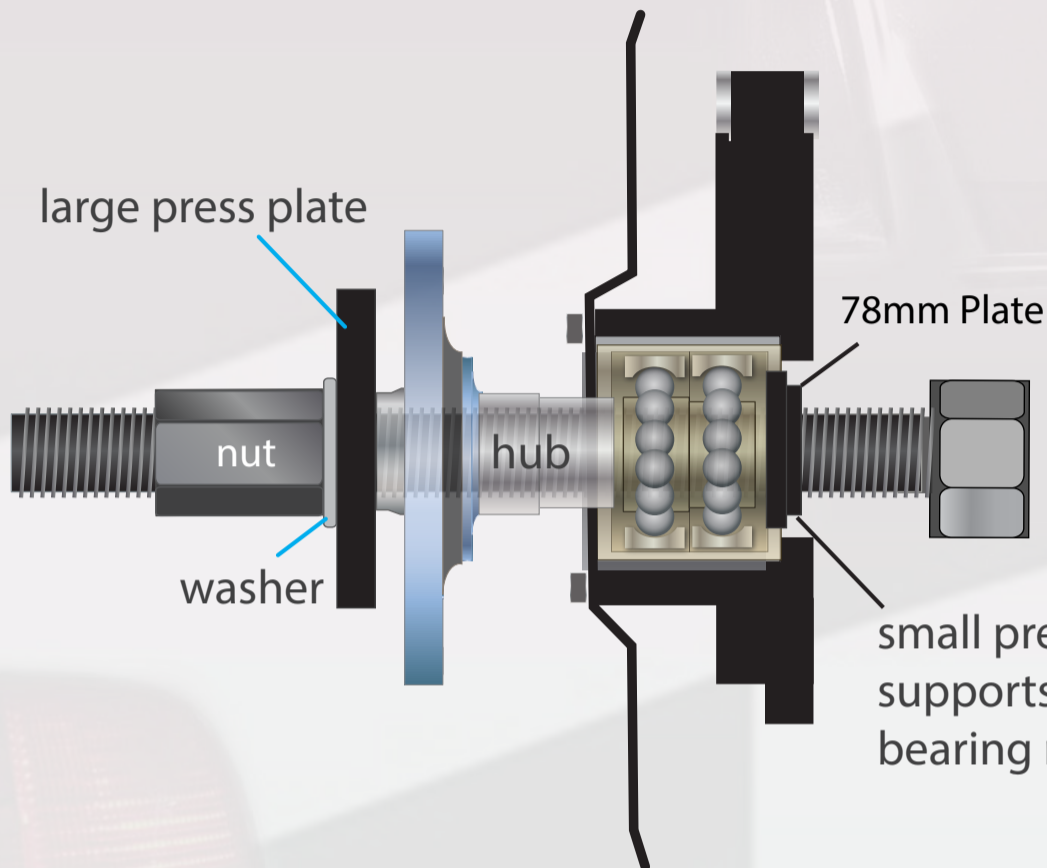

Turn the nut to pull the hub into the bearing bore, until the hub is pressed all the way down.

Final Reassembly

- 1) Reinstall the axle. Slide the splined end of the axle stub into the drive hub. Bolt the inner constant velocity joint to the drive axle hub. Replace and tighten all axle joint bolts, reinstall lower control arm (refer to tightening specifications on 3rd page.)
- 2) Reinstall the wheel speed sensor
- 3) Reinstall the rotor shield.
- 4) Reinstall the brake rotor and caliper.
- 5) Install a new shoulder (axle) bolt and torque to specifications.
- 6) Install the road wheel/tire and torque the wheel bolts to specifications.

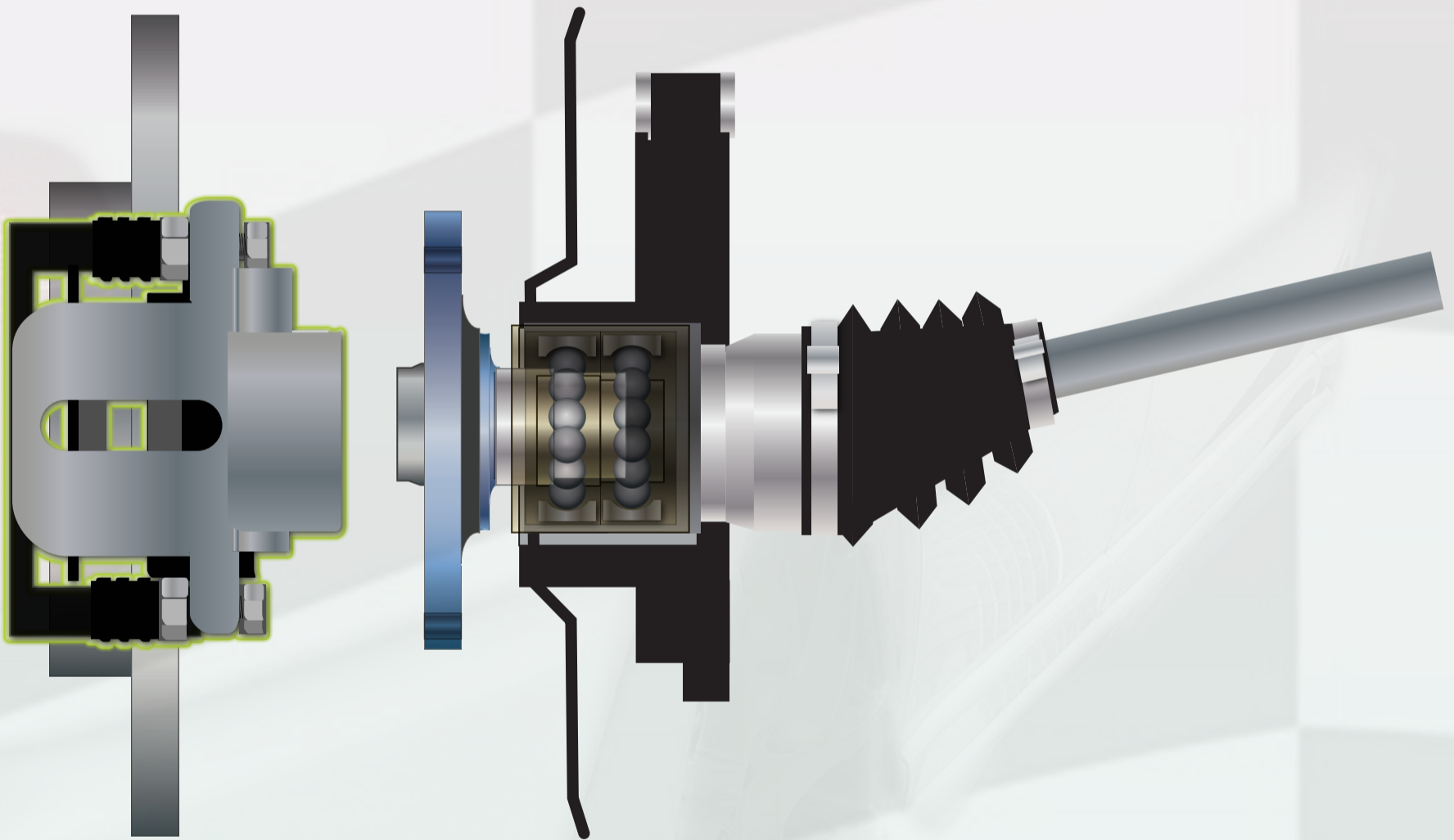

Thanks!

Thank you for purchasing the Schwaben Audi Quattro Rear Wheel Bearing Service Kit. We appreciate your business, and hope this installation guide has been helpful.

