

ECS TUNING

Installation Instructions



Table of Contents

- 2 - What Kit Do You Need?
- 3 - Old and New Blocks
- 4 - Installing the Bleeder Block
- 5 - Bleeding the System
- 6 - Reaching the Block on MKIV
- 8 - Reaching the Block on MKV
- 9 - Reaching the Block on MKVI

Part Number [ES2586656](#)
[ES2608027](#)

6-Speed Clutch Bleeder Block Installation

This tutorial is provided as a courtesy by ECS Tuning.

Proper service and repair procedures are vital to the safe, reliable operation of all motor vehicles as well as the personal safety of those performing the repairs. Standard safety procedures and precautions (including use of safety goggles and proper tools and equipment) should be followed at all times to eliminate the possibility of personal injury or improper service which could damage the vehicle or compromise its safety.

Although this material has been prepared with the intent to provide reliable information, no warranty (express or implied) is made as to its accuracy or completeness. Neither is any liability assumed for loss or damage resulting from reliance on this material. SPECIFICALLY, NO WARRANTY OF MERCHANTABILITY, FITNESS FOR A PARTICULAR PURPOSE OR ANY OTHER WARRANTY IS MADE OR TO BE IMPLIED WITH RESPECT TO THIS MATERIAL. In no event will ECS Tuning, Incorporated or its affiliates be liable for any damages, direct or indirect, consequential or compensatory, arising out of the use of this material.

VW/Audi 6-Speed Clutch Bleeder Kits

ES2586656 and ES2608027



Which Kit Do I Need?

The ECS Tuning 6-speed Clutch Bleeder Block is available in two kits to fit a wide range of VW-Audi vehicles. The two kits are identical except for a difference in the fluid seal used to connect the hose from the clutch master cylinder to the bleeder block.

The illustration on this page shows the difference between the master cylinder hose configurations and seals. The o-ring seal used at the connection between the bleeder block and concentric clutch slave cylinder is identical in both kits, for all models listed below.

SPECIAL NOTE: Be sure to remove the old seals and install the new seals included in the kits, as shown. For kits containing a grommet seal as opposed to an o-ring for the master cylinder inlet hose, please carefully observe the installation procedure outlined on Page 5 to ensure proper fitment.

Bleed the system to remove all air. The bleeder valve contains a one-way check valve, so no special bleeding equipment is needed.

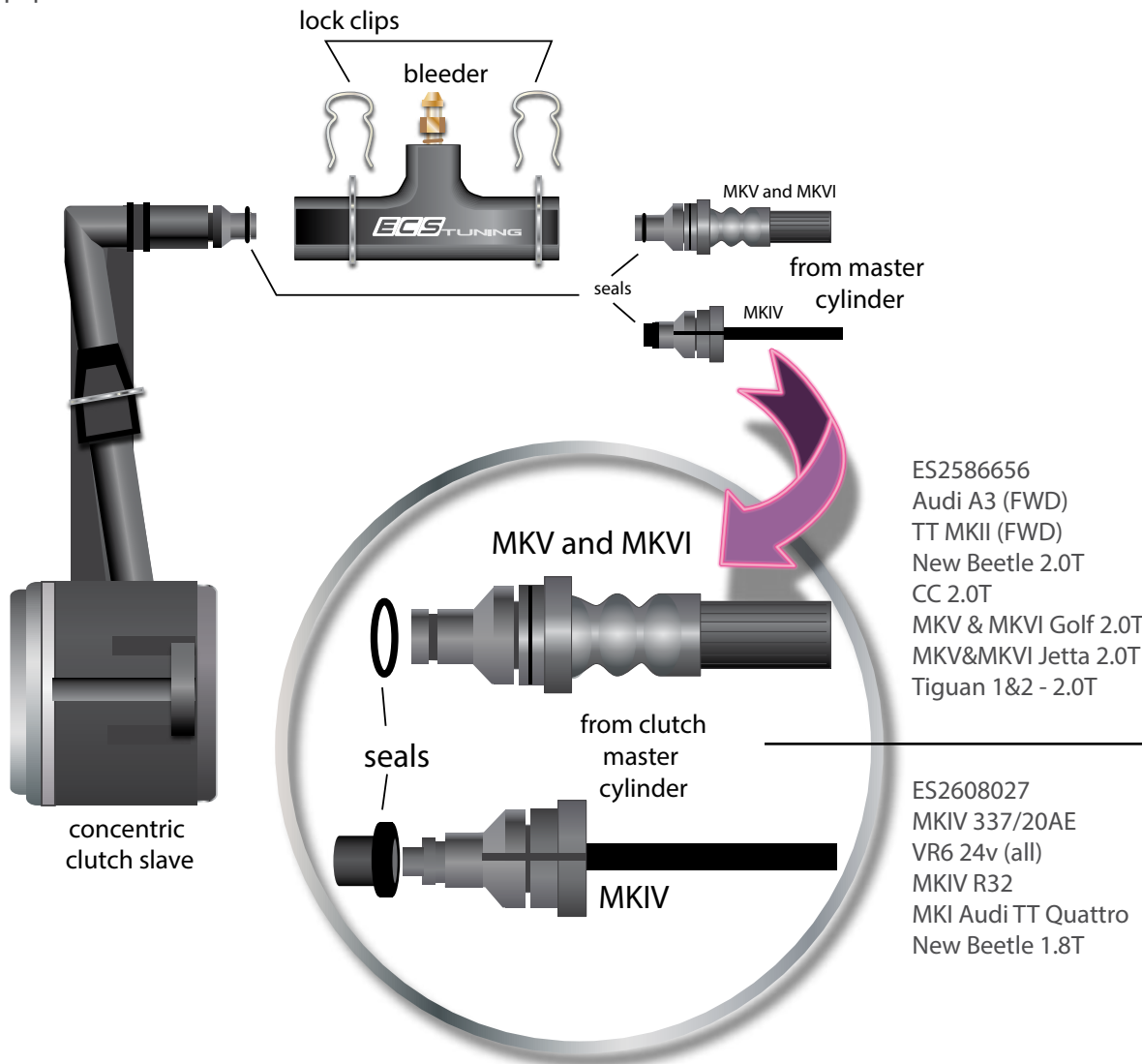

VW-Audi 6-Speed Clutch Bleeder Block Installation



ES2586656 and ES2608027

Old and New Blocks



The ECS Tuning 6-Speed Clutch Bleeder Block has features not found in the original factory-installed bleeder block. Made of black anodized aluminum with a steel bleeder screw, the ECS Tuning bleeder block will not flex or expand, and is less apt to leak.

The fluid passage inside the ECS Tuning bleeder block is larger, for less fluid restriction and faster operation of the concentric clutch slave cylinder.

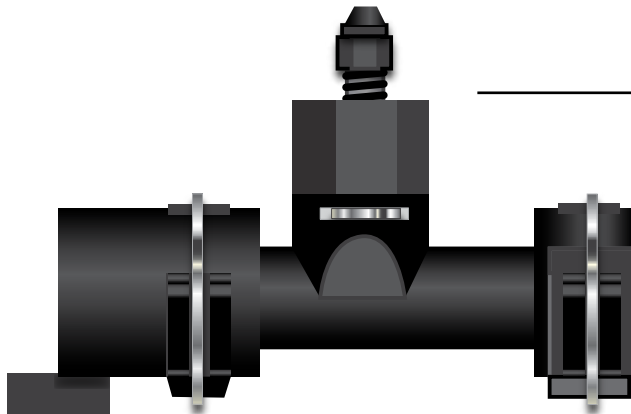
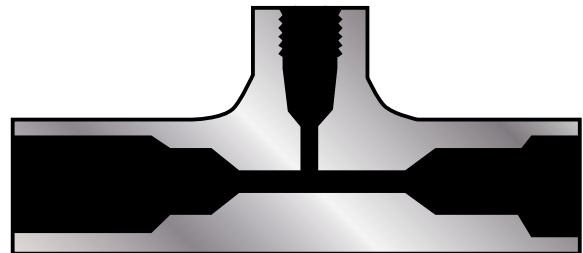

By comparison, the factory original bleeder block body is plastic, with a metal bleeder insert. This design is more apt to distort from pressure and heat, and is also more prone to fluid leakage at the bleeder screw insert seal.

The internal fluid passage is narrower, creating a fluid restriction that delays slave cylinder response.

VW-Audi 6-Speed Clutch Bleeder Block Installation



Installing the New Bleeder Block

Installing the bleeder block is the same on MKIV, MKV, and MKVI vehicles. General procedures outlined below apply to all three models.

Remove the Original Bleeder Block

- 1) Using a pick or small screwdriver, pull up the two metal spring clips on the original plastic bleeder block.
- 2) Slide the supply hose from the clutch master cylinder out of the bleeder block.
- 3) Slide the bleeder block off the slave cylinder tube. Discard the old bleeder block.
- 4) Remove the old o-rings, or o-ring and seal, depending on which hose style is used.

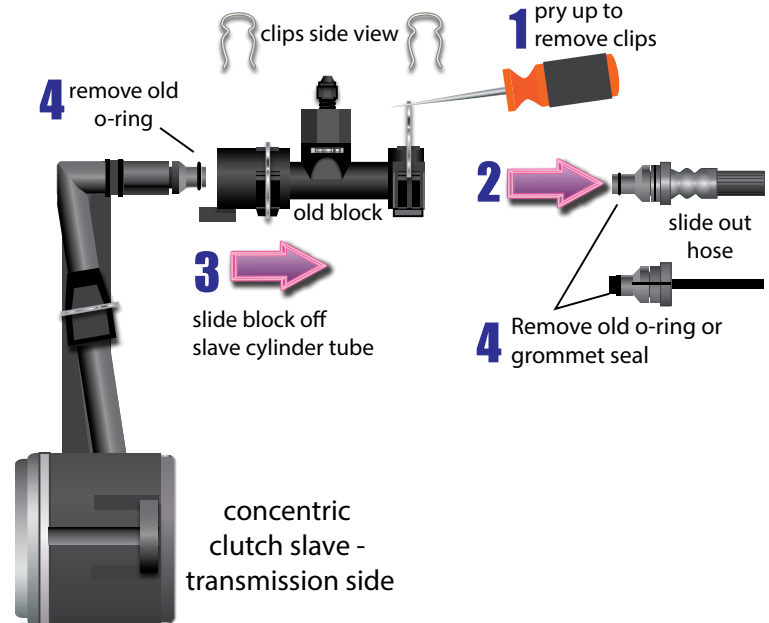

Install the ECS Bleeder Block

- 1) Install the new o-rings (or o-ring and grommet seal) on the slave cylinder tube and inlet hose. Install a new o-ring on the slave cylinder tube.

Note: For [ES2608027](#) please refer to page 5 for important sealing instructions.

- 2) Slide the "long end" of the new bleeder block onto the slave cylinder tube. Push the new retainer clip into the grooves in the block until it snaps in place.
- 3) Slide the hose from the clutch master cylinder into the other end of the block. Insert the remaining retainer clip.

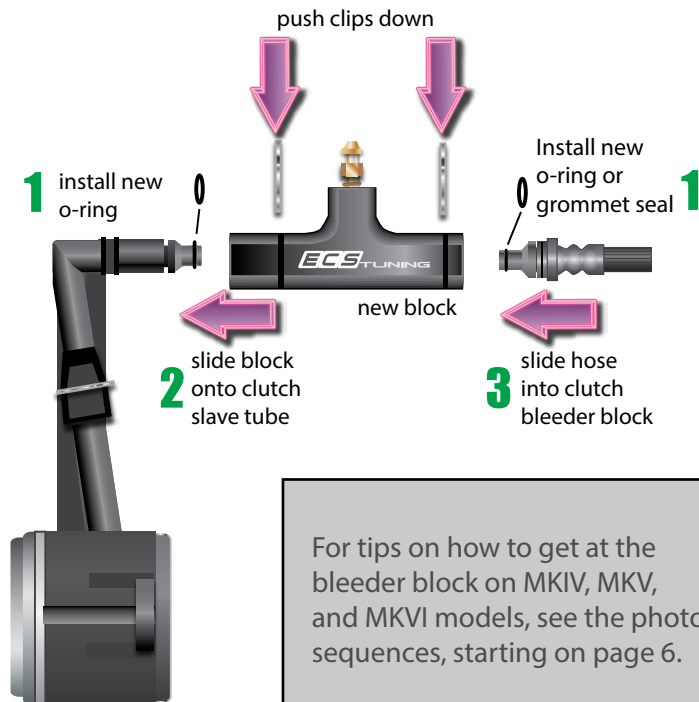

For tips on how to get at the bleeder block on MKIV, MKV, and MKVI models, see the photo sequences, starting on page 6.

VW-Audi 6-Speed Clutch Bleeder Block Installation



Grommet Seal Installation Procedure



1. Lubricate the new grommet seal with brake fluid.



2. Lubricate the inlet hose at the site of the grommet seal.



3. Position the seal as shown and press down firmly until the grommet seal fully seats onto the inlet hose.



4. The fully seated inlet hose seal is shown above.



5. Install the inlet hose from the master cylinder into the the new ECS bleeder block as shown.

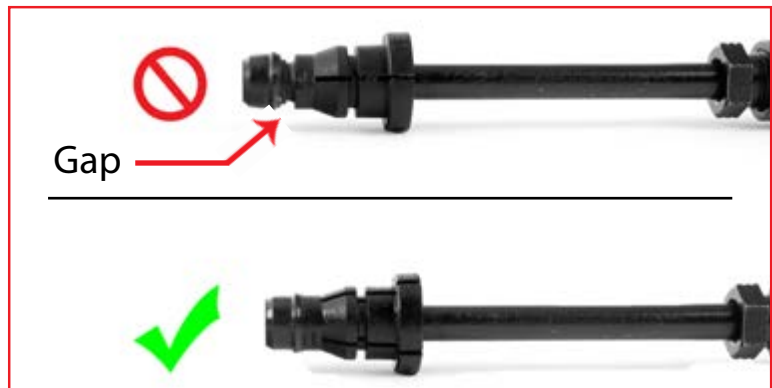

The top image shows the grommet seal improperly installed. The bottom image shows the correct installation.

VW-Audi 6-Speed Clutch Bleeder Block Installation



ES2586656 and ES2608027

Bleeding the System

To make bleeding the clutch hydraulic system an easy one-man job, your ECS Tuning Bleeder Block has a one-way valve built into the bleeder screw. There's no need for power or vacuum bleeding equipment.

Here's the procedure:

- Remove the rubber bleeder screw cap.
- Using an 8mm wrench, crack the bleeder screw 1/4 turn (no more).
- Attach the clear flexible hose from a bleeder catch bottle to the bleeder screw.
- Inside the car, push the clutch pedal to the floor by hand, then pull it up again slowly. Do this several times until the brake fluid runs clear and bubble-free through the bleeder hose.
- Close the bleeder. Reinstall the rubber bleeder cap.
- Check clutch operation.

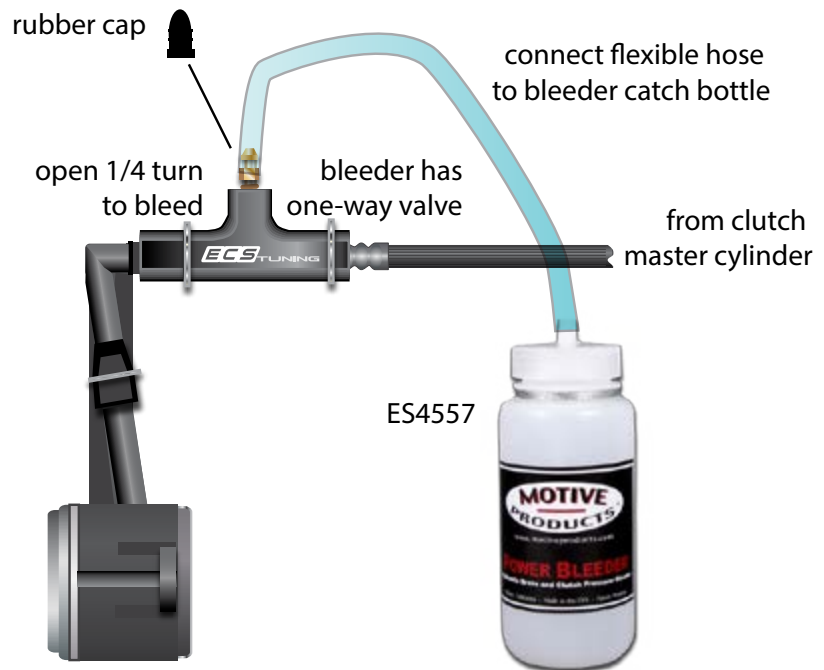

Add fresh brake fluid to the master cylinder to replace the fluid lost during bleeding.

The rear section of the reservoir supplies fluid to the clutch master cylinder. It is separated from the front (brake) section by a divider.

Slightly overfill the front section until it spills over into the rear section.

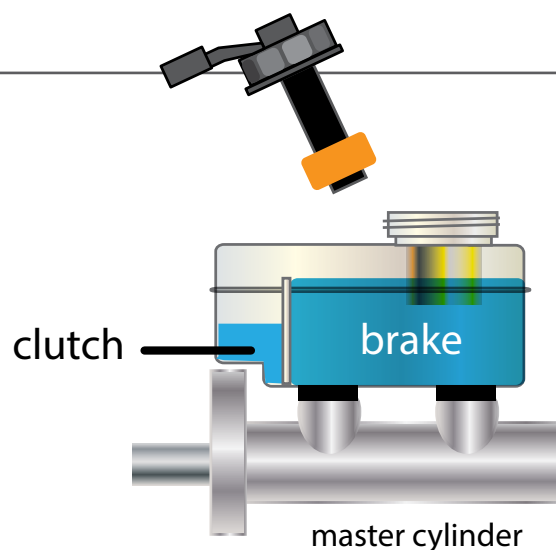

VW-Audi 6-Speed Clutch Bleeder Block Installation



MKIV Reaching the Clutch Bleeder Block

You're wearing your protective goggles and long sleeved clothing, right?

Remove the Battery Cover

Pull up on the plastic battery cover to remove it.



Unbolt and Disconnect the Battery Terminals

Loosen the terminal ends and remove them from the battery.

Lift the power distribution box off the top of the battery.

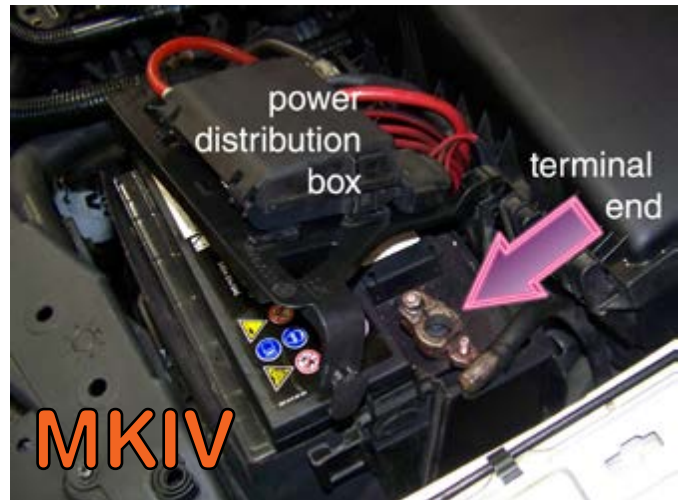

Unbolt the Battery Holddown

Using a long extension and a 13mm ratchet, loosen and remove the battery hold down bolt and bracket.

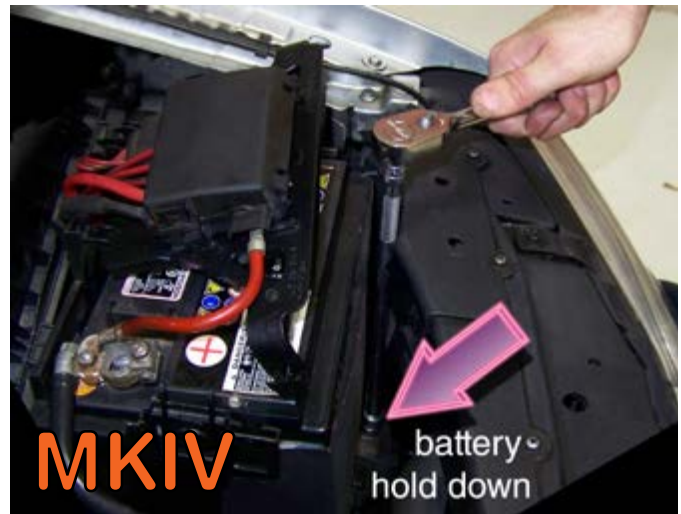

VW-Audi 6-Speed Clutch Bleeder Block Installation



MKIV Reaching the Clutch Bleeder Block

Remove the Battery

Wearing gloves to protect your skin from battery acid, lift the battery out of the battery tray and set it aside, out of the way.



Remove the Battery Tray

Using a ratchet, extension, and 10mm socket, remove the four bolts at the base of the battery tray, plus the air filter attachment bolt (arrows).

Lift out the battery tray.



Replace Bleeder Block

With the battery tray removed, the old bleeder block is clearly visible (arrow), located between the wiring harness connector and the transmission pivot arm.

Now you can use the instructions on pages 4 and 5 of this pdf to install and bleed your new ECS Clutch Bleeder Block.

Replace the battery tray, battery, and power distribution box in reverse order of removal to complete the MKIV installation.

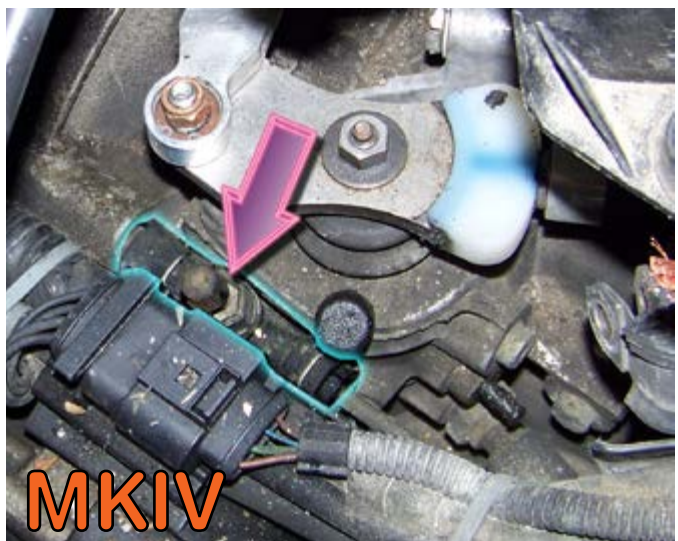

VW-Audi 6-Speed Clutch Bleeder Block Installation



MKV Reaching the Clutch Bleeder Block

Disconnect the Air Filter Inlet Hose
Using pliers, remove the large spring clamp at the air inlet hose connection on the air filter housing.



Remove the Air Inlet Scoop
Using a T20 Torx driver, reach in at the rear of the air inlet scoop and remove the two attachment screws.

(Our arrows point you in the right general direction.)

When the screws are removed, lift the air scoop out of the car.



Install the New Bleeder Block
With the air hose removed, the old bleeder block is exposed (arrow), located between the starter motor and shift relay pivot arm.

Now you can install your new ECS Tuning Clutch Bleeder Block using the steps outlined on pages 4 and 5 of this pdf.

Then reinstall the air intake hose.



VW-Audi 6-Speed Clutch Bleeder Block Installation



MKVI Reaching the Clutch Bleeder Block

Remove the Air Intake Components

To gain access to the clutch bleeder block requires removal of the air inlet scoop and air filter box.

The battery, identified for reference, does NOT need to be removed in the MKVI.



Remove the Air Intake Scoop

Reaching from the rear of the air intake scoop with a T25 Torx® driver, remove the two air scoop attachment screws.



Remove the Air Intake Scoop

After removing the screws, grab the air scoop and remove it.



VW-Audi 6-Speed Clutch Bleeder Block Installation



MKVI Reaching the Clutch Bleeder Block

Remove the Air Duct

Remove the u-shaped air horn that connects the air scoop to the air filter box.



Disconnect the MAF

Press the release clip on the side of the electrical connector and unplug the mass air flow sensor.



Unbolt the Air Box

Using a long 5mm hex driver, remove the air filter box retainer bolt.



VW-Audi 6-Speed Clutch Bleeder Block Installation



MKVI Reaching the Clutch Bleeder Block

Remove the Spring Clamp

Using pliers or a spring clamp tool, remove the large clamp securing the air intake duct to the throttle.



Remove the Air Box

The air box has two rubber grommets at its base that push-fit in plastic mounting pins.

Pull the box upward to release the pins, and set it aside.



Install the Bleeder Block

With the air box removed, the bleeder block is clearly exposed and accessible.

Use the general instructions on pages 4 and 5 of this pdf to install your new bleeder block, then reverse the removal steps to reinstall the air box and intake duct work.



VW-Audi 6-Speed Clutch Bleeder Block Installation



Thanks for purchasing the
ECS Tuning
6-Speed Clutch Bleeder Block

We appreciate your business,
and hope this tutorial has
been helpful.



visit us at www.ecstuning.com