

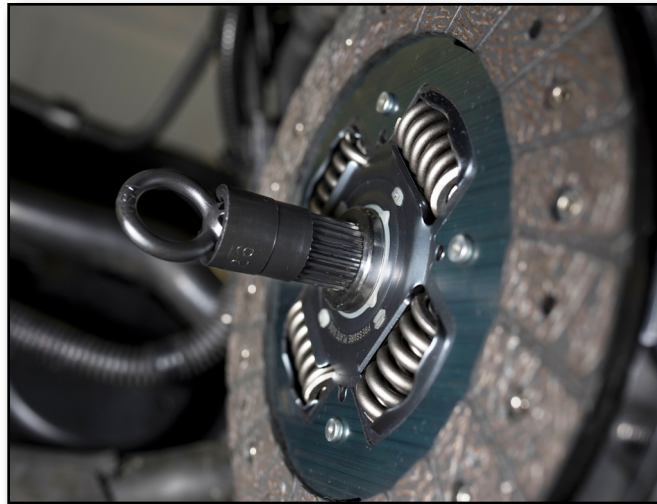

VW/Audi 2.0T Gen3/Evo4 TSI 6-Speed  
ECS Clutch & Lightweight Flywheel Kit  
Installation Instructions - [Click HERE to Shop](#)

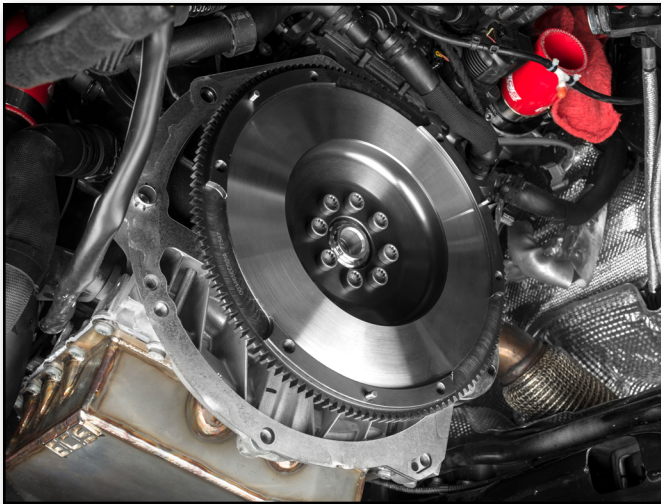

**Skill Level**  
**3 - Advanced**  
**Advanced Skills &  
Experience Required**

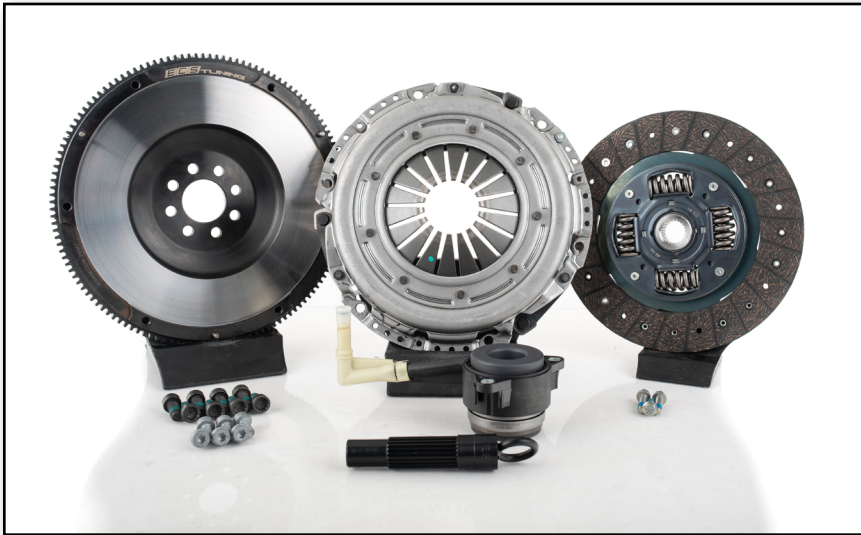

Proper service and repair procedures are vital to the safe, reliable operation of all motor vehicles as well as the personal safety of those performing the repairs. Standard safety procedures and precautions (including use of safety goggles and proper tools and equipment) should be followed at all times to eliminate the possibility of personal injury or improper service which could damage the vehicle or compromise its safety.

## INTRODUCTION

# VW/Audi 2.0T Gen3/Evo4 TSI ECS Clutch & Lightweight Flywheel Kit

**ECS clutch & lightweight flywheel kits offer these impressive technical features and performance benefits:**

- Heat treated billet chromoly 4140 steel flywheel
- Black Zinc plating for corrosion resistance
- Precision balanced
- SFI 1.1 tested and approved
- Designed in-house by ECS Tuning engineers
- Improved throttle response and acceleration
- Kits include a new pressure plate, clutch disc, throwout bearing/slave cylinder, alignment tool, flywheel bolts, pressure plate bolts, and slave cylinder bolts

Installing an ECS clutch & lightweight flywheel kit is a weekend project that will reward you with the superior performance and durability of the finest products available. It would be best to plan on two full days to complete this installation. If you do not have previous experience it may take longer, but following these instructions closely will help you achieve a smooth, trouble-free installation. Plan your time accordingly based on your experience level. Before you begin, read and familiarize yourself with these instructions and make sure you have all the required tools on hand.

Thank you for purchasing our clutch & lightweight flywheel kit, we appreciate your business!

## TABLE OF CONTENTS

Kit Contents.....	<a href="#">pg.4</a>
Required Tools and Equipment.....	<a href="#">pg.5</a>
Shop Supplies and Materials.....	<a href="#">pg.6</a>
Installation and Safety Information.....	<a href="#">pg.7</a>
Transmission Bolt Template.....	<a href="#">pg.8</a>
Transmission Component Locations.....	<a href="#">pg.9</a>
Removing the Transmission.....	<a href="#">pg.11</a>
Removing the Original Flywheel and Clutch.....	<a href="#">pg.32</a>
Cleaning the Engine Block.....	<a href="#">pg.33</a>
Installing the New Flywheel and Clutch.....	<a href="#">pg.34</a>
Preparing the Transmission for Installation.....	<a href="#">pg.39</a>
Reinstalling the Transmission.....	<a href="#">pg.41</a>
Clutch Break-In Period.....	<a href="#">pg.44</a>
Clutch Hydraulic System: Manual Bleeding.....	<a href="#">pg.45</a>
Clutch Hydraulic System: Pressure Bleeding.....	<a href="#">pg.46</a>
Torquing Tips.....	<a href="#">pg.47</a>
Torque Specifications.....	<a href="#">pg.48</a>

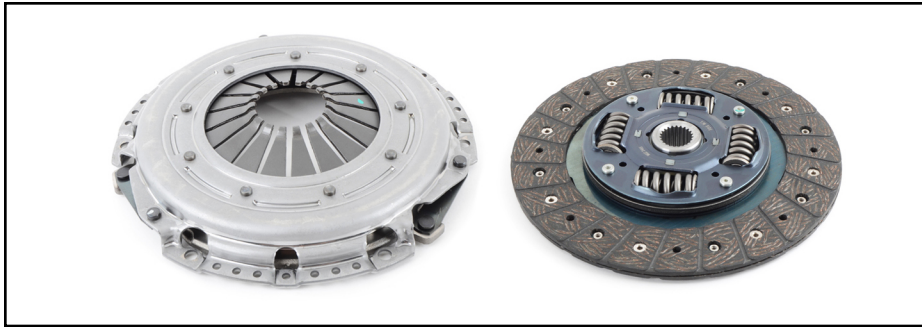

**CAUTION:** The most important tool for this job is patience. Please read each step thoroughly and do not omit any of them. Obtaining the proper clearance for transmission removal is very important and many of these steps are intended for that reason. Be sure to have a friend help you during transmission removal, the transmission is very heavy and difficult to maneuver.

**KIT CONTENTS**

ECS Clutch Assembly (Pressure Plate &amp; Clutch Disc)



Throwout Bearing/Slave Cylinder Assembly



ECS Single Mass Lightweight Steel Flywheel (19lbs)



Clutch Alignment Tool



Flywheel Bolts (8)



Pressure Plate Bolts (6)



Throwout Bearing Bolts (3)

## REQUIRED TOOLS

Note: The tools required for each step will be listed by the step number throughout these instructions.

### Standard Automotive Tools

- **Protecta-Sockets (for lug nuts)** ..... [ES#2221243](#)
- **3/8" Drive Ratchet** ..... [ES#2765902](#)
- **3/8" Drive Torque Wrench** ..... [ES#2221245](#)
- **3/8" Drive Deep and Shallow Sockets** ..... [ES#2763772](#)
- **3/8" Drive Extensions** ..... [ES#2804822](#)
- **Hydraulic Floor Jack** ..... [ES#2834951](#)
- **Torx Drivers and Sockets** ..... [ES#11417/8](#)
- **1/2" Drive Deep and Shallow Sockets** ..... [ES#2839106](#)
- **1/2" Drive Ratchet**
- **1/2" Drive Extensions**
- **1/2" Drive Torque Wrench** ..... [ES#2221244](#)
- **1/2" Drive Breaker Bar** ..... [ES#2776653](#)
- **Wheel Hanger** ..... [ES#2678092](#)
- **Oil Drain Pan** ..... [ES#2748892](#)
- **Hook and Pick Tool Set** ..... [ES#2778980](#)

### Required For This Install

- **1/4" Drive Ratchet** ..... [ES#2823235](#)
- **1/4" Drive Deep and Shallow Sockets** ..... [ES#2823235](#)
- **1/4" Drive Extensions** ..... [ES#2823235](#)
- **Plier and Cutter Set** ..... [ES#2804496](#)
- **Flat and Phillips Screwdrivers** ..... [ES#2225921](#)
- **Jack Stands** ..... [ES#2763355](#)
- Ball Pein Hammers
- Pry Bar Set ..... [ES#1899378](#)
- Electric/Cordless Drill
- Wire Strippers/Crimpers
- Drill Bits
- Punch and Chisel Set
- **Hex Bit (Allen) Wrenches and Sockets** ..... [ES#11420](#)
- Thread Repair Tools ..... [ES#1306824](#)
- **Open/Boxed End Wrench Set** ..... [ES#2765907](#)

### Available On Our Website

### Specialty Tools

- **Engine Support Bar** ..... [ES#2804773](#)
- **Wheel Hanger** ..... [ES#2678092](#)
- **Triple Square Socket Set** ..... [ES#1910125](#)
- **Locking Spring Clamp Pliers** ..... [ES#2702616](#)

- **VAG Connector Release Tool** ..... [ES#2628676](#)
- **Brake Fluid Catch Bottle** ..... [ES#4557](#)
- **Transmission Jack**
- **1/2" Drive Impact Wrench**

## SHOP SUPPLIES AND MATERIALS

**Standard Shop Supply Recommendations:** We recommend that you have a standard inventory of automotive shop supplies before beginning this or any automotive repair procedure. The following list outlines the basic shop supplies that we like to keep on hand. Shop supplies with a hyperlink are available on our website.

- Hand Cleaner/Degreaser - [Click Here](#)
- Pig Mats - for protecting your garage floor and work area from spills and stains - [Click Here](#)
- Spray detailer - for rapid cleaning of anything that comes into contact with your paint such as brake fluid - [Click Here](#)
- Micro Fiber Towels - for cleaning the paint on your car - [Click Here](#)
- Latex Gloves - for the extra oily and dirty jobs - [Click Here](#)
- Medium and High Strength Loctite Thread lock compound - to prevent bolts from backing out - [Click Here](#)
- Anti-Seize Compound - to prevent seizing, galling, and corrosion of fasteners - [Click Here](#)
- Aerosol Brake/Parts Cleaner - for cleaning and degreasing parts
- Shop Rags - used for wiping hands, tools, and parts
- Penetrating oil - for helping to free rusted or stuck bolts and nuts
- Mechanics wire - for securing components out of the way
- Silicone spray lube - for rubber components such as exhaust hangers
- Paint Marker - for marking installation positions or bolts during a torquing sequence
- Plastic Wire Ties/Zip Ties - for routing and securing wiring harnesses or vacuum hoses
- Electrical tape - for wrapping wiring harnesses or temporary securing of small components

## INSTALLATION NOTES

- **RH** refers to the *passenger side* of the vehicle.
- **LH** refers to the *driver side* of the vehicle.
- Always use the proper torque specifications.
- If applicable to this installation, torque specifications will be listed throughout the document and at the end as well.
- Please read all of these instructions and familiarize yourself with the complete process **BEFORE** you begin.

## GENERAL PREPARATION AND SAFETY INFORMATION

ECS Tuning cares about your health and safety, please read the following safety information. This information pertains to automotive service in general, and while it may not pertain to every job you do, please remember and share these important safety tips.

- Park your car in a safe, well lit, level area.
- Shut the engine off and remove the key from the ignition switch.
- Make sure any remote start devices are properly disabled.
- **ALWAYS** wear safety glasses.
- Make sure the parking brake is applied until the vehicle is safely lifted and supported.
- Whether lifting a vehicle using an automotive lift or a hydraulic jack, be sure and utilize the factory specified lift points.
- Lifting a vehicle in an incorrect location can cause damage to the suspension/running gear.
- **ALWAYS** support the vehicle with jack stands.
- **ALWAYS** read and follow all safety information and warnings for the equipment you are using.



**NEVER** get underneath a vehicle that is supported only by a jack, and **ALWAYS** make sure that the vehicle is securely supported on jack stands.

# TRANSMISSION BOLT TEMPLATE

Print this page and tape it to a cardboard box. Punch holes at each bolt location and use it to store the bolts as you remove them. This will keep them perfectly organized for reassembly.

1. Upper Starter Bolt - M12x165mm
2. Lower Starter Bolt - M12x165mm
3. Upper Bell Housing Bolt - M12x55mm w/short end stud
4. Upper Bell Housing Bolt - M12x55mm w/long end stud
5. Rear Bell Housing Bolt - M12x70mm
6. Lower Bell Housing Bolt - M10x50mm
7. Lower Bell Housing Bolt - M10x50mm
8. Front Bell Housing Bolt - M10x105mm
9. Exhaust Downpipe Bracket Bolts
10. Pendulum Support Bolts
11. Transmission Mount Bolts
12. Battery Tray Bolts
13. Shifter Cable Bracket Bolts and Nut
14. CV Heat Shield Bolts
15. Transmission Bracket Bolts

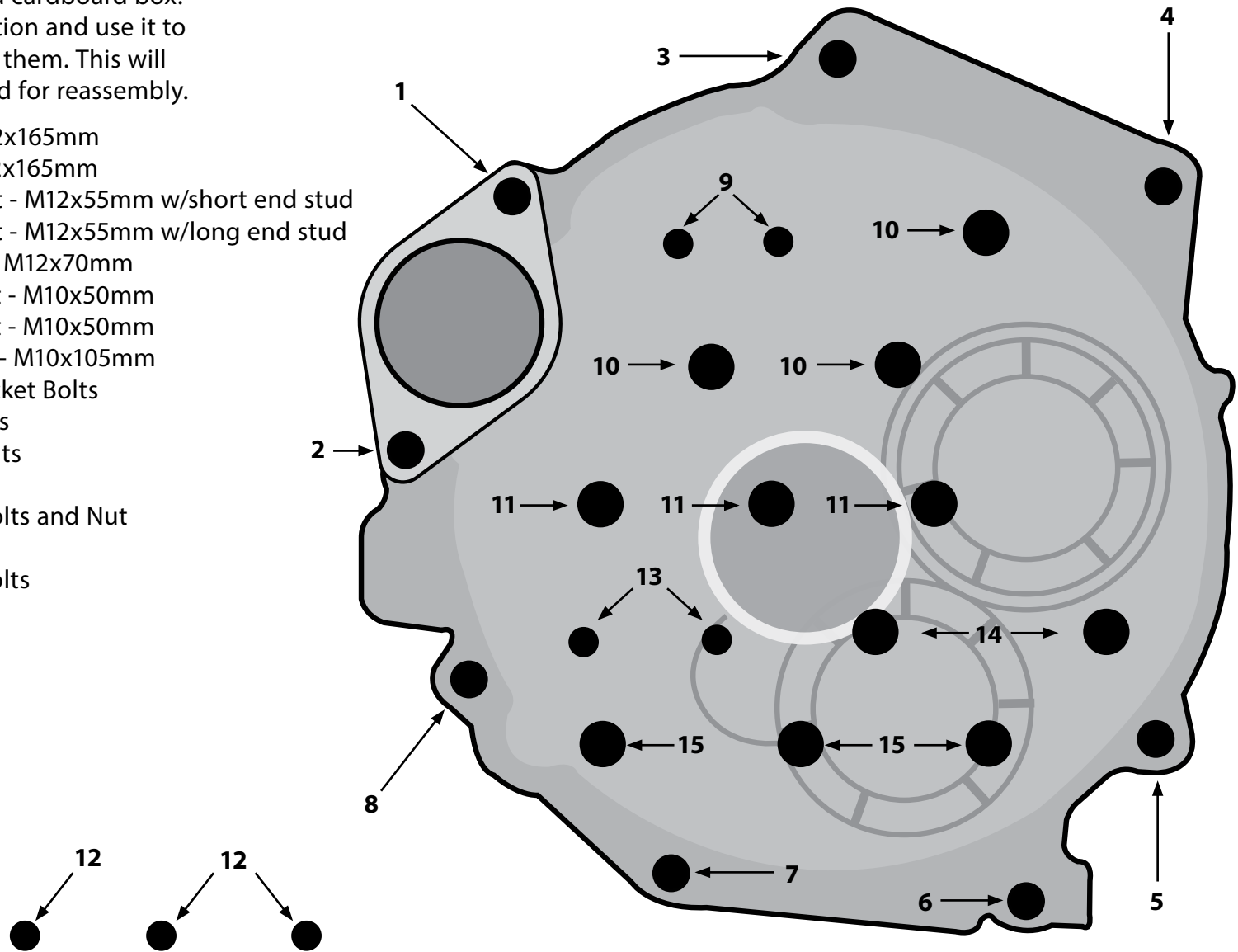



## TRANSMISSION COMPONENT LOCATIONS

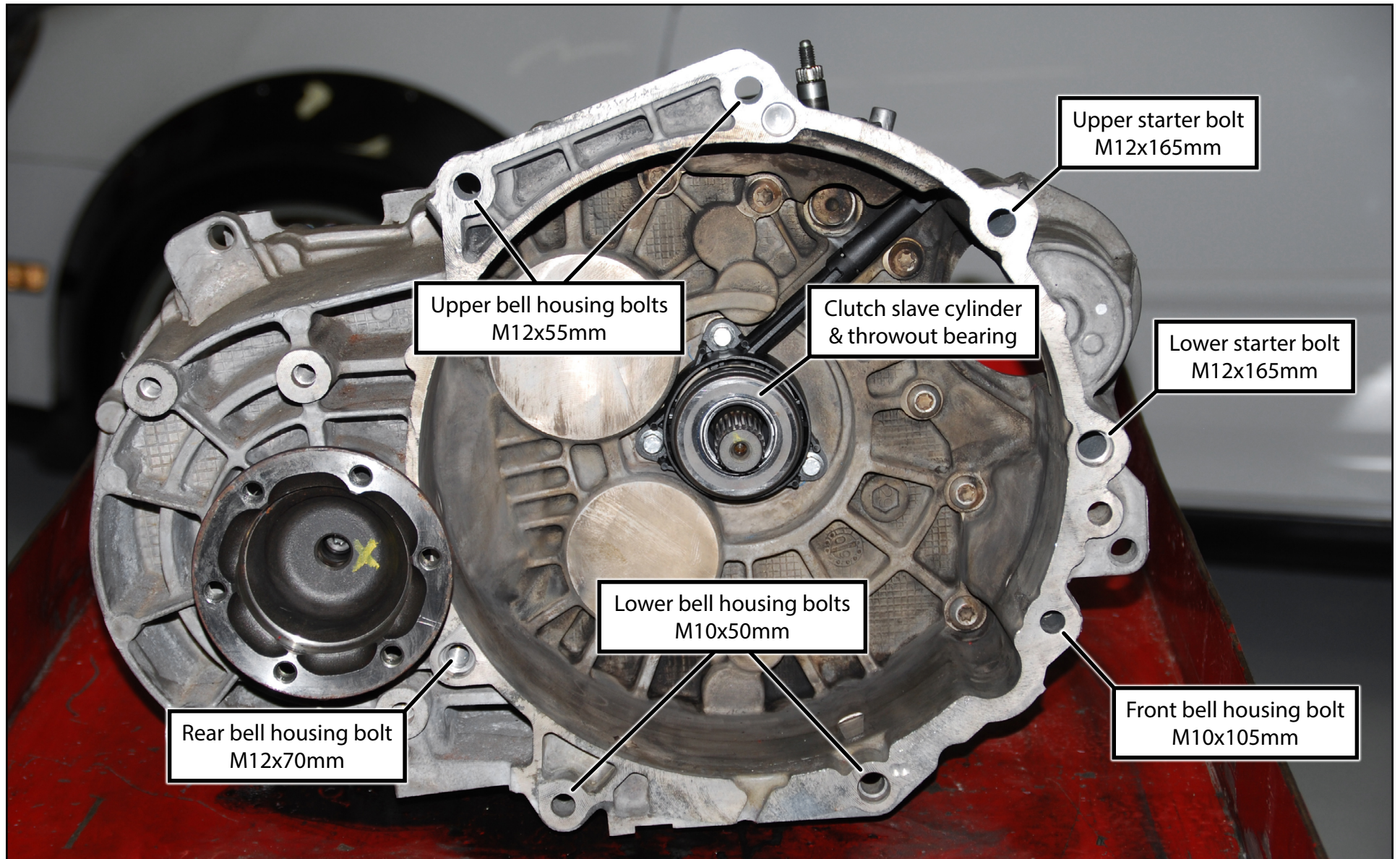

## TRANSMISSION COMPONENT LOCATIONS

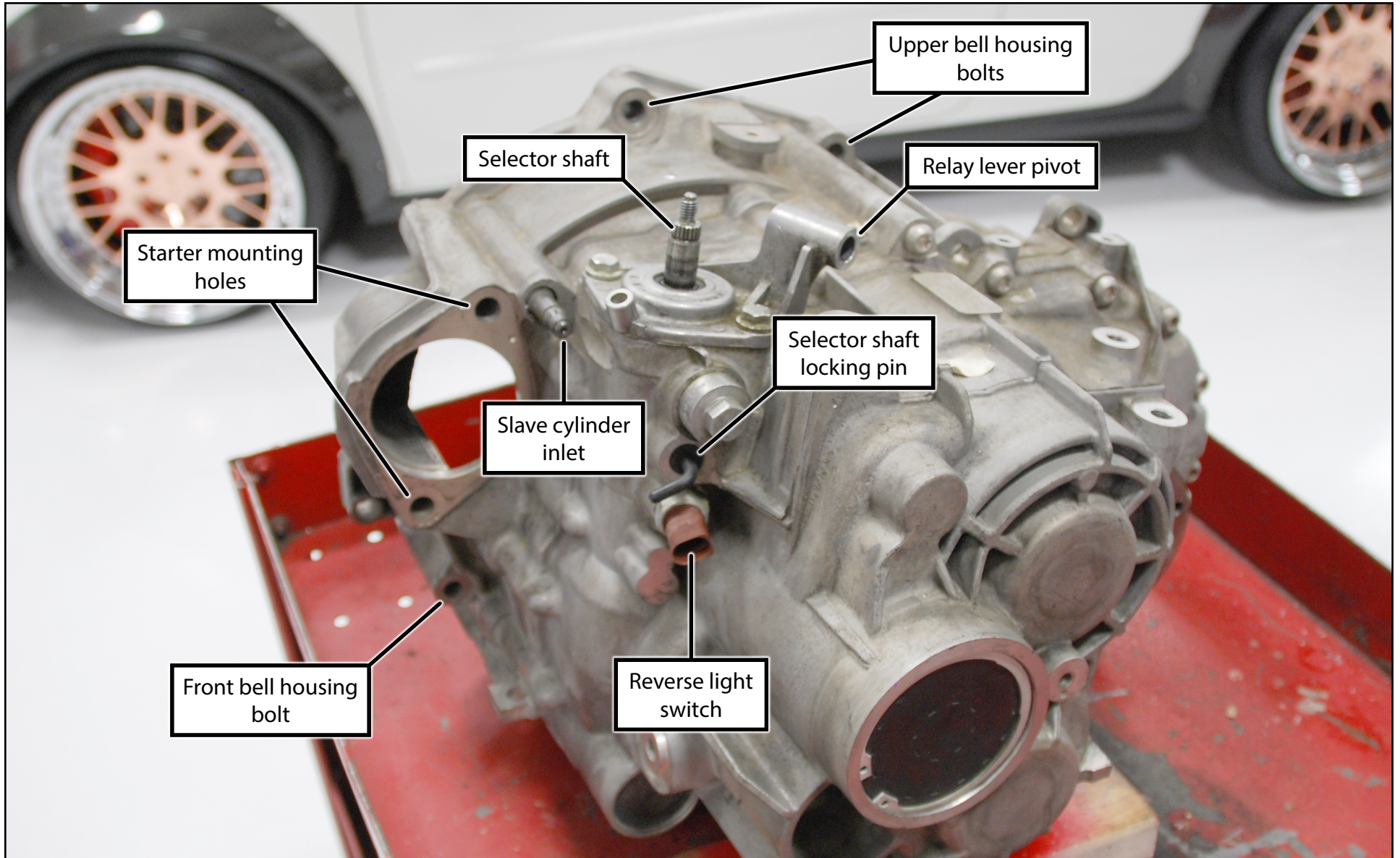

## REMOVING THE TRANSMISSION

### Step 1:

Let's begin under the hood. Remove the intake system, battery and battery tray.



**CAUTION:** To reduce the risk of fire, explosion, or personal injury, **ALWAYS** disconnect the battery by removing the negative battery terminal first.



If you have decided to use our bolt storage template, store the battery tray bolts in location #12.

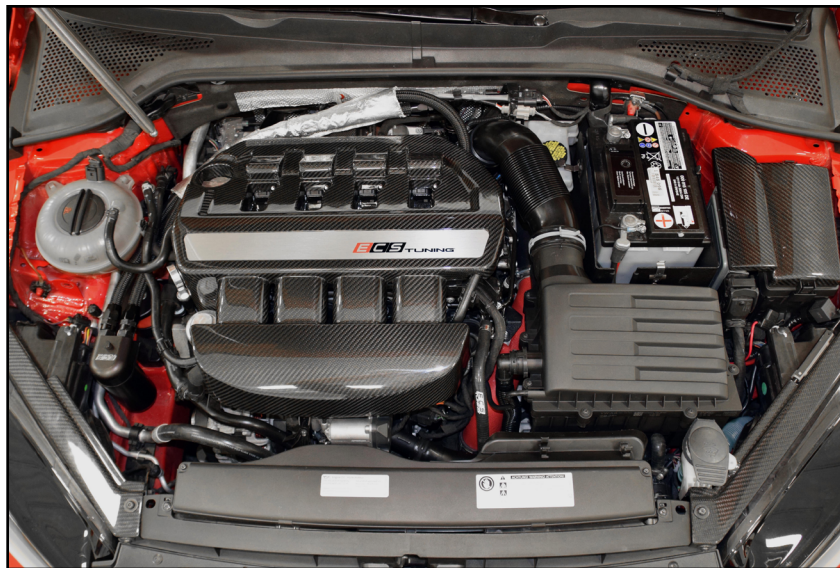

### Step 2:

With the intake system, battery and battery tray removed, this is what we will be left with. Now let's get to it!

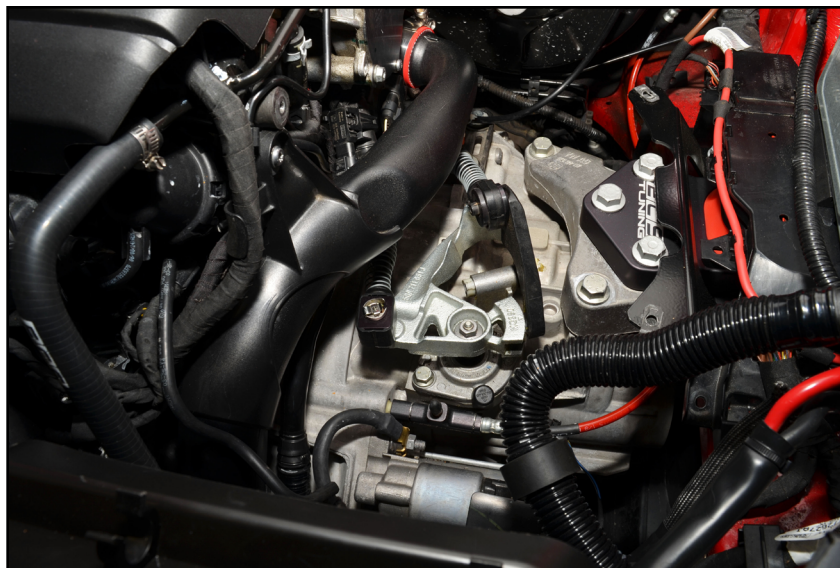

## REMOVING THE TRANSMISSION

### Step 3:

Release the connector on the starter solenoid by pulling the connector lock out, then squeezing the end of the connector and pulling it off. The reverse light switch connector does not have a lock out built in, so it can be released simply by squeezing the end of the connector and pulling it off.

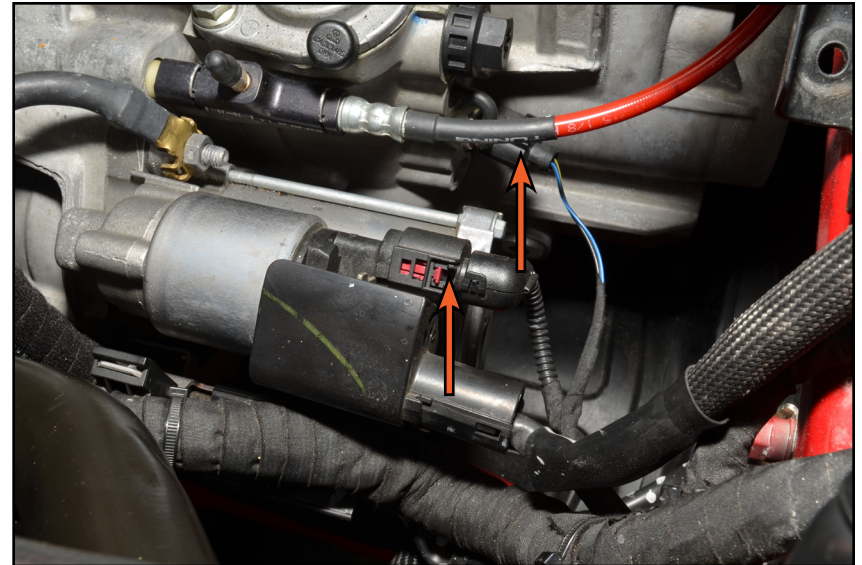

### Step 4: 13mm & 18mm Deep Sockets, Ratchet

Remove the ground cable nut from the end stud on the upper starter bolt. Do not remove the upper starter bolt, we will remove this bolt in a later step. It may be helpful to thread the nut back onto the stud for now to keep from losing it.

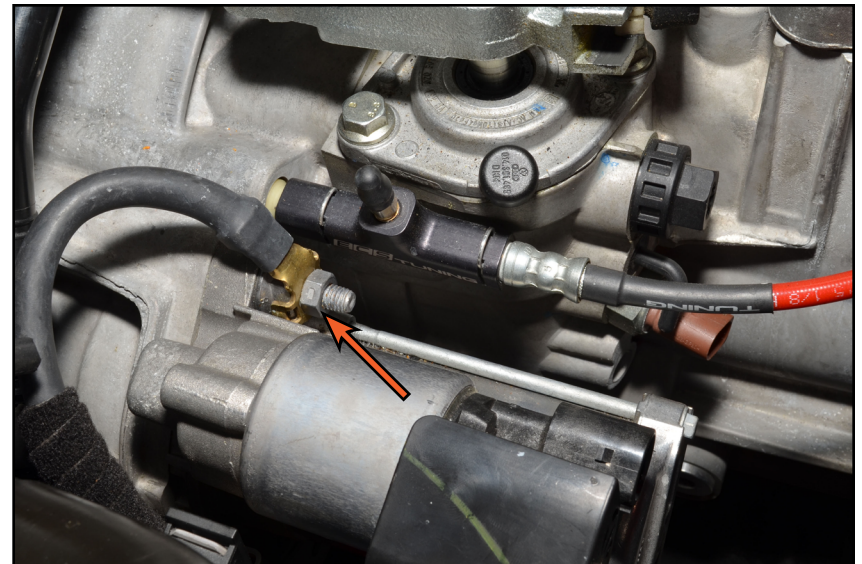

## REMOVING THE TRANSMISSION

### Step 5:

Slide back the plastic cover on the end of the starter cable.

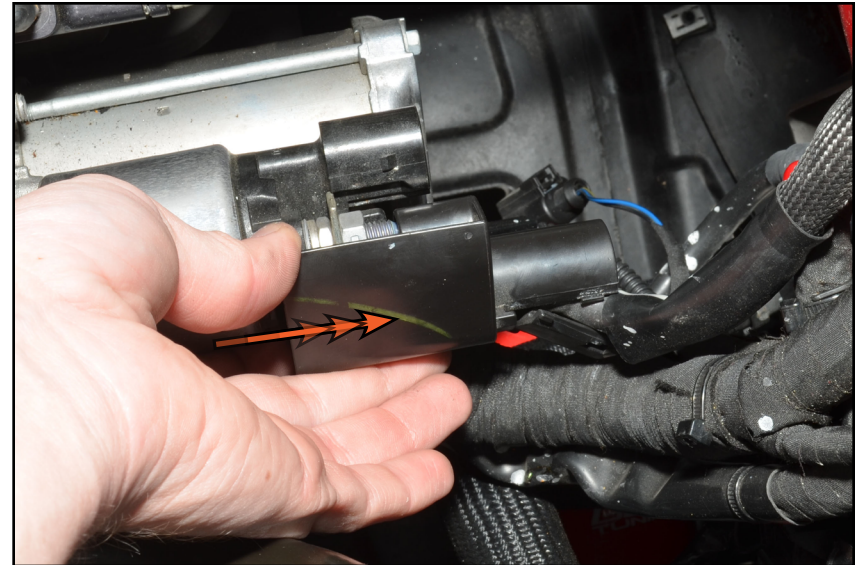

### Step 6: 13mm Deep Socket & Ratchet

Remove the nut holding the cable to the starter stud, pull the cable off and secure it out of the way.



## REMOVING THE TRANSMISSION

**Step 7:** T25 Torx, Flat Blade Screwdriver

Safely raise and support the vehicle, then remove the insulation panel or skid plate, depending on what you have installed. The MK7 pictured here is equipped with the original lower insulation panel (highlighted in green).

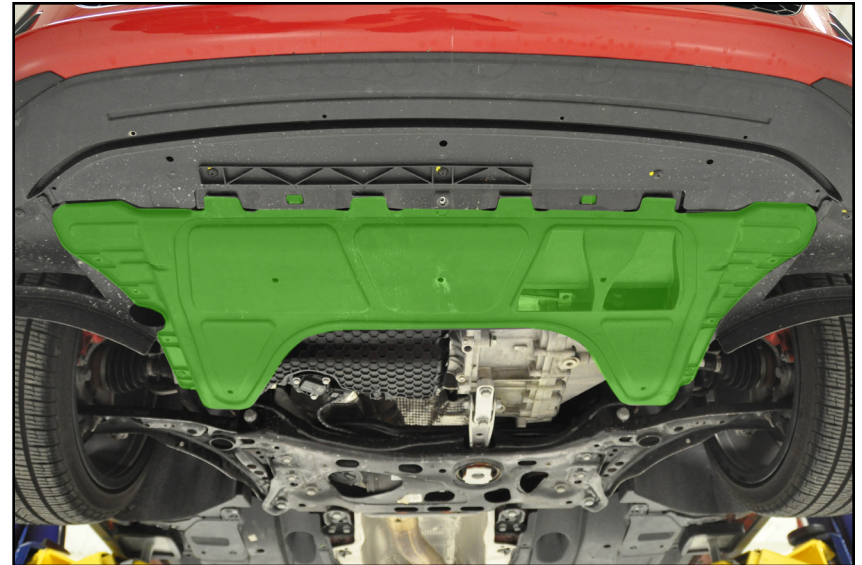

**Step 8:** 17mm Socket & Breaker Bar, T25 Torx

Remove both front wheels, then remove the lower wheel liners (highlighted in green).



## REMOVING THE TRANSMISSION

### Step 9: 13mm & 18mm Deep Sockets, Ratchet

Remove the harness bracket from the end stud on the lower starter bolt, then thread the nut back onto the stud to keep from losing it. Next, remove the lower starter bolt.

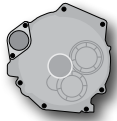

If you have decided to use our bolt storage template, thread the nut from step 6 onto this bolt and store them in location #2.

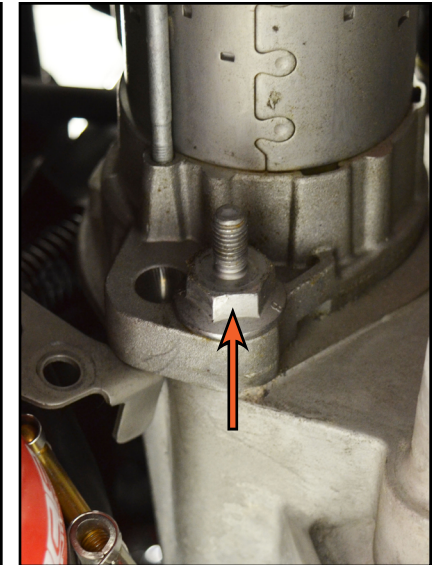
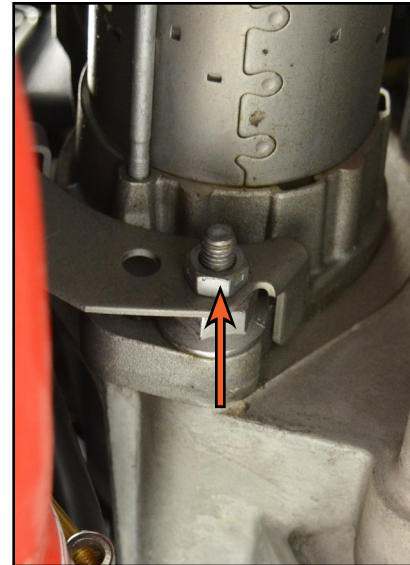

### Step 10:

Remove the intercooler inlet hose.



## REMOVING THE TRANSMISSION

### Step 11: Trim Removal Tool

Release the two wiring harness clips from the charge pipe (arrows).



### Step 12: T30 Torx

Remove the lower charge pipe mounting screw. It is located just above the front LH corner of the oil pan. Leave the charge air pipe in place at this time, we will remove it at a later step.



This screw will remain “trapped” in place in the charge air pipe after it has been loosened.

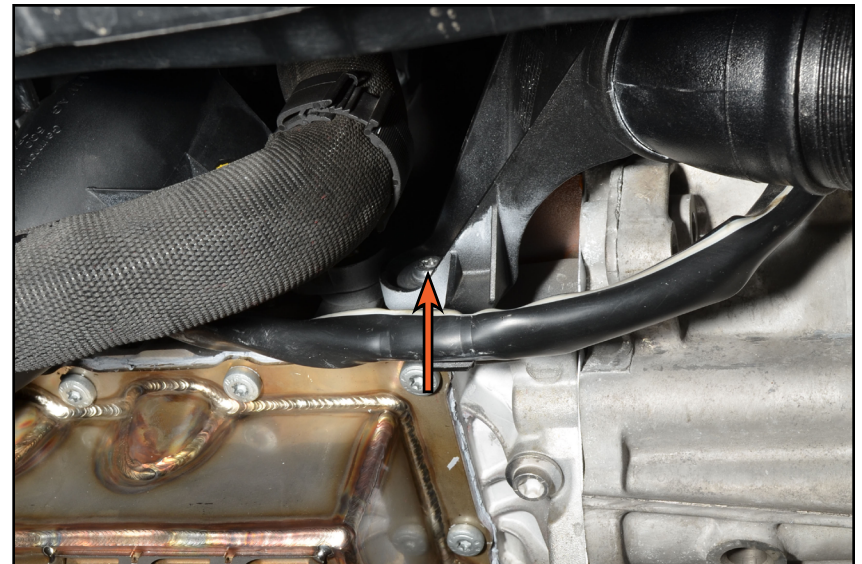



## REMOVING THE TRANSMISSION

### Step 13:

Remove the upper starter bolt, then remove the starter motor from the vehicle.



If you have decided to use our bolt storage template, thread the nut from step 6 onto this bolt and store them in location #2.



### Step 14: T30 Torx

Remove the upper charge pipe mounting screw. It is located just in front of the high pressure fuel pump on the LH side of the cylinder head. Loosen the hose clamp at the end of the charge pipe.

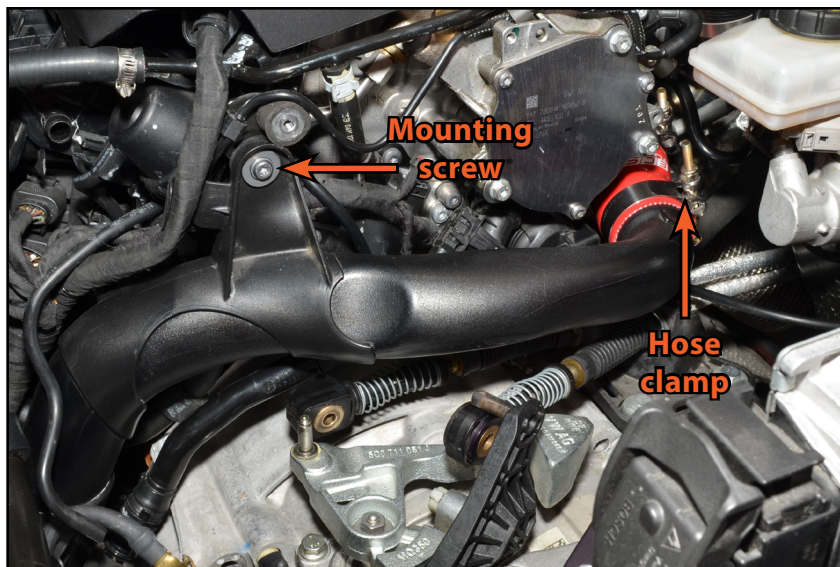

## REMOVING THE TRANSMISSION

### Step 15:

Remove the charge pipe by lifting it upwards as shown, be careful to not snag any of the wiring harnesses below while removing it.



### Step 16: 13mm Deep Socket & Ratchet

Locate the two bolts and one nut that hold the shifter cable bracket in place. Remove them all and secure the cable bracket up out of the way using mechanics wire.

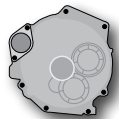

If you have decided to use our bolt storage template, thread the nut onto one of the bolts, then store these bolts in location #13.

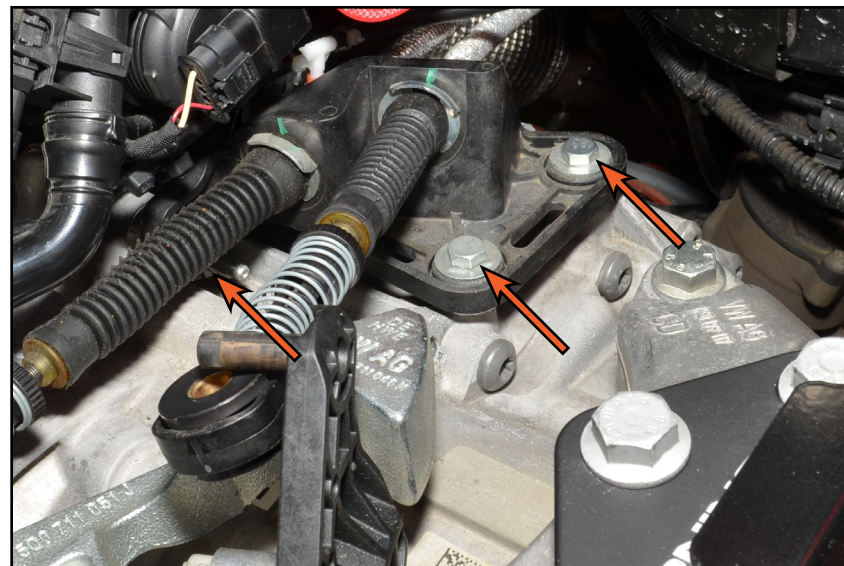

## REMOVING THE TRANSMISSION

### Step 17: Small Hook or Pick Tool

Remove the retaining clip on the transmission side of the bleeder block (LH photo), then gently pull the bleeder block off of the inlet of the clutch slave cylinder (RH photo). Have a rag nearby to wipe up any spills, and be sure to keep the brake fluid inside the line from dripping onto any painted surfaces.



**CAUTION:** Brake fluid is extremely harmful and corrosive. Be sure to wear safety glasses and gloves. Clean up any spills immediately and avoid any contact with painted surfaces.

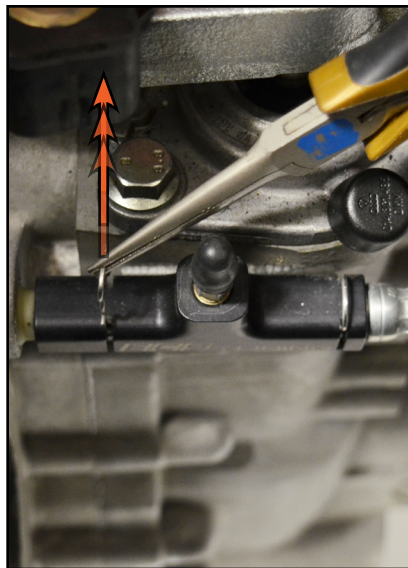

### Step 18:

Route the bleeder block and the clutch line around the back side of the transmission mount, then secure them to the wiring harness above the brake master cylinder with a zip tie as shown in the photo.

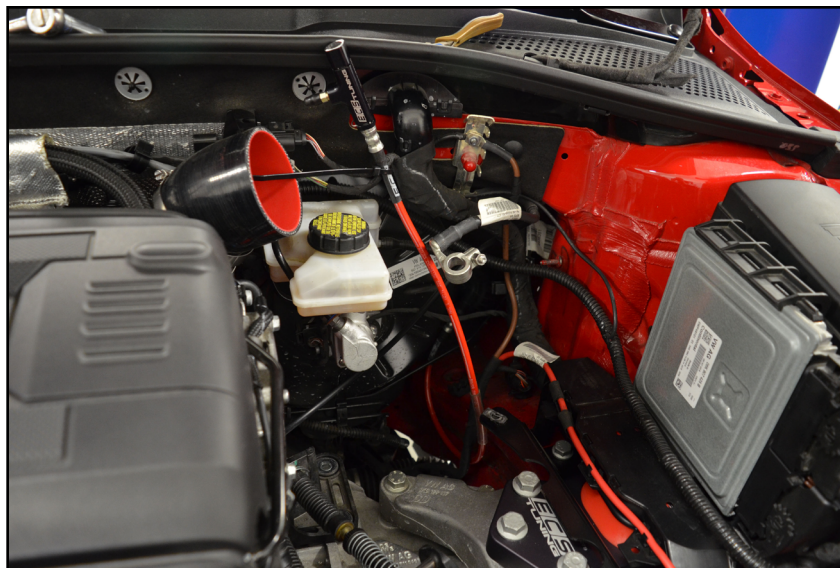

## REMOVING THE TRANSMISSION

### Step 19: Flat Blade Screwdriver

Remove the engine cover, then remove the engine support hook cover.



### Step 20: Engine Support Bar

Now it's time to install an engine support bar to hold the engine in place while we work. Begin by positioning the legs of the engine support bar securely inside the fenders. Secure the lifting hook of the engine bar to the engine lift bracket, then tension the lifting hook until it just begins to lift the engine.



## REMOVING THE TRANSMISSION

### Step 21: 16mm Wrench or Socket & Ratchet

Remove the two bolts for the RH inner CV heat shield, then rotate the shield around the half shaft and remove it.

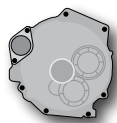

If you have decided to use our bolt storage template, store this bolt in location #14.

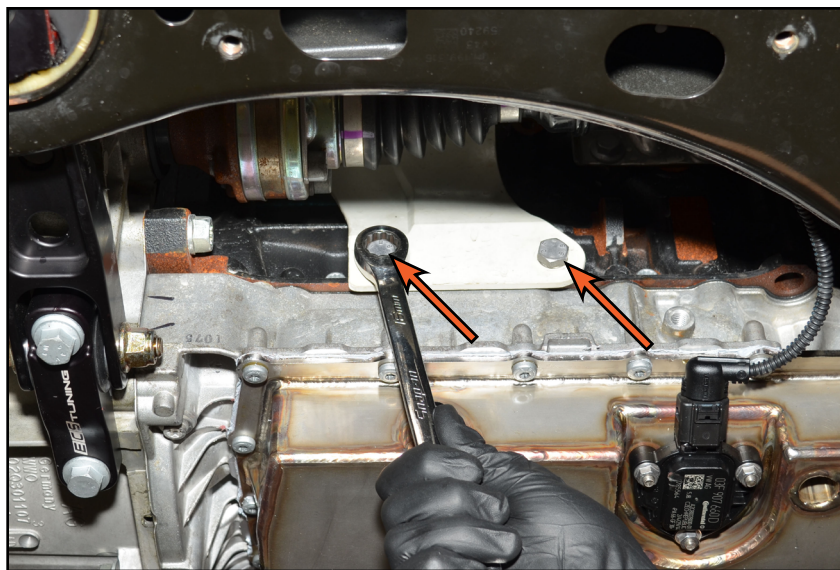

### Step 22: 24mm 12-Point Socket, Impact Wrench or Breaker Bar

Remove the bolt which secures the LF outer CV joint into the spindle.



This bolt is very tight. If you do not have an impact, you can loosen it using a breaker bar, but do not loosen it with the wheel on the ground. This will damage the wheel bearing. Have someone keep firm pressure on the brakes to keep the drive hub from rotating while you loosen the bolt.



## REMOVING THE TRANSMISSION

### Step 23: M10 Triple Square Socket & Ratchet

Mark **BOTH** axles with paint for easy alignment during reassembly (LH photo).

Remove the inner bolts from **BOTH** axles (RH photo), then tie the RH CV shaft up and out of the way using mechanics wire (not shown).



Look between the RH CV drive flange and the back of the engine. Some vehicles are equipped with an additional flywheel shield in this location. Our vehicle is not. If yours is equipped with this it must be removed at this time so the drive flange will clear the shield when removing the transmission (6mm Allen bolt).

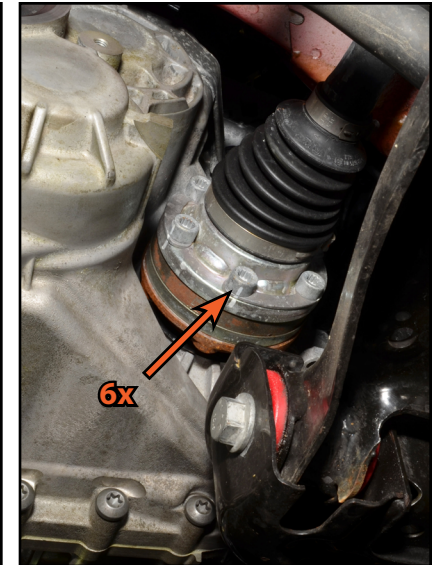
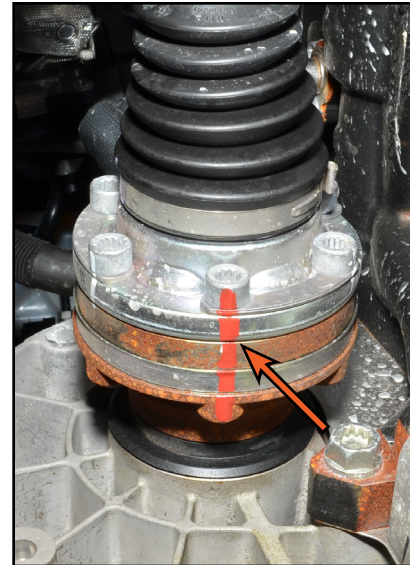

### Step 24: 10mm Socket & Ratchet, 16mm Socket & Breaker Bar

Remove the nut which secures the headlight leveling sensor bracket. Remove the three nuts which secure the ball joint to the LH lower control arm.

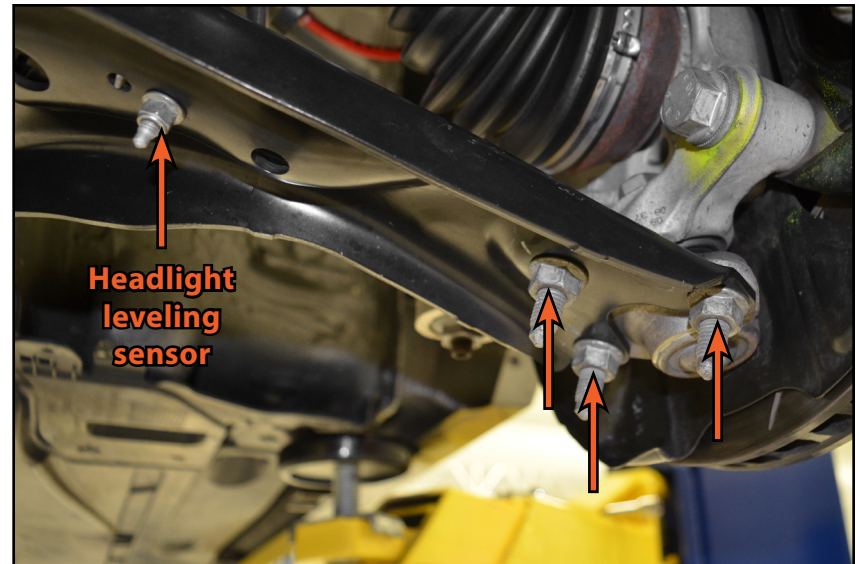

## REMOVING THE TRANSMISSION

### Step 25:

Pull the CV shaft out of the spindle, swing the control arm down and remove the CV shaft.

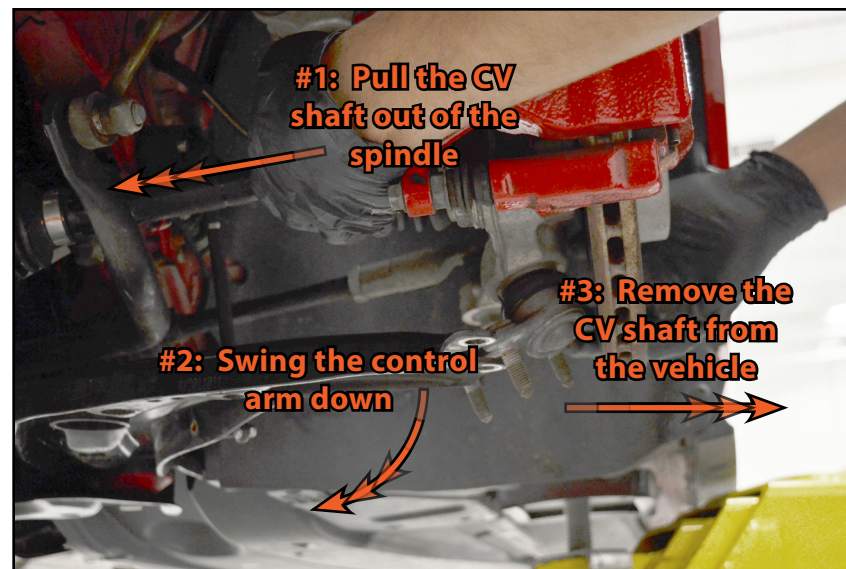

### Step 26: 13mm Socket & Ratchet

Remove the two bolts holding the exhaust downpipe bracket to the subframe.

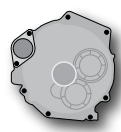

If you have decided to use our bolt storage template, store this bolt in location #9.



## REMOVING THE TRANSMISSION

### Step 27:

If your vehicle is equipped with an oil level sensor on the bottom of the oil pan, disconnect it at this time so the wiring harness is not stretched when tilting the engine for transmission removal.

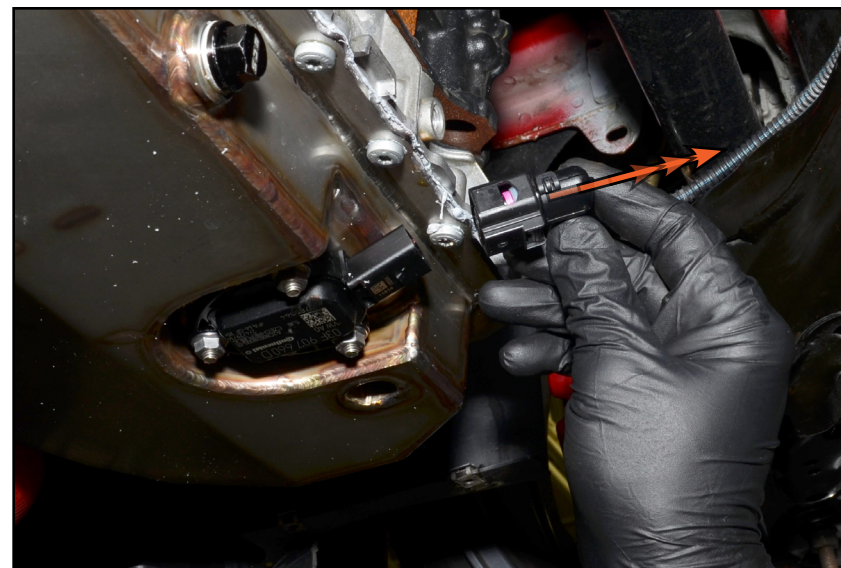

### Step 28: 16mm & 21mm Sockets, Breaker Bar

Remove the three pendulum support bolts and slide the support out of the subframe.



If you have decided to use our bolt storage template, store these bolts in location #10.

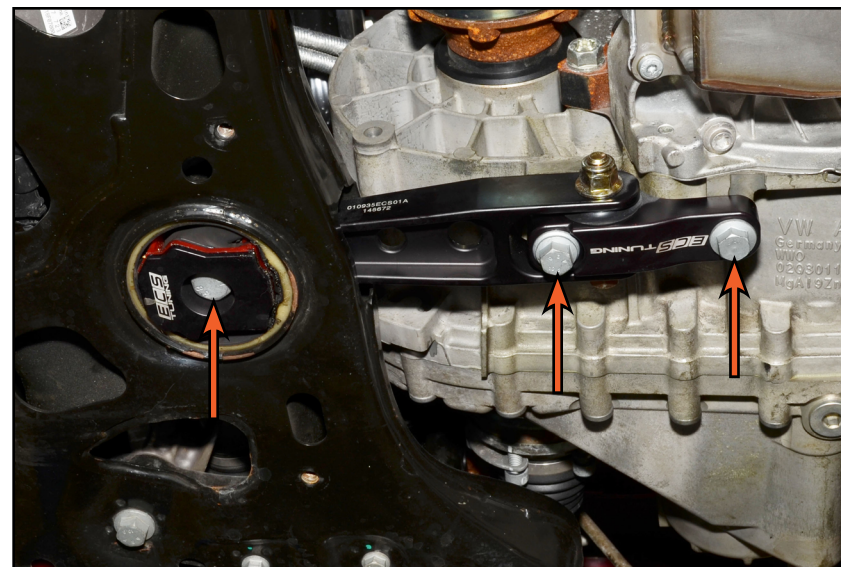



## REMOVING THE TRANSMISSION

### Step 29: 18mm Socket & Breaker Bar

Remove the three transmission mount bolts (LH photo).

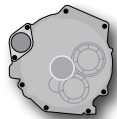

If you have decided to use our bolt storage template, store this bolt in location #11.

Remove the three bolts from the transmission bracket (RH photo).



If you have decided to use our bolt storage template, store this bolt in location #15.

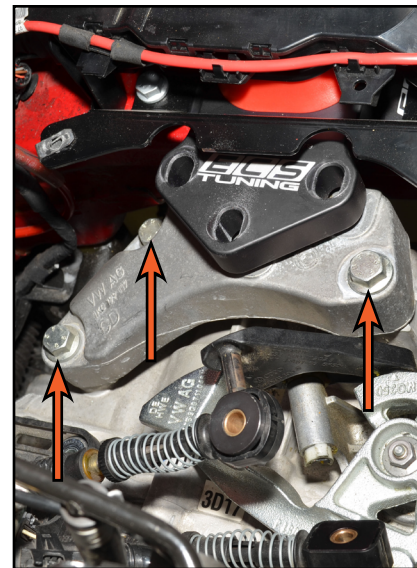

### Step 30:

Lower the transmission about two inches by loosening the center screw on the engine bar, then remove the transmission bracket.



## REMOVING THE TRANSMISSION

### Step 31:

Remove the front-to-back shift cable from the selector lever using the following method:

1. Pull up lightly on the spring tab of each retaining clip then slide the clip off of the lever pin.
2. Slide the cable end off of the lever pin.

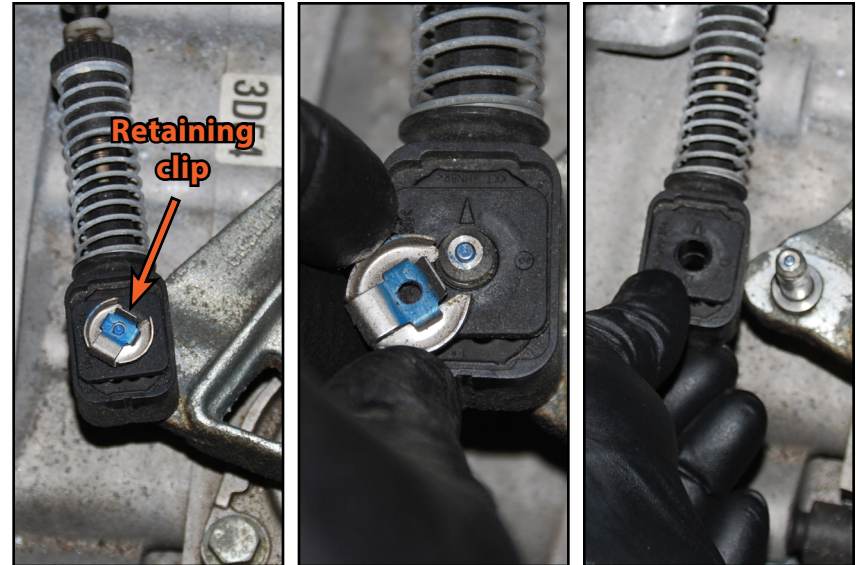

### Step 32: Needle Nose Pliers

Remove the side-to-side shift cable from the relay lever. The cable end is retained by a small plastic nub on the end of the relay lever pin. You may be able to pull this cable end off by hand, however if it is too tight, insert a small pair of needle nose pliers between the cable end and relay lever and gently pry it off.

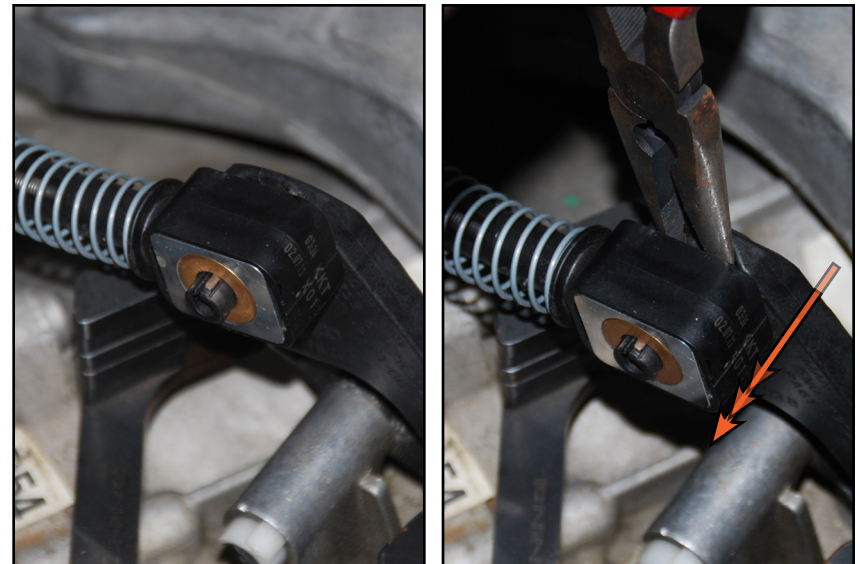

## REMOVING THE TRANSMISSION

### Step 33: 18mm Deep Socket & Breaker Bar

Remove both upper bell housing bolts.

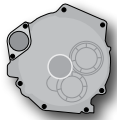

If you have decided to use our bolt storage template, store these bolts in location #'s 3 & 4.

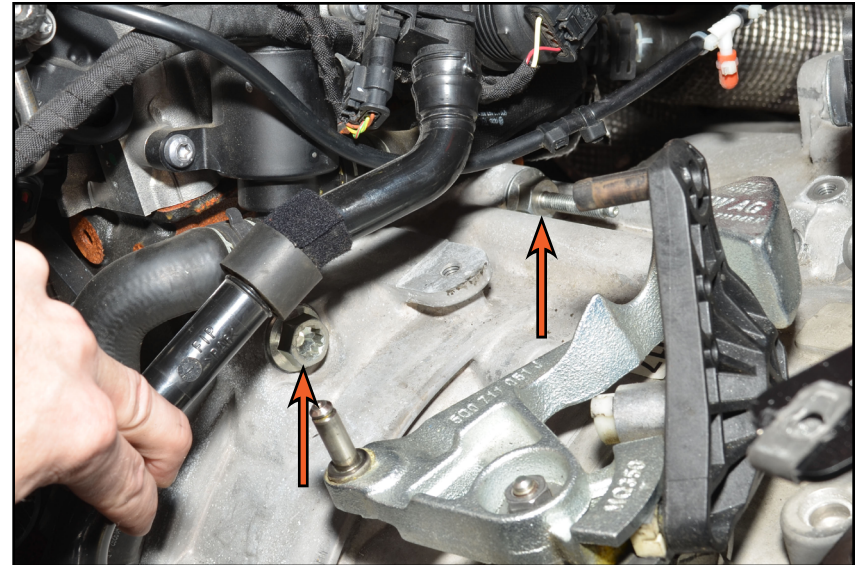

### Step 34:

Pull the plastic retaining clip off of the relay lever by hand, then slide the relay lever out of the shift lever and remove it.

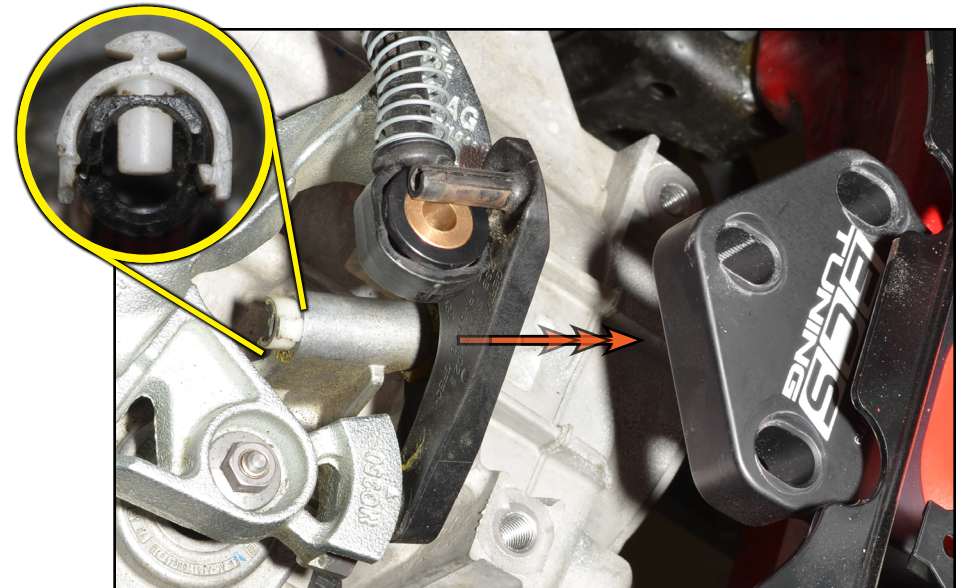

## REMOVING THE TRANSMISSION

### Step 35: 13mm Socket & Ratchet

Remove the selector shaft nut.



### Step 36:

Pull the selector lever off of the selector shaft. You may have to gently wiggle it side to side until it releases. Be patient and work the lever gently until it is free. You may have to use a puller if it is stuck, but it can normally be removed without one.



There is one double tooth on the selector lever and selector shaft, this allows the lever to only be installed one way.



**CAUTION:** Do not hammer on the end of the selector shaft or pry on the selector lever or the selector shaft can be damaged.

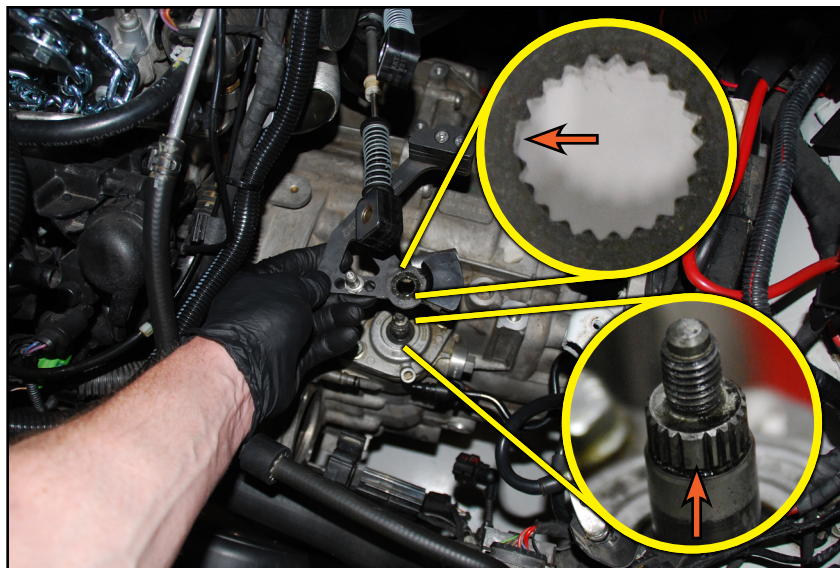

## REMOVING THE TRANSMISSION

### Step 37: 18mm Socket & Ratchet

Remove the rear bell housing bolt.



If you have decided to use our bolt storage template, store this bolt in location #5.



We have found that it is considerably easier to remove and install the transmission if you remove the RH CV drive flange. It is easy to remove and will save you a lot of time and effort. Continue with [step 38](#) for instructions on how to remove it, or skip to [step 40](#) to proceed with the clutch install.

### Step 38: Pry Bar, 6mm Allen

To remove the allen-head bolt, thread two CV bolts into the CV flange. Then lever a pry bar between the two as shown in order to hold the flange stationary. You will now be able to loosen and remove the bolt.

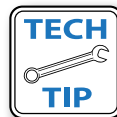

A long allen wrench or an extended allen bit socket will work best for this bolt.



We are showing drive flange removal with the transmission out of the vehicle in order to show you clearer pictures.

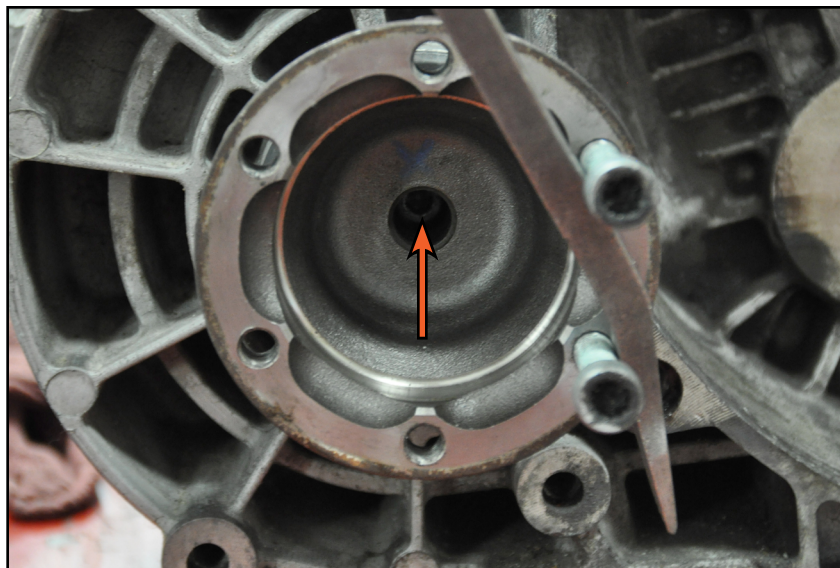
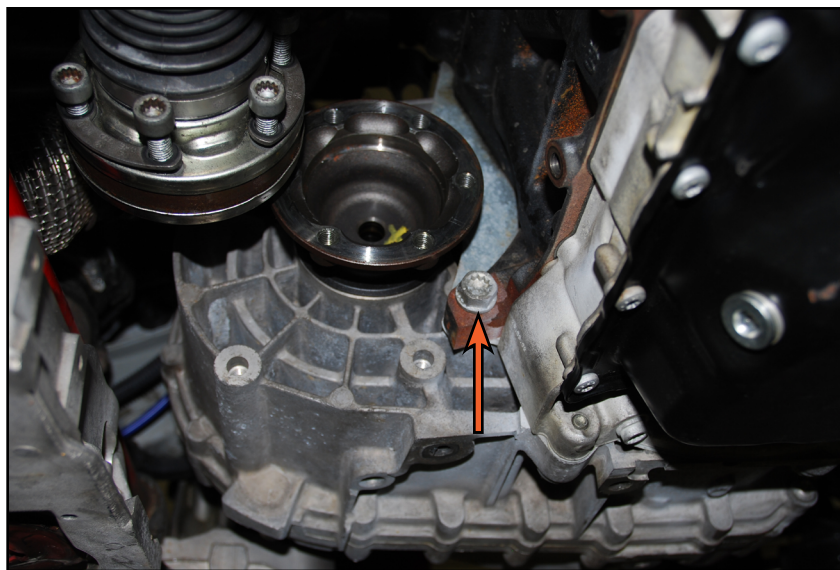

## REMOVING THE TRANSMISSION

### Step 39:

With the bolt removed, simply slide the drive flange out.



When removing the drive flange with the transmission still in the vehicle, you may have to drop the RH CV shaft down to gain adequate clearance.



### Step 40: Transmission Jack

Raise the transmission jack in place and secure the transmission to the jack using hold down straps.



Double check the engine support bar to make sure it is secure and the engine is properly supported. Also be sure to have a friend help you remove the transmission, it is very heavy.



## REMOVING THE TRANSMISSION

### Step 41: 18mm Socket & Ratchet

Remove the front transmission bell housing bolt and the two lower bell housing bolts, shown here without the jack in place for clarity.

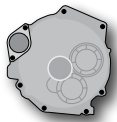

If you have decided to use our bolt storage template, store the front bell housing bolt in location #8, and store the two lower bell housing bolts in location #'s 6 & 7.

### Final Removal Steps:

Remember to work slowly and cautiously during removal and follow these general steps and tips:

Separate the transmission from the engine by pulling it back from the engine block.

Rotate the differential upwards, then angle the transmission toward the front and guide it around the flywheel.

Pull the transmission back until it completely clears the flywheel and clutch.

Slowly lower and adjust the engine bar and transmission jack as necessary to gain the required clearance for removal.

Once the transmission is clear, lower it completely and transfer it to a work surface.

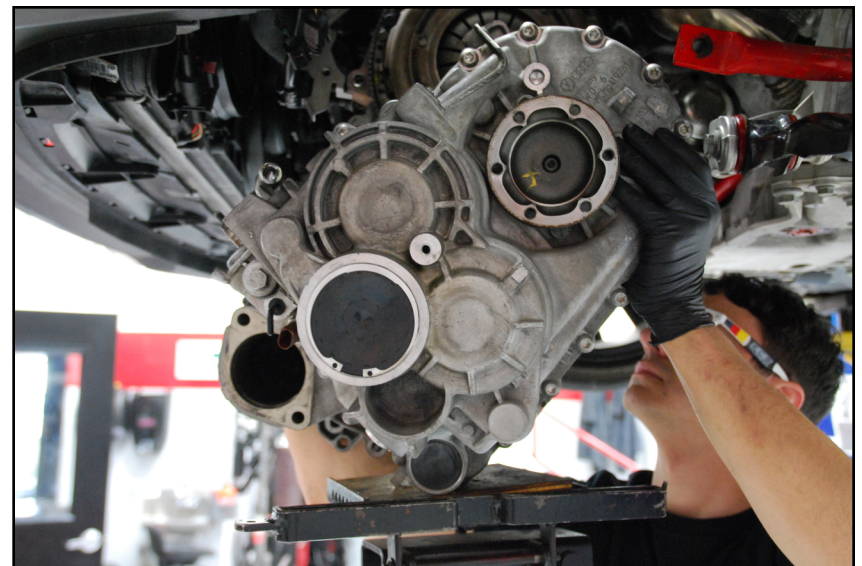
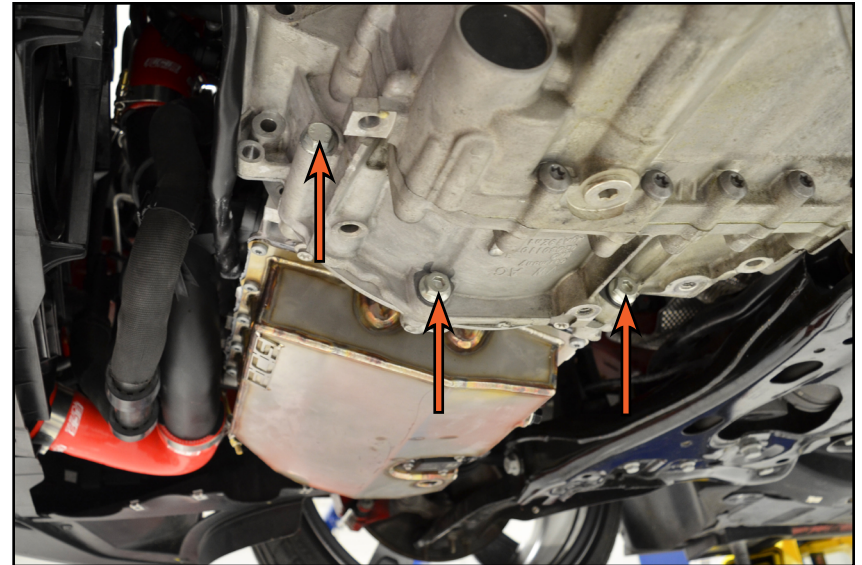

## REMOVING THE ORIGINAL FLYWHEEL AND CLUTCH

**Step 1:** 9mm 12-Point Socket & Ratchet, Flat Blade Screwdriver



**READ THIS ENTIRE STEP BEFORE PROCEEDING**



Loosen, but do not remove all six pressure plate bolts (arrows). Next, keep a flat blade screwdriver within reach, then place one hand on the pressure plate to keep it in place and remove all six bolts in an alternating pattern. Now, using both hands, slowly pull the pressure plate off of the flywheel dowel pins (D). As you pull it off, make sure that you grab the clutch disc so it does not fall and remove it along with the pressure plate. You may have to pry the pressure plate off the dowel pins (D) using a flat blade screwdriver. Depending on whether the pressure plate bolts are original or not, the socket size required for removal may vary.

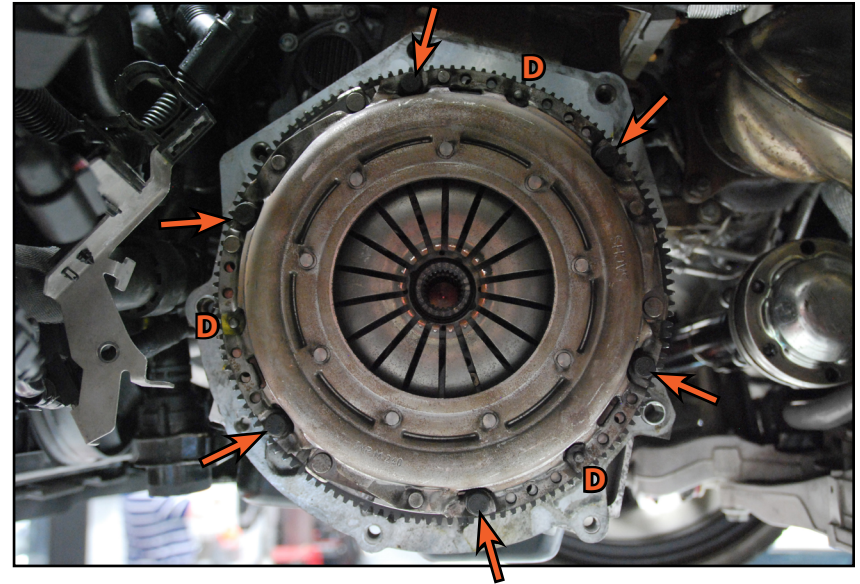

**Step 2:** M12 Triple Square Socket & Breaker Bar, Pry Bar

Loosen all eight flywheel bolts, then remove seven of them. Firmly grip the flywheel and remove the last bolt, then pull the flywheel off the end of the crankshaft. Depending on whether the flywheel bolts are original or not, the socket size required for removal may vary.

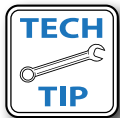

An impact can be used to easily remove the flywheel bolts. If you do not have an impact, thread two of the old pressure plate bolts back into place and lever a pry bar between them to keep the engine from turning while you break the flywheel bolts loose.

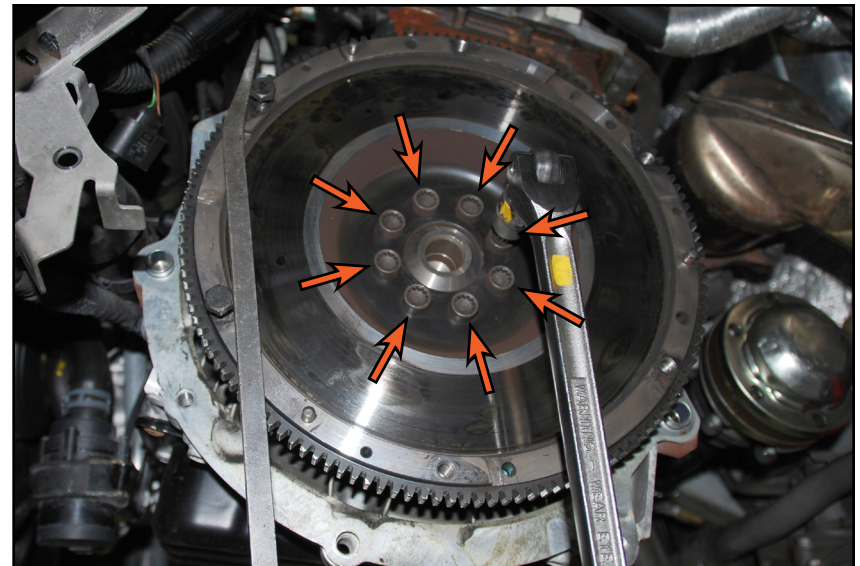



## CLEANING THE ENGINE BLOCK

Thoroughly clean the end of the crankshaft, engine block, and separator plate. Closely inspect the rear main seal for any signs of leakage, replace it if necessary. Make sure that both alignment dowels are located in the block in the locations shown. If not, remove them from the transmission bell housing and reinstall them in the block. It is common for the separator plate fall off during transmission removal. Reposition it by hooking the center tab behind the rear main seal plate then resting it on the two alignment dowels.

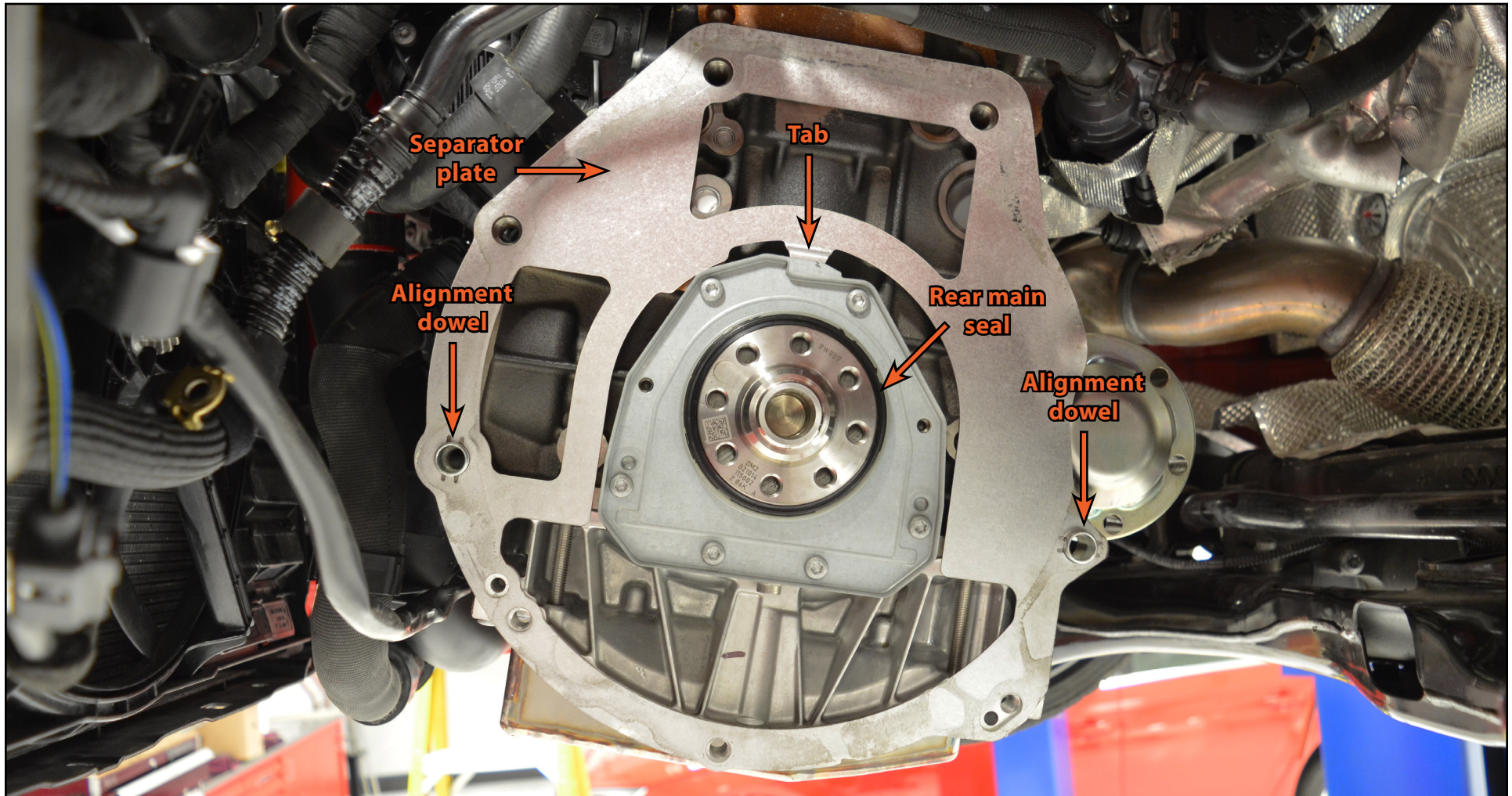

# INSTALLING THE NEW FLYWHEEL AND CLUTCH

## Step 1: M12 Triple Square Socket & Ratchet

Install the flywheel into place on the end of the crankshaft, then install all eight bolts and thread them in just until they are fully seated. The new bolts have loctite pre-applied on the threads so you may have to use a ratchet to thread them in.



The flywheel bolt holes are offset, they will only line up in one position.

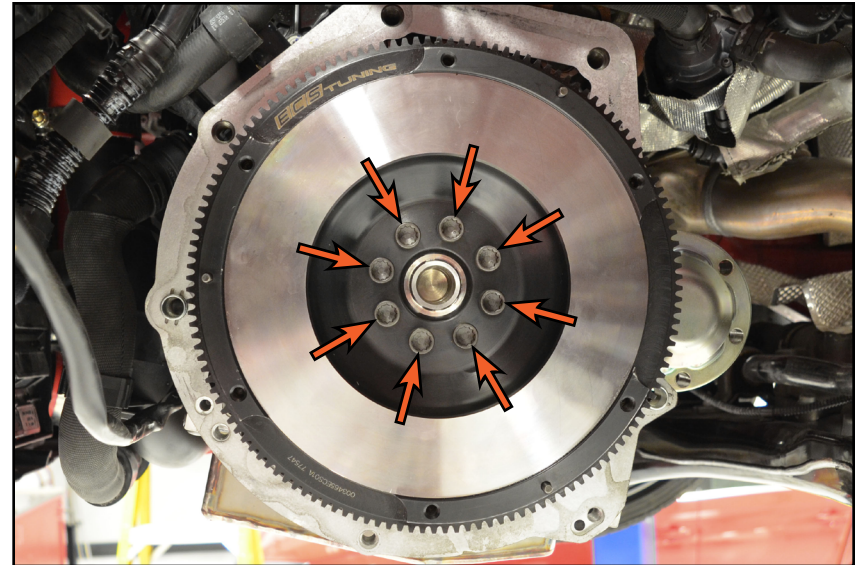

## Step 2: M12 Triple Square Socket, Torque Wrench, Breaker Bar, Paint Pen

Torque the flywheel bolts in the sequence shown on the right in the three different stages listed below.

1. 30 Nm (22 Ft-lbs)
2. 60 Nm (44 Ft-lbs)
3. Additional 90°



When you begin stage 3, mark each bolt with paint after you tighten it the additional 90° so you don't lose track of which ones have been tightened.



Please reference the illustration below **BEFORE** installing your new ECS Tuning Clutch Kit.

The clutch disc hub is to be installed inside the recess in the flywheel. Failure to properly orient the clutch disc hub will cause higher than normal clutch pedal engagement height, poor clutch feel/performance, clutch slip, and reduced service life.

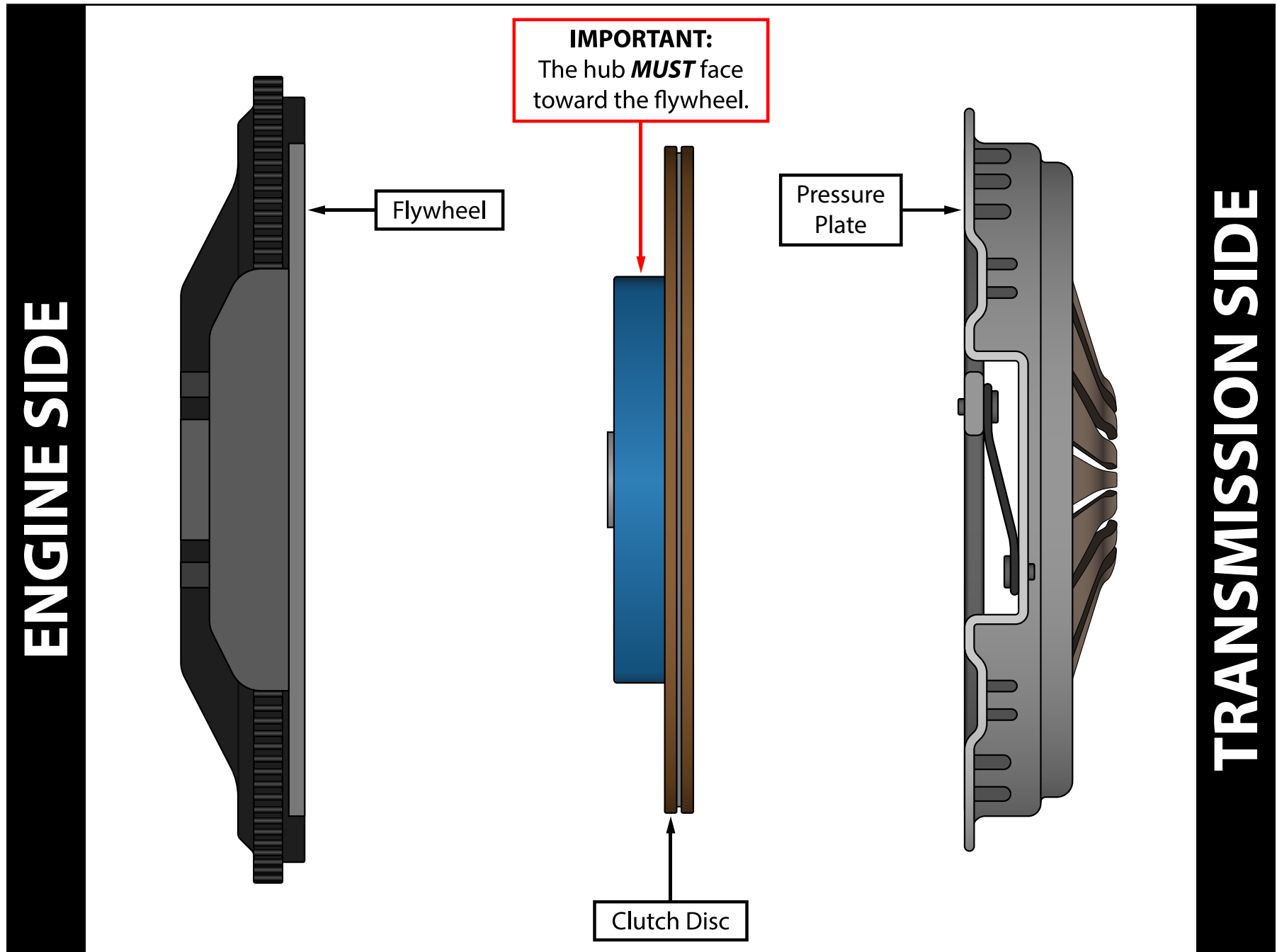

## INSTALLING THE NEW FLYWHEEL AND CLUTCH

### Step 3:

Wipe the surface of the new flywheel using brake cleaner and a rag to remove any dirt, oil, or contaminants.



### Step 4:

Inspect the new clutch disc. You will see "PRESSURE PLATE SIDE" etched into one side. This side needs to face **AWAY** from the engine when installed.

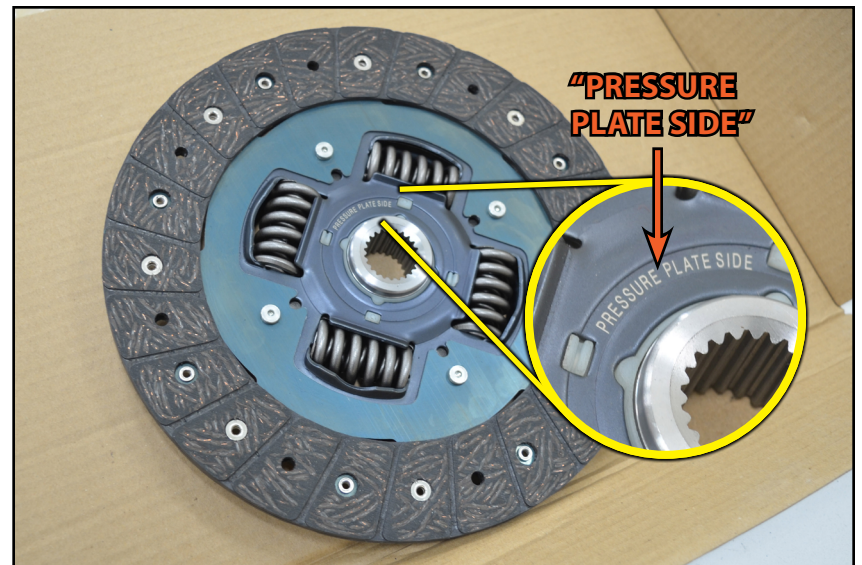

# INSTALLING THE NEW FLYWHEEL AND CLUTCH

## Step 5:

Slide the clutch disc onto the splines of the transmission input shaft to make sure it fits correctly and slides on easily.



This is a general precaution which should be taken with every clutch installation. It is very uncommon that you would encounter a problem such as a clutch disc that was packaged wrong or manufactured incorrectly, but it is always better to check.

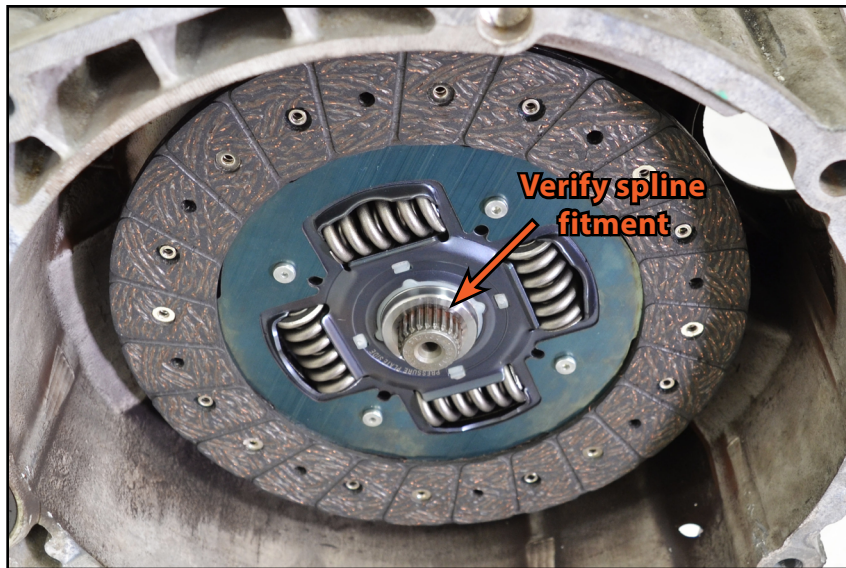

## Step 6: Clutch Alignment Tool

Hold the clutch disc onto the surface of the flywheel with the "PRESSURE PLATE SIDE" facing you, then insert the alignment tool through the disc and into the end of the crankshaft.



**CAUTION:** Make absolutely sure to install the clutch disc in the proper orientation. If the clutch disc is installed backwards it **WILL NOT** function properly.

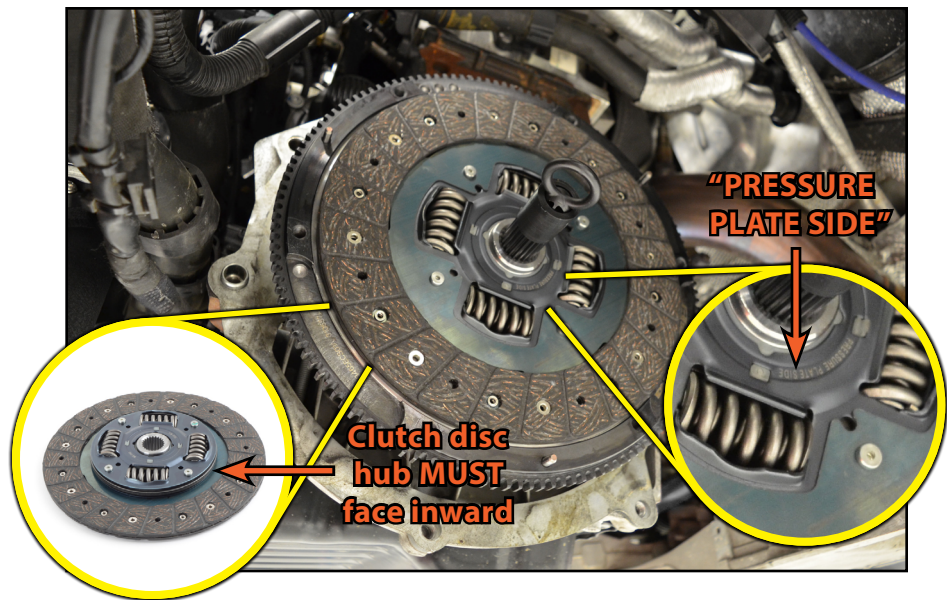

## INSTALLING THE NEW FLYWHEEL AND CLUTCH

### Step 7:

Wipe the surface of the new pressure plate using brake cleaner and a rag to remove any dirt, oil, or contaminants.

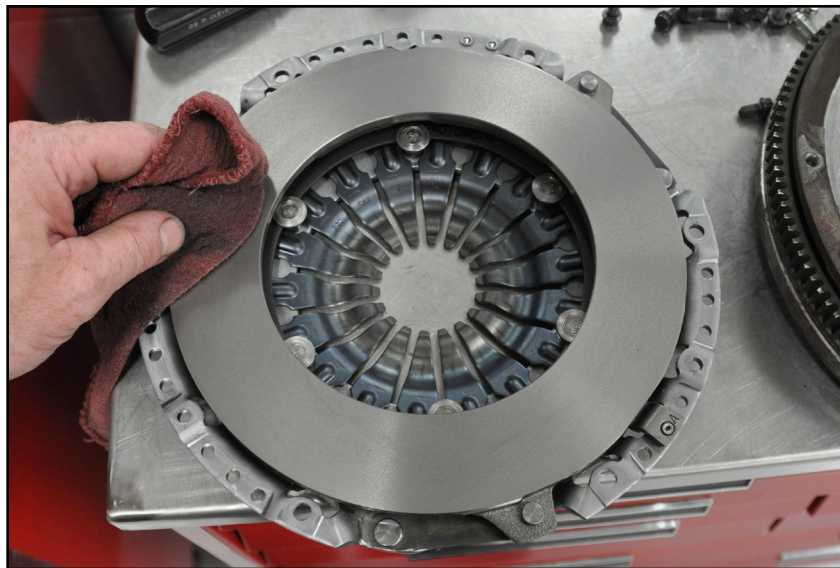

### Step 8: 6mm Hex (Allen) Socket & Torque Wrench

Install the pressure plate over the alignment tool and disc, onto the flywheel. Make sure all three dowel pins are lined up (D), then push the pressure plate into place (this may require a few light taps with a rubber mallet due to manufacturing tolerances between the dowel pins and the matching bores in the pressure plate).

Start each of the pressure plate bolts by hand, then tighten them evenly in the sequence shown on the right until they are fully seated. Be sure to use the new pressure plate bolts included in the kit (inset photo).

Torque the pressure plate bolts to 20 Nm (15 Ft-lbs) using the same sequence shown on the right. Remove the alignment tool after the bolts are torqued.

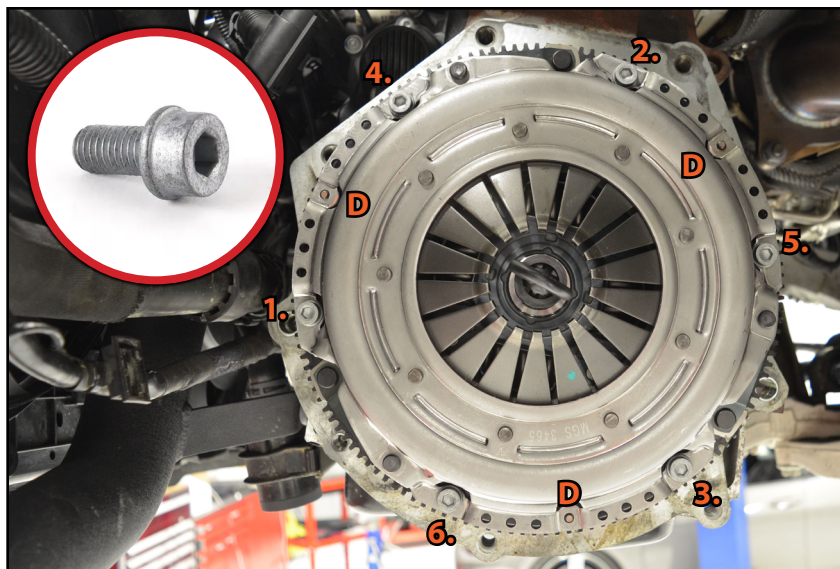

## PREPARING THE TRANSMISSION FOR INSTALLATION

### Step 1: 9mm Deep Socket & Ratchet

Remove the three retaining bolts and pull the throwout bearing/slave cylinder off of the bell housing.

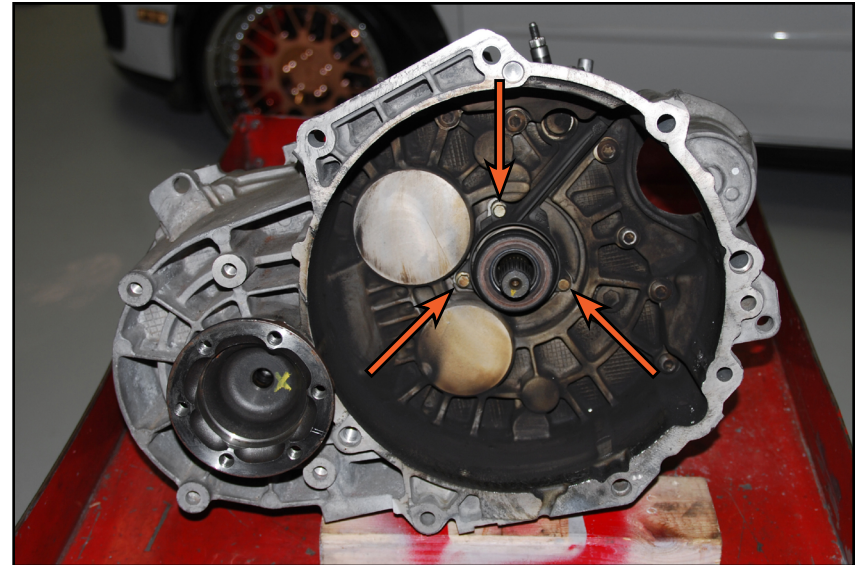

### Step 2:

Thoroughly clean the bell housing and the splines on the input shaft. Inspect the input shaft seal for any signs of leakage, replace if necessary.

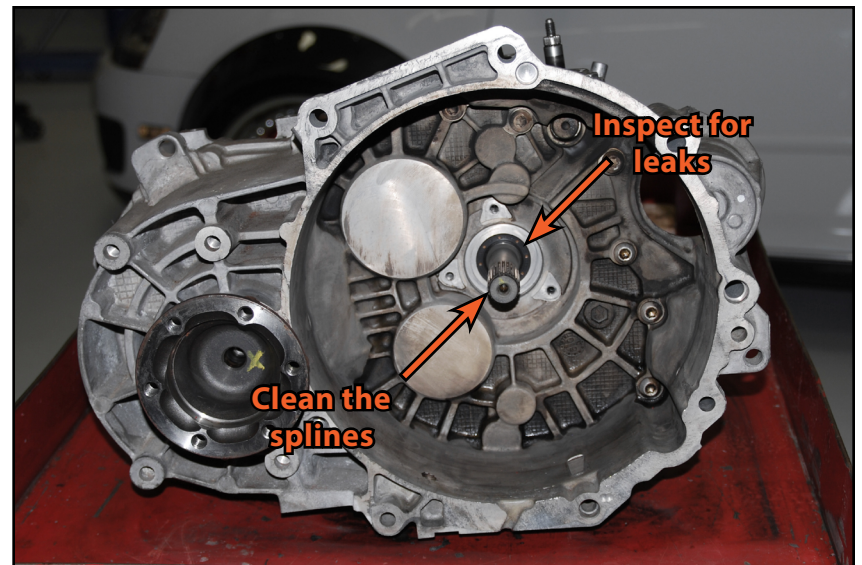

## PREPARING THE TRANSMISSION FOR INSTALLATION

### Step 3: 9mm Deep Socket & Torque Wrench

Install the new throwout bearing/slave cylinder into place using the new bolts included with the kit and torque them to 12 Nm (9 Ft-lbs).

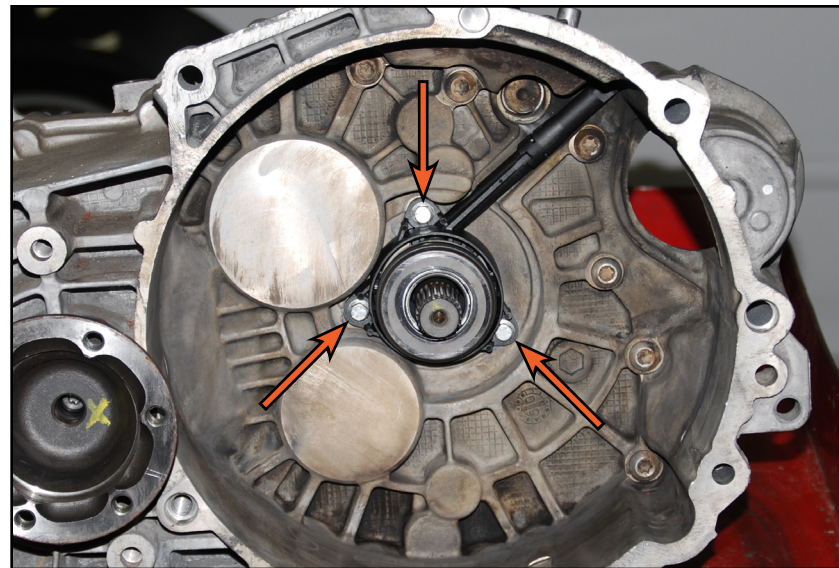

### Step 4:

Evenly apply a very light coating of grease onto the input shaft splines. You don't want to put very much grease on here, any excess grease could be slung onto the clutch friction surface and undo all of your hard work!

***You are now ready to install the transmission!***





## REINSTALLING THE TRANSMISSION

Reinstalling the transmission is basically the reverse of removal, however for convenience and accuracy we have provided this checklist along with tips and important information.

Secure the transmission on a transmission jack, then raise it up and guide it into place until it is fully seated against the engine block. Be patient and adjust the angles of the engine and transmission until they easily slide together.

Install the two lower bell housing bolts until they are fully seated but do not tighten them at this time.

Install the front bell housing bolt until it is fully seated but do not tighten it at this time.

Install the rear bell housing bolt until it is fully seated but do not tighten it at this time.

Remove the transmission jack.

Install the two upper bell housing bolts until they are fully seated but do not tighten them at this time.

Check to make sure no wires or cables are pinched between the bell housing and engine block.

Torque the upper bell housing bolts to 80 Nm (59 Ft-lbs).

Torque the lower bell housing bolts to 40 Nm (30 Ft-lbs).

Torque the front bell housing bolt to 40 Nm (30 Ft-lbs).

Torque the rear bell housing bolt to 80 Nm (59 Ft-lbs).

Install the RH CV drive flange (if removed during transmission removal) and torque the bolt to 33 Nm (24 Ft-lbs).

Install the selector lever and shaft nut and torque the selector shaft nut to 20 Nm (15 Ft-lbs).

Install the relay lever and retaining clip.

## REINSTALLING THE TRANSMISSION

Install the transmission bracket and torque the bolts to 60 Nm (44 Ft-lbs) + 90 degrees.

Raise the transmission up to its normal installation position, then align the transmission mount as outlined in the instructions on [ES#3111609](#) (the transmission mount **MUST** be aligned per these instructions whether it is OEM or aftermarket).

Install the three transmission mount bolts and torque them to 60 Nm (44 Ft-lbs) + 90 degrees.

If equipped, reconnect the oil level sensor on the bottom of the oil pan.

If equipped, reinstall the flywheel shield behind the RH CV drive flange.

Slide the pendulum support into place.

Install the pendulum support to transmission bolts and torque them to 50 Nm (37 Ft-lbs) + 90 degrees.

Install the pendulum support to subframe bolt and torque it to 100 Nm (74 Ft-lbs) + 90 degrees.

Remove the engine support bar.

Install the exhaust downpipe bracket.

Install the LH CV shaft back into place.

Install the ball joint nuts and torque them to 60 Nm (44 Ft-lbs) for a cast steel control arm or 100 Nm (74 Ft-lbs) for a sheet steel or forged aluminum control arm.

Install the inner CV joint bolts for both axles, then torque them to 70 Nm (51 Ft-lbs) for 10mm bolts or 40 Nm (30 Ft-lbs) for 8mm bolts.

Install the RH inner CV joint heat shield.

Install the RH charge air hose.

## REINSTALLING THE TRANSMISSION

Install the charge air duct on the front of the engine.

Reconnect the MAP sensor and tighten the clamp on the top of the charge air duct.

Install the LH charge air hose.

Install the starter and torque both starter bolts to 80 Nm (59 Ft-lbs).

Install the harness bracket on the lower starter bolt.

Install the LF fender liner.

Install the LH outer CV bolt and torque it to the proper specification depending on whether it is a ribbed or non-ribbed bolt. (See pages 47, & 48).

**NOTE:** Once the initial torque is applied to the outer CV bolt, you can lower the vehicle to the ground to perform the final tightening of the bolt.

Remove the wheel center cap (so you can access the outer CV bolt for the final torque setting).

Install the wheel and torque the bolts to 120 Nm (89 Ft-lbs).

Install the starter cable and plastic cover.

Connect the starter solenoid.

Connect the reverse light switch.

Install the ground cable.

Install the clutch bleeder block.

## FINAL INSTALLATION STEPS

Install the shifter cable bracket.

Install the shift cables onto the relay lever and selector lever.

Install the battery tray and battery.

Bleed the air from the clutch hydraulic system and top off the brake fluid

- [See Pages 45 & 46 for details on how to bleed the clutch hydraulic system.](#)

Install the air box/intake system.

Install the lower insulation panel or skid plate.

Lower the vehicle to the ground and tighten the outer CV bolt the additional specified number of degrees (if required).

## CLUTCH BREAK-IN PERIOD

We strongly recommend 500-1,000 miles of light throttle driving (shifting under 4,500 RPM) to break-in your new clutch and flywheel.

Make an effort to shift through the gears as much as possible to evenly break in the clutch and flywheel.

Try to avoid over slipping the clutch (I.E.: prolonged bumper-to-bumper traffic, etc.) during the break-in period.

Avoid hard launches or quick shifting until after the break-in period has passed.

## CLUTCH HYDRAULIC SYSTEM: MANUAL BLEEDING

The ECS Tuning Clutch Bleeder Block has a one-way valve built into the bleeder screw. This makes bleeding the clutch hydraulic system an easy one-man job, there's no need for power or vacuum bleeding equipment. **If you have a stock bleeder block you will need someone to open and close the bleeder screw for you (same process used to manually bleed brakes).**

Here's the procedure:

- Remove the rubber bleeder screw cap.
- Using an 8mm wrench, crack the bleeder screw open by no more than ¼ turn.
- Attach a clear flexible hose to the bleeder screw.
- Inside the vehicle, push the clutch pedal to the floor by hand, then pull it up again slowly. Do this several times until the brake fluid runs clear and bubble-free through the bleeder hose.
- Add fresh brake fluid to the master cylinder to replace the fluid lost during bleeding.
- Close the bleeder and reinstall the rubber bleeder cap.
- Check clutch operation.

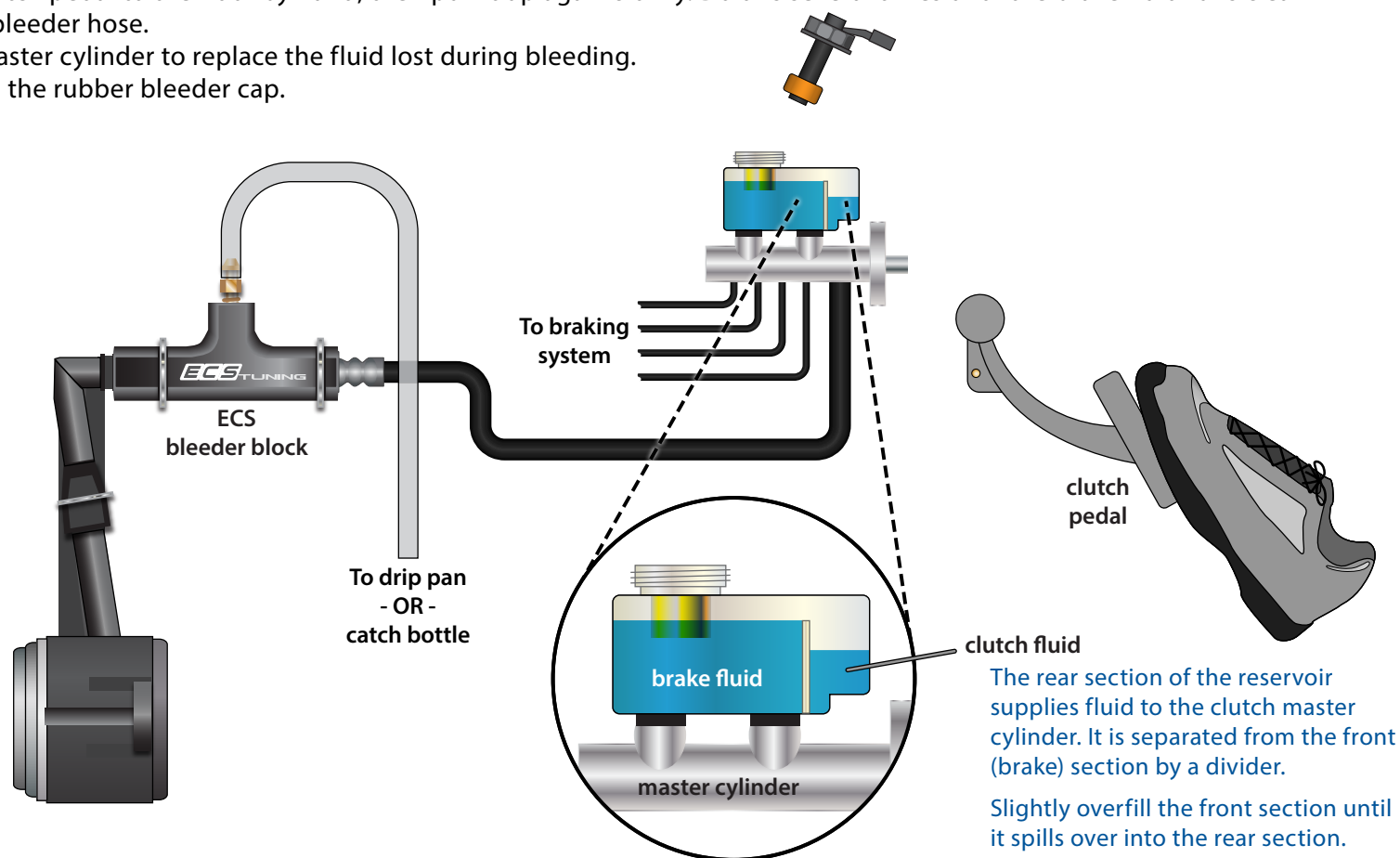

## CLUTCH HYDRAULIC SYSTEM: PRESSURE BLEEDING

A pressure bleeder can be used to assist with bleeding the clutch hydraulic system. This is especially helpful if you have an OEM clutch bleeder block. Using a pressure bleeder will negate the need to have an assistant open and close the bleeder screw for you, so this is an easy one-man job with the proper equipment.

Here's the procedure:

- Fill the pressure bleeder with brake fluid and connect it to the brake master cylinder (the brake and clutch hydraulic systems are fed from the brake master cylinder).
- Remove the bleeder screw cap.
- Attach the clear flexible hose from a bleeder catch bottle to the bleeder screw.
- Pump the pressure bleeder until the gauge reads 25-30 psi.
- Using an 8mm wrench, crack the bleeder screw open by no more than ¼ turn.

**\*\*DO NOT PUSH DOWN ON THE CLUTCH PEDAL ONCE THE BLEEDER SCREW HAS BEEN OPENED\*\***

- Watch the fluid inside the clear flexible hose, wait until you can see the brake fluid running clear and bubble-free through the hose.
- Close the bleeder and reinstall the rubber bleeder cap.
- Add brake fluid to the master cylinder as needed to bring the fluid up to the appropriate level.
- Check clutch operation.

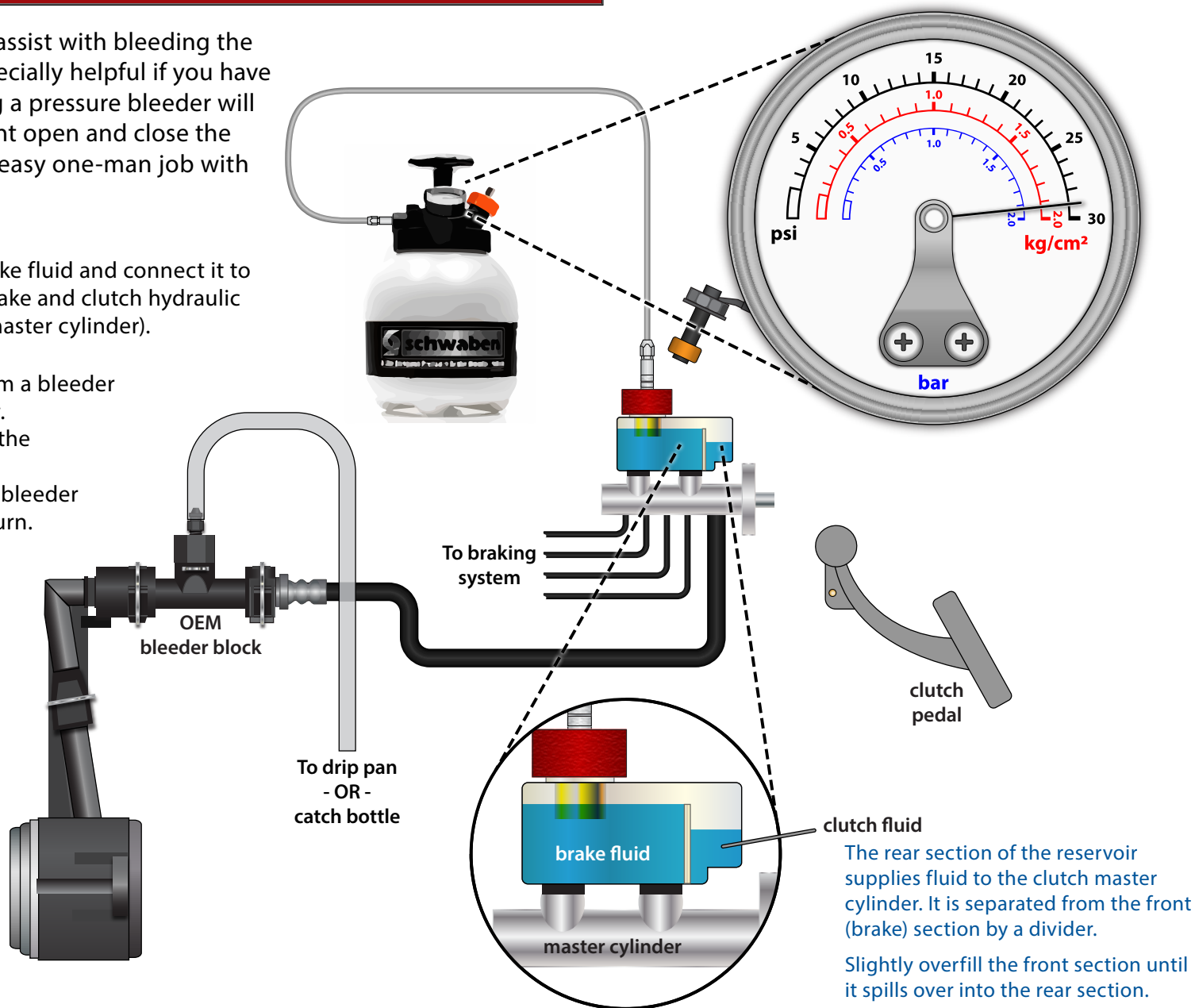

The rear section of the reservoir supplies fluid to the clutch master cylinder. It is separated from the front (brake) section by a divider.

Slightly overfill the front section until it spills over into the rear section.

**TORQUING TIPS**

**Torque to Yield or “Stretch” Bolts**

Many bolts will have a torque specification listed in the format - xx Nm (xx Ft-lbs) + xx degrees. These bolts are torque to yield bolts, commonly referred to as “stretch” bolts. The correct procedure for torquing these bolts is:

**Stage One** - Torque the bolt(s) to the initial Nm or Ft-lb specification. If there is more than one, be sure to torque them in the correct sequence.

**Stage Two** - Tighten or “stretch” the bolt(s) the additional specified number of degrees. If there is more than one, be sure to follow the correct sequence.

**Note** - Some bolts may have two or more stages of torquing before the final stage of “stretching” the bolts.

When tightening more than one bolt in a specified sequence, be sure to mark each fastener with paint *immediately* after performing the final stage or “stretching” of the bolts. This will ensure that you keep track of which bolts have already been “stretched”.

All Torque to Yield bolts should only be used once and should be replaced each time they are removed. If they are reused, they will not be able to achieve the proper clamping force with the specified torque.

**Lubrication**

Torque specifications are always listed for a dry fastener (*no* lubrication) unless specified otherwise.

Some fasteners require lubrication on the threads -or- on the contact surface while torquing. These fasteners will be listed with the specific location and type of lubrication required. Always follow manufacturers recommendations exactly.

Lubricating a fastener that is intended to be installed dry and then torquing it to factory specifications will increase the clamping force and stress on the fastener and components, which can result in damage or failure.

Do not lubricate the threads of any fastener unless it is specifically recommended by the manufacturer.

**Ribbed vs. Non-Ribbed Bolts**

Ribbed and Non-Ribbed bolts in the same location generally require a different torque specification.

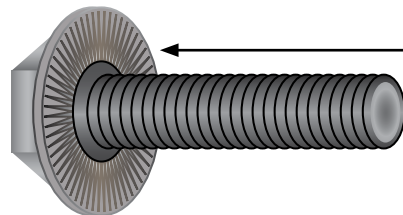

A ribbed bolt is identified by the ribs on the contact surface

A non-ribbed bolt is identified by the smooth contact surface

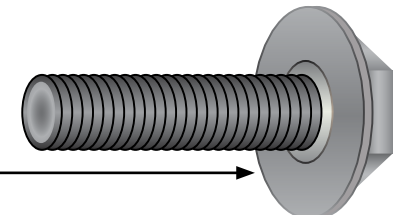

## TORQUE SPECIFICATIONS

Ball Joint Nuts (Cast Steel Control Arm).....	60 Nm (44 Ft-lbs).....	(Page 42)
Ball Joint Nuts (Sheet Steel or Forged Alum Control Arm) .....	100 Nm (74 Ft-lbs).....	(Page 42)
Front Bell Housing Bolt (M10x105mm).....	40 Nm (30 Ft-lbs).....	(Page 41)
Lower Bell Housing Bolts (M10x50mm) .....	40 Nm (30 Ft-lbs).....	(Page 41)
Rear Bell Housing Bolt (M12x65mm or M12x70mm).....	80 Nm (59 Ft-lbs).....	(Page 41)
Upper Bell Housing Bolts (M12x50mm or M12x55mm) .....	80 Nm (59 Ft-lbs).....	(Page 41)
CV Drive Flange (if removed during transmission removal).....	33 Nm (24 Ft-lbs).....	(Page 41)
Flywheel Bolts .....	<i>Stage One:</i> 30 Nm (22 Ft-lbs) <i>Stage Two:</i> 60 Nm (44 Ft-lbs) <i>Stage Three:</i> Tighten an additional 90 degrees.....	(Page 34)
Inner CV bolts (8mm).....	40 Nm (30 Ft-lbs).....	(Page 42)
Inner CV bolts (10mm).....	70 Nm (51 Ft-lbs) .....	(Page 42)
Outer CV bolt (Ribbed) .....	70 Nm (51 Ft-lbs) + 90 degrees .....	(Page 43)
Outer CV bolt (Smooth) .....	200 Nm (147 Ft-lbs) + 180 degrees.....	(Page 43)
Pendulum Support to Subframe .....	100 Nm (74 Ft-lbs) + 90 degrees .....	(Page 42)
Pendulum Support to Transmission .....	50 Nm (37 Ft-lbs) + 90 degrees .....	(Page 42)
Pressure Plate Bolts.....	20 Nm (15 Ft-lbs) .....	(Page 38)
Selector Shaft Nut .....	20 Nm (15 Ft-lbs) .....	(Page 41)
Slave Cylinder Bolts (Metal Slave).....	12 Nm (9 Ft-lbs) .....	(Page 40)
Slave Cylinder Bolts (Plastic Slave) .....	15 Nm (11 Ft-lbs).....	(Page 40)
Starter Bolts (M12x165mm) .....	80 Nm (59 Ft-lbs).....	(Page 43)
Transmission Bracket Bolts.....	60 Nm (44 Ft-lbs) + 90 degrees.....	(Page 42)
Transmission Mount Bolts .....	60 Nm (44 Ft-lbs) + 90 degrees.....	(Page 42)
Wheels.....	120 Nm (89 Ft-lbs).....	(Page 43)



## Your ECS Clutch & Lightweight Flywheel Kit installation is complete!



### These instructions are provided as a courtesy by ECS Tuning

Proper service and repair procedures are vital to the safe, reliable operation of all motor vehicles as well as the personal safety of those performing the repairs. Standard safety procedures and precautions (including use of safety goggles and proper tools and equipment) should be followed at all times to eliminate the possibility of personal injury or improper service which could damage the vehicle or compromise its safety.

Although this material has been prepared with the intent to provide reliable information, no warranty (express or implied) is made as to its accuracy or completeness. Neither is any liability assumed for loss or damage resulting from reliance on this material. SPECIFICALLY, NO WARRANTY OF MERCHANTABILITY, FITNESS FOR A PARTICULAR PURPOSE OR ANY OTHER WARRANTY IS MADE OR TO BE IMPLIED WITH RESPECT TO THIS MATERIAL. In no event will ECS Tuning, Incorporated or its affiliates be liable for any damages, direct or indirect, consequential or compensatory, arising out of the use of this material.