

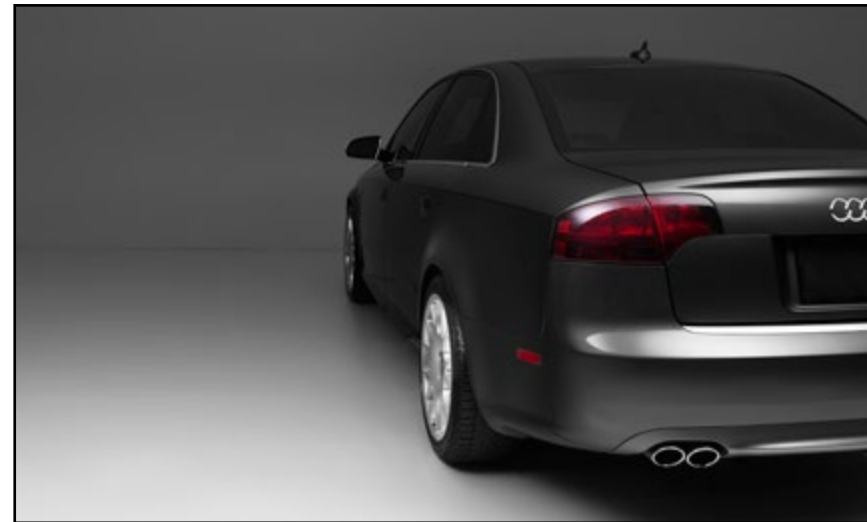

## Audi B7 A4 2.0T Timing Belt Kit Installation



Proper service and repair procedures are vital to the safe, reliable operation of all motor vehicles as well as the personal safety of those performing the repairs. Standard safety procedures and precautions (including use of safety goggles and proper tools and equipment) should be followed at all times to eliminate the possibility of personal injury or improper service which could damage the vehicle or compromise its safety.

## INTRODUCTION

### Audi B7 A4 2.0T Timing Belt Kit: ES#1876844, ES#1876845, ES#2581229, ES#2581230

The Audi B7 A4 2.0T Timing Belt Kits are assembled by the experts at ECS Tuning in order to include everything you need.

- “Ultimate” Kits include:
  - Timing and Accessory Belts, Camshaft Seal, Idler Pulleys, Water Pump, and all necessary hardware
- “Ultimate Plus” Kits include:
  - Everything in the “Ultimate Kit” plus 3 Liters of G13 Coolant
  - “Ultimate Plus” kits can also be purchased with or without our ECS Tuning Lightweight Underdrive Crank Pulley

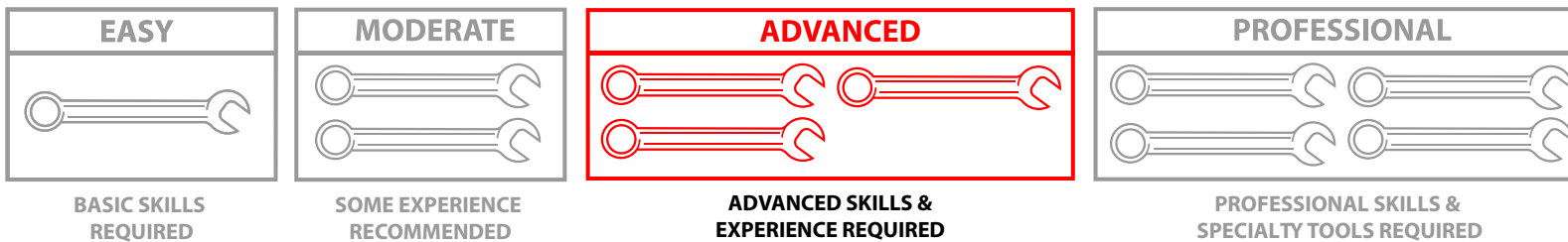

Timing Belt service is imperative to ensure the longevity of the engine in your Audi B7 A4 2.0T. An experienced technician will be able to complete this repair in a weekend, plan accordingly based on your experience level. Before you begin, read and familiarize yourself with these instructions and make sure you have all the required tools on hand. Thank you for purchasing our Audi B7 A4 2.0T Timing Belt Kit, we appreciate your business!

## TABLE OF CONTENTS

Kit Contents.....	<a href="#">pg.4</a>
Required Tools and Equipment.....	<a href="#">pg.6</a>
Shop Supplies and Materials.....	<a href="#">pg.6</a>
Installation Notes .....	<a href="#">pg.7</a>
Preparation and Safety.....	<a href="#">pg.7</a>
Drive Belt Routing Diagram.....	<a href="#">pg.8</a>
Timing Belt Routing Diagram .....	<a href="#">pg.9</a>
Front Lock Carrier - Service Position.....	<a href="#">pg.10</a>
Removing the Original Timing Belt.....	<a href="#">pg.20</a>
Replacing the Camshaft Seal .....	<a href="#">pg.30</a>
Installing the New Timing Belt .....	<a href="#">pg.33</a>
Bleeding the Cooling System.....	<a href="#">pg.41</a>
Using The VAG Connector Tool.....	<a href="#">pg.45</a>
Schwaben Tools .....	<a href="#">pg.46</a>

### NOTE

For this PDF we will be installing the Timing Belt Ultimate Plus Kit with the ECS Tuning Lightweight Underdrive Crank Pulley.

**KIT CONTENTS**

Timing Belt Ultimate Kit: [ES#1876844](#)

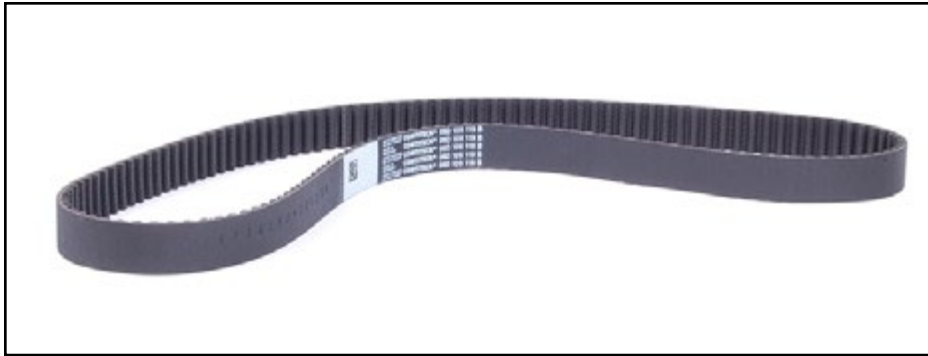

Timing Belt



Accessory Belt



Water Pump



Timing Belt Tensioner



Camshaft Gear Bolt



Crank Pulley Hardware



Tensioner and Idler Hardware



Camshaft Seal



Timing Belt Upper Idler Pulley



Timing Belt Lower Idler Pulley

## KIT CONTENTS

Timing Belt Ultimate Plus Kits: [ES#1876845](#), [ES#2581229](#), [ES#2581230](#)



Timing Belt Ultimate Kit



G13 Coolant - 1.5 Liter (2x)

• Included in Kits:

- [ES#1876845](#)
- [ES#2581229](#)
- [ES#2581230](#)



Lightweight Underdrive  
Crank Pulley

- Black Pulley included in:  
- [ES#2581229](#)
- Silver Pulley included in:  
- [ES#2581230](#)

## REQUIRED TOOLS

Note: The tools required for each step will be listed by the step number throughout these instructions.

Below is a list of the tools we used to install the timing belt and ECS lightweight crank pulley kit onto our Audi B7 A4 2.0T FSI. Additional tools may be required for any issues that arise during installation such as rust, corrosion, or broken and stripped fasteners. Tools with a part number listed are available on our website - click on their [ES# link](#) to view them.

- 1/4" Drive Ratchet ..... [ES#2093757](#)
- 1/4" Drive Extensions
- 3/8" Drive Ratchet ..... [ES#2765902](#)
- 3/8" Drive Torque Wrench..... [ES#2221245](#)
- 3/8" Drive Sockets: 10mm, 12mm, 13mm ..... [ES#2763772](#)
- 3/8" Drive Extensions
- 3/8" Drive Deep Sockets: 13mm
- Spark Plug Socket: 5/8" ..... [ES#9340](#)
- 1/2" Drive Ratchet
- 1/2" Drive Breaker Bar ..... [ES#2776653](#)
- 1/2" Drive 12-Point Socket: 19mm
- 1/2" Drive 6-Point Sockets: 13mm, 16mm
- Torx Bit Sockets: T20, T25, T30 ..... [ES#11418](#)
- Triple Square Bit Socket: M10..... [ES#1910125](#)
- Hammer
- Hex Bit (Allen) Socket: 6mm ..... [ES#11420](#)
- Hex Bit (Allen) Wrench: 8mm
- Open/Boxed End Wrenches: 13mm, 17mm..... [ES#2765907](#)
- Screwdrivers: Flat Blade & Phillips Head..... [ES#2225921](#)
- Torx Screwdrivers: T20, T25..... [ES#11417](#)
- Camshaft Locking Tool..... [ES#1844103](#)
- Camshaft Puller Kit ..... [ES#1844102](#)
- Ignition Coil Puller Kit..... [ES#2643082](#)
- VAG Connector Tool ..... [ES#2628676](#)
- Coolant Evacuation Tool Kit..... [ES#2712734](#)
- Locking Hose Clamp Pliers ..... [ES#2702616](#)
- Pliers
- Seal Puller and Seal Driver
- Paint Marker

## SHOP SUPPLIES AND MATERIALS

- Hand Cleaner/Degreaser..... Available at [ecstuning.com](http://ecstuning.com)..... [ES#2167336](#)
- Aerosol Brake Cleaner..... Available at your local auto parts store
- Shop Rags ..... Available at your local auto parts store
- Aerosol Spray Lubricant/Penetrating Oil..... Available at your local auto parts store

## INSTALLATION NOTES

- **RH** refers to the passenger side of the vehicle.
- **LH** refers to the driver side of the vehicle.
- Always use the proper torque specifications.
- If applicable to this installation, torque specifications will be listed throughout the document and at the end as well.
- Please read all of these instructions and familiarize yourself with the complete process **BEFORE** you begin.

## GENERAL PREPARATION AND SAFETY INFORMATION

ECS Tuning cares about your health and safety. Please read the following safety information. This information pertains to automotive service in general, and while it may not pertain to every job you do, please remember and share these important safety tips.

- Park your car in a safe, well lit, level area.
- Shut the engine off and remove the key from the ignition switch.
- Make sure any remote start devices are properly disabled.
- **ALWAYS** wear safety glasses.
- Make sure the parking brake is applied until the vehicle is safely lifted and supported.
- If using an automotive lift, be sure and utilize the factory specified lift points. Lifting a vehicle in an incorrect location can cause damage to the suspension/running gear.
- When lifting a vehicle using a jack, always utilize the factory specified lift points. Lifting a vehicle in an incorrect location can cause damage to the suspension/running gear. **ALWAYS** support the vehicle with jack stands.
- Always read and follow all safety information and warnings for the equipment you are using.



**Never get underneath a vehicle that is supported only by a jack. Always make sure that the vehicle is securely supported on jack stands.**

# DRIVE BELT ROUTING DIAGRAM

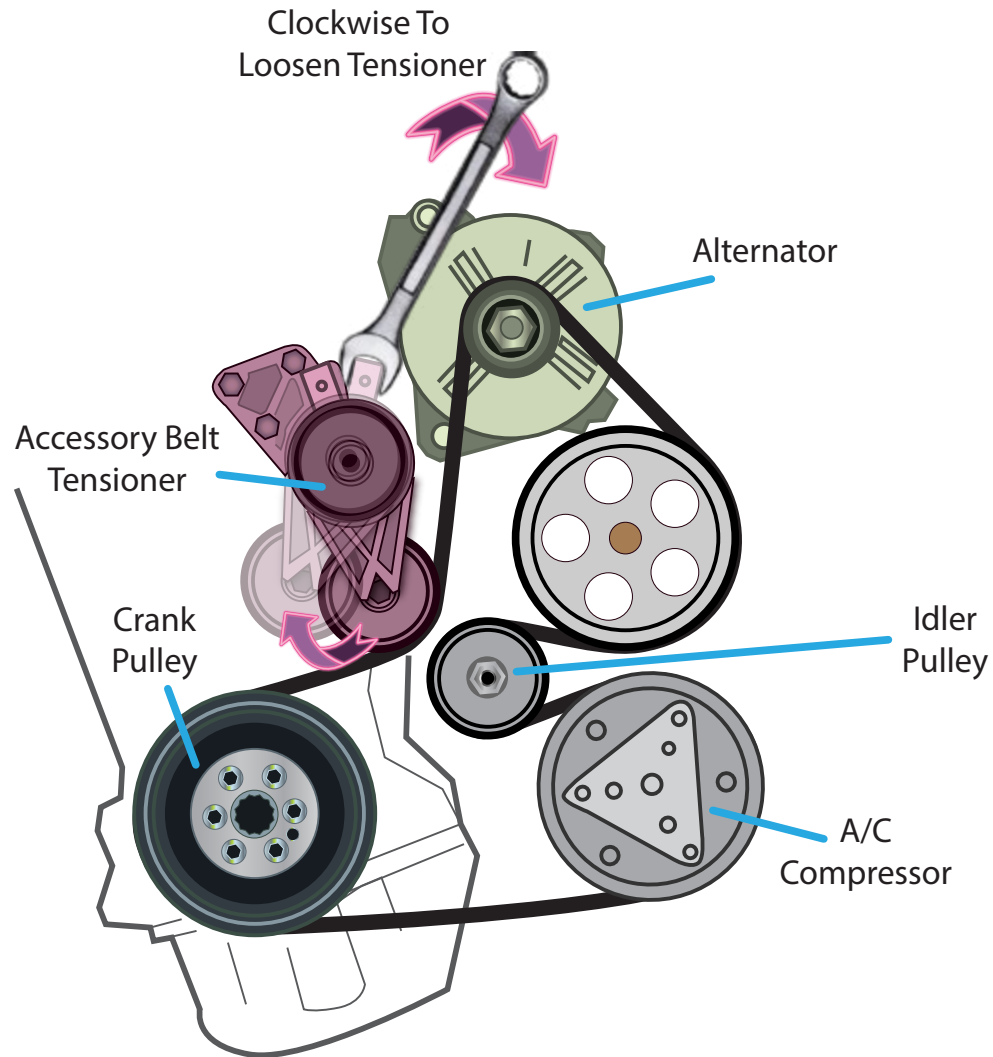



# TIMING BELT ROUTING DIAGRAM

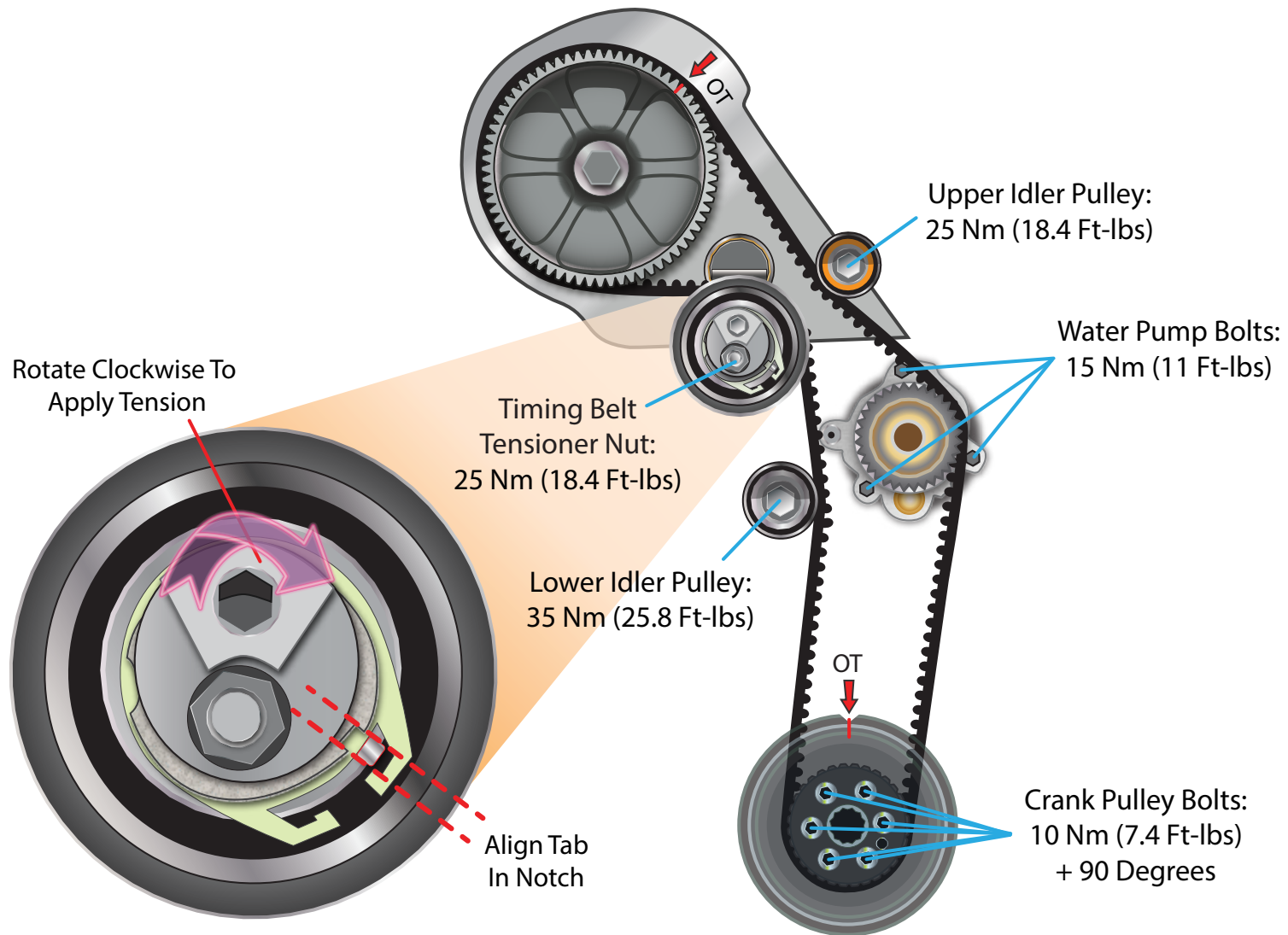

## FRONT LOCK CARRIER - SERVICE POSITION

### Step 1: T20 Torx Bit Socket & Ratchet - OR - Phillips Screwdriver

The following instructions show how to place a B7 A4 lock carrier into "service position", your vehicle may differ slightly.

Locate the two air scoop mounting screws and remove them. Depending on production date will you find that you may have either torx or phillips head fasteners.

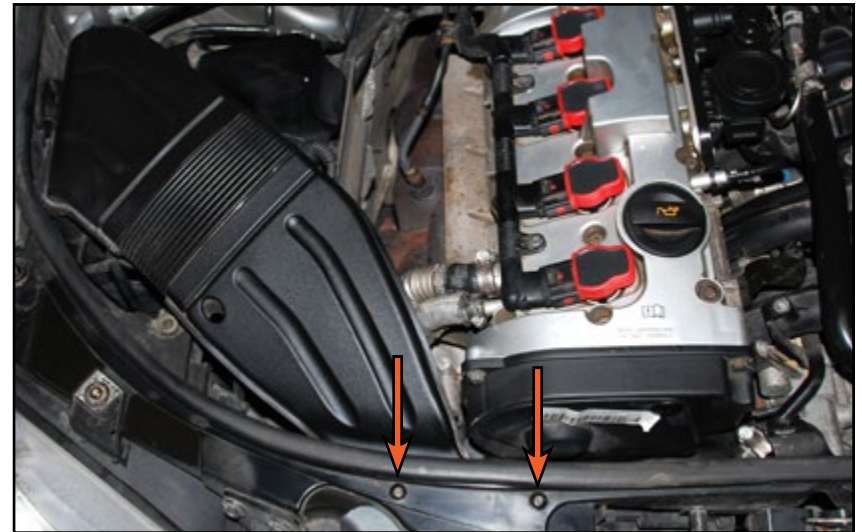

### Step 2:

Pull up on the intake duct at the location shown to separate it from the airbox, then pull it rearward to pull the air scoop out of the front core support and remove it from the vehicle.

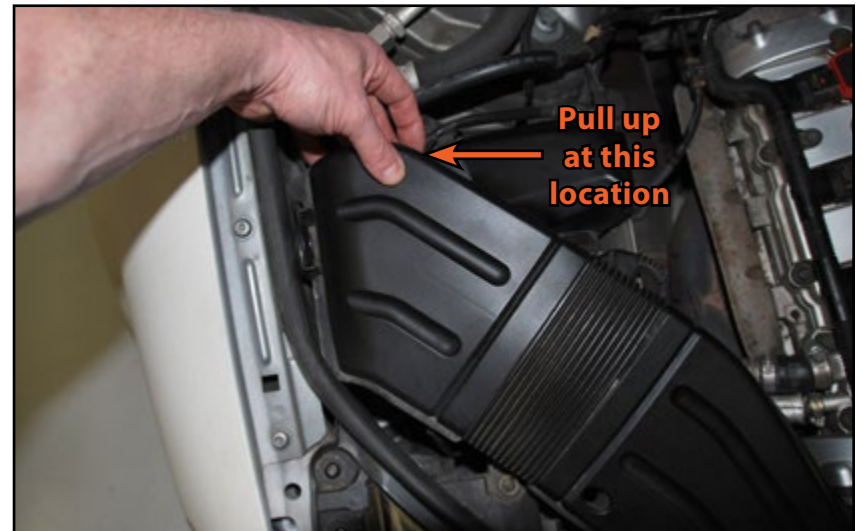

## FRONT LOCK CARRIER - SERVICE POSITION

### Step 3:

Remove the hood seal (highlighted in **RED**) from the front vehicle and set it aside.



### Step 4: T30 Torx Bit Socket & Ratchet

Remove the four bolts securing the lock carrier to the chassis, there are two on each side.

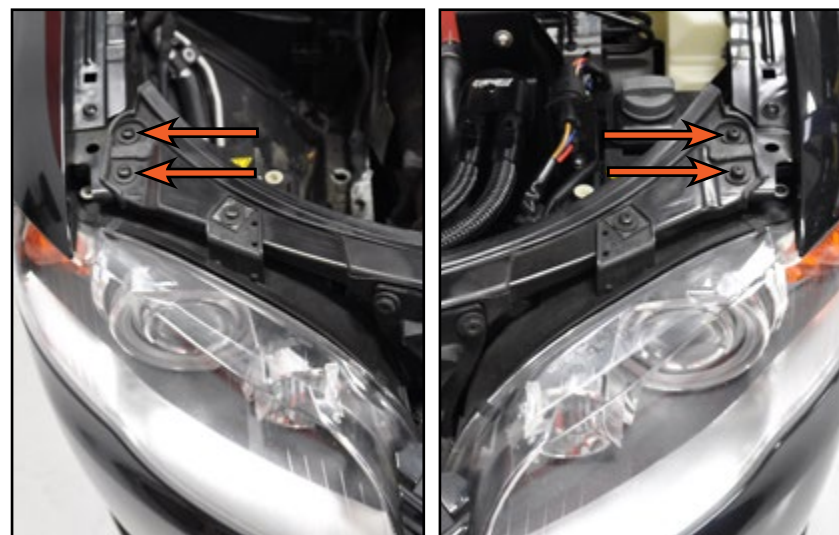

## FRONT LOCK CARRIER - SERVICE POSITION

### Step 5: T30 Torx Bit Socket & Ratchet

Remove the three bolts which secure the top of front bumper cover to the vehicle (**ORANGE** arrows), then loosen but do not remove the two bolts inside the bumper cover (**YELLOW** arrows).



### Step 6: Flat Blade Screwdriver

Safely lift and support the vehicle, then remove the ten (10) 1/4 turn screws and remove the belly pan from the vehicle.

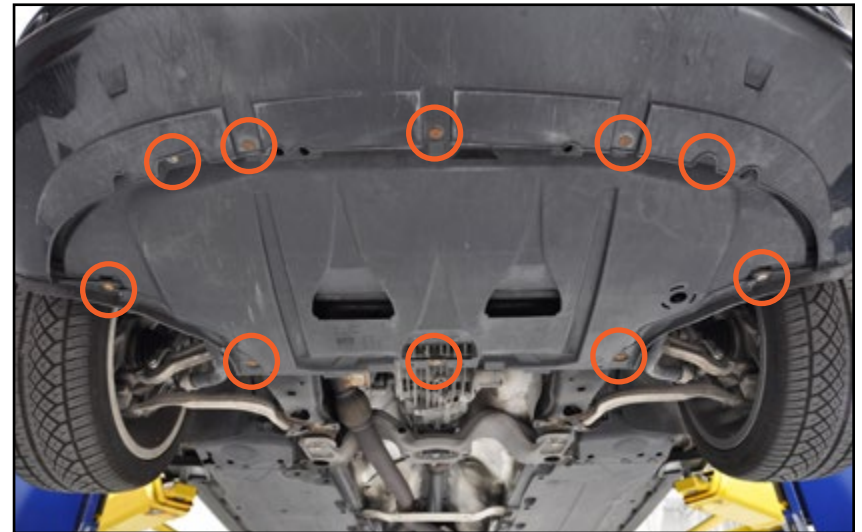

## FRONT LOCK CARRIER - SERVICE POSITION

### Step 7: T25 Torx Bit Socket & Ratchet

Remove the two screws securing the fender liner to the bumper cover on each side of the vehicle.



### Step 8: T25 Torx Bit Socket & Ratchet

Gently pull the fender liner out of the way with one hand while removing the two remaining screws on the inside, repeat this on the other side of the vehicle.



## FRONT LOCK CARRIER - SERVICE POSITION

### Step 9:

Remove the fog lamp grille by grasping the bottom of the grille and pulling it outwards as shown in the photo.



### Step 10: T20 Torx Bit Socket & Ratchet

Remove the three screws securing the fog lamp to the bumper cover, then disconnect the fog lamp connector by releasing the tab and sliding the connector off of the lamp.



## FRONT LOCK CARRIER - SERVICE POSITION

### Step 11: 10mm Socket & Ratchet

Pull the fender liner back in order to access and remove the four nuts which secure the front bumper cover to the fender. Reference the photo shown on the right for the location of the nuts.

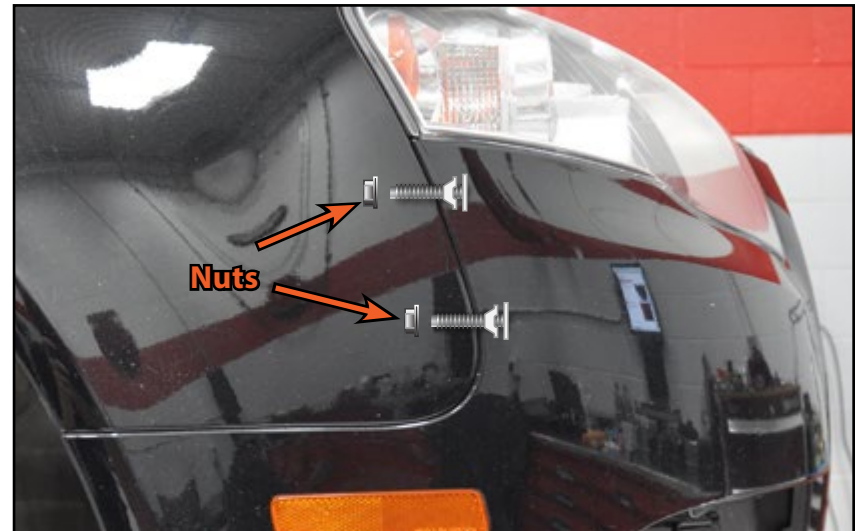

### Step 12:

Enlist the help of a friend, then gently pull outwards on each side of the bumper cover as shown to release the locking tabs (#1). Once both sides of the bumper cover have been released, pull the bumper cover forward slowly approximately three to six inches, using extreme caution to not damage on any connectors which may still be attached.

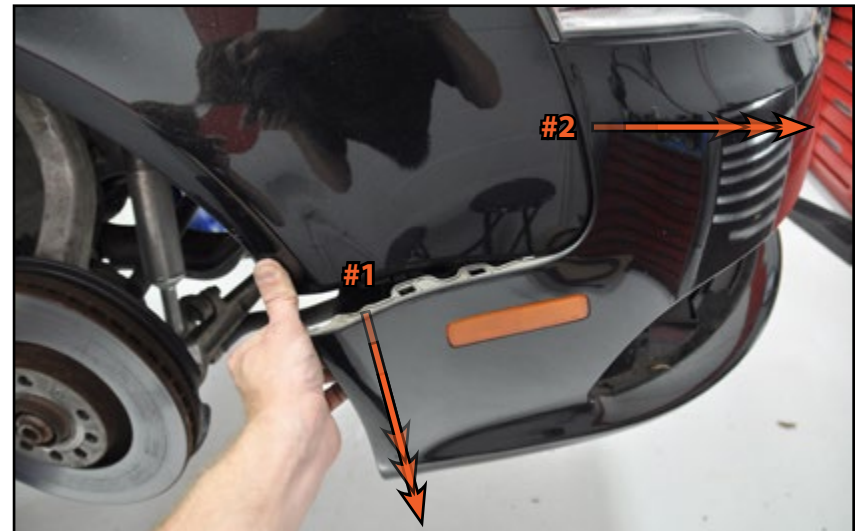

**NOTE**

The bumper cover is NOT completely removed during this step, please continue to [step 13](#) to remove it from the vehicle.

## FRONT LOCK CARRIER - SERVICE POSITION

### Step 13: VAG Connector Tool, Small Flat Blade Screwdriver

Disconnect the two wiring harness connectors in the Front LH of the bumper cover, and disconnect the headlight washer hose if your vehicle is equipped with that option. Remove the bumper cover from the vehicle and set it aside.



For tips on using the VAG Connector Tool, please refer to [Page 45](#) for detailed photos and procedures.

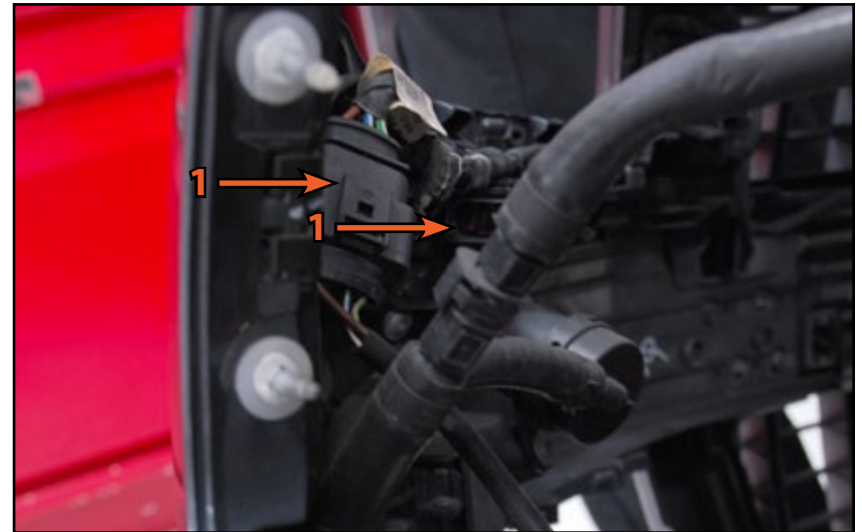

### Step 14: VAG Connector Tool

Disconnect the fan harnesses located on the LH of the engine compartment.





## FRONT LOCK CARRIER - SERVICE POSITION

### Step 15: M10 Triple Square Socket, Ratchet, VAG Connector Tool

Disconnect the electrical connector on each horn, then remove the bolts which secure the front bumper to the bumper support. Remove the bumper from the vehicle and set it aside.

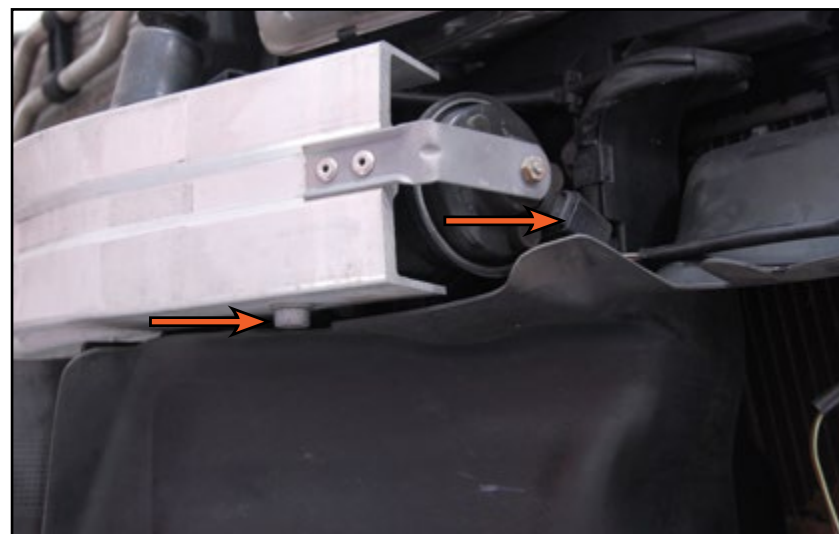

### Step 16: T30 Torx Bit Socket & Ratchet

Remove the bolt securing each front fender to the lock carrier.



## FRONT LOCK CARRIER - SERVICE POSITION

### Step 17: 10mm & 13mm Sockets, Ratchet

Remove the two bolts and one nut from the front bumper support as shown in the photo, DO NOT remove the remaining bolt at this time. Repeat this on the other side of the vehicle.

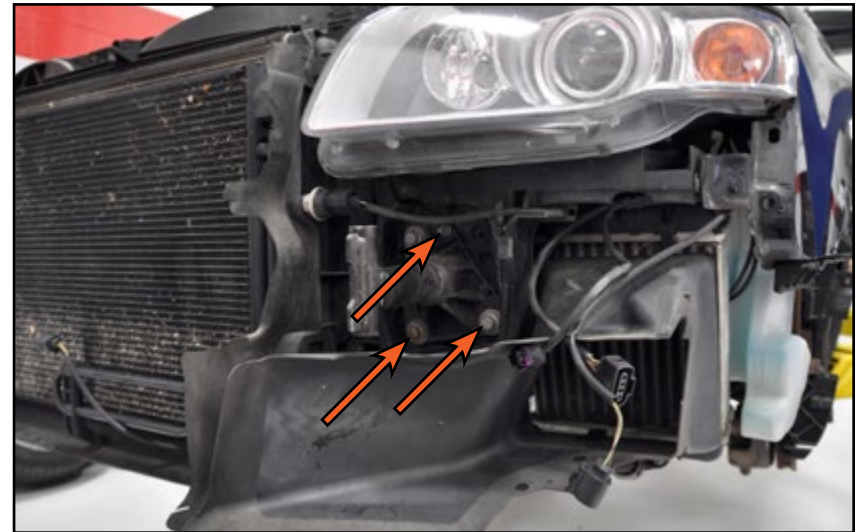

### Step 18: Lock Carrier Tool, 13mm Socket & Ratchet

Install a lock carrier tool into the bolt location as shown in the photo **(1)**, repeat this on the other side of the vehicle. You can now remove the last bolt securing the bumper support **(2)** and remove it from the vehicle.

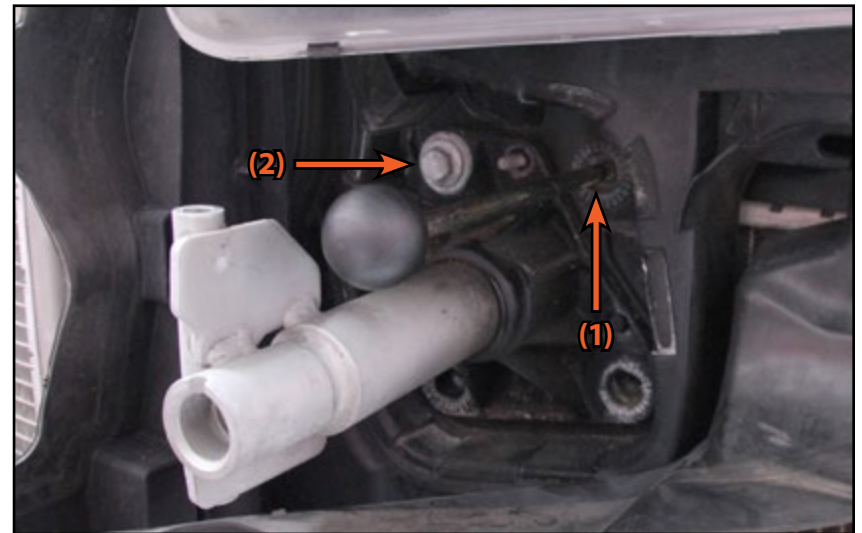

## FRONT LOCK CARRIER - SERVICE POSITION

### Step 19:

Pull the lock carrier forward approximately two inches, anything more than that will risk damaging wiring harnesses and hoses to the front end components.

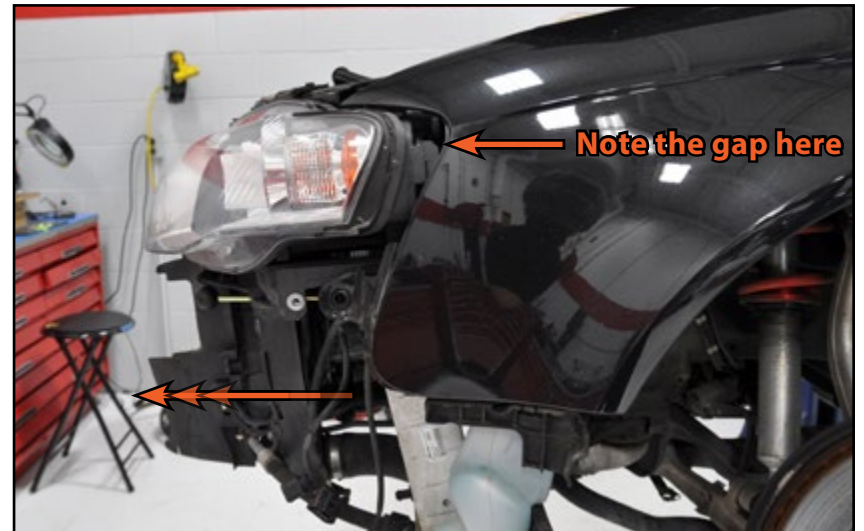

### Step 20: T30 Torx Bit Socket & Ratchet

You can secure the lock carrier in place by loosely reinstalling one of the bolts into the outer hole as shown in the photo. This will prevent the lock carrier from being able to shift while performing any repairs or service.



## REMOVING THE ORIGINAL TIMING BELT

### Step 1:

Remove the coolant reservoir cap, then place a large drain pan underneath the front LH corner of the vehicle.

#### CAUTION

Allow the engine to completely cool **BEFORE** performing this step, this will eliminate the risk of burns to the skin.



### Step 2:

Pliers

Working from underneath the vehicle, loosen the drain valve on the lower LH corner of the radiator by rotating it counter clockwise, then allow the coolant to drain into the drain pan.

#### NOTE

We recommend that you close the drain valve once the coolant has been drained, this will eliminate the risk of forgetting to close it later.



## REMOVING THE ORIGINAL TIMING BELT

### Step 3: 17mm Combination Wrench

Using an open end wrench to engage the tensioner as shown in the photo, rotate the accessory belt tensioner clockwise until the tension has been released on the belt, remove the belt from the engine, then gently allow the tensioner to rotate back to its rest position (DO NOT let the tensioner snap back).

#### TECH TIP

Please refer to the full size diagram of the accessory belt which is located on [Page 8](#).

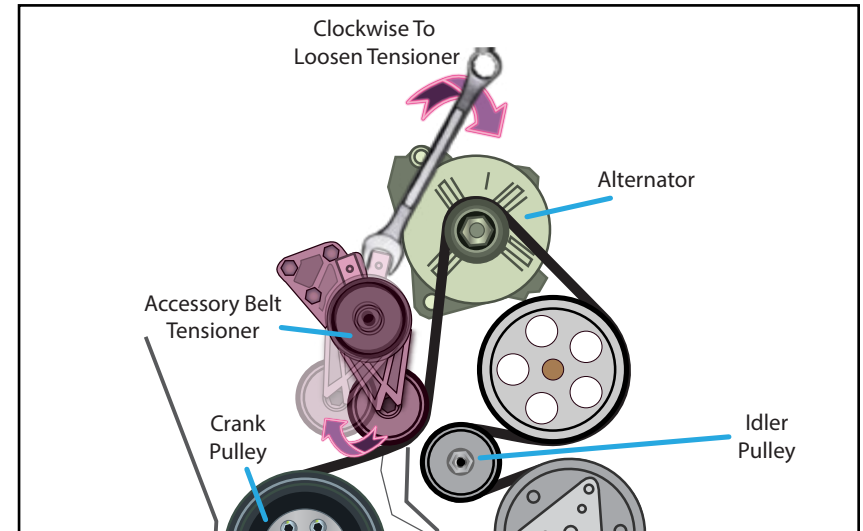

### Step 4: 13mm Socket & Ratchet

Loosen and remove the three bolts which secure the accessory belt tensioner to the engine, then lift the tensioner out of the engine compartment and set it aside.

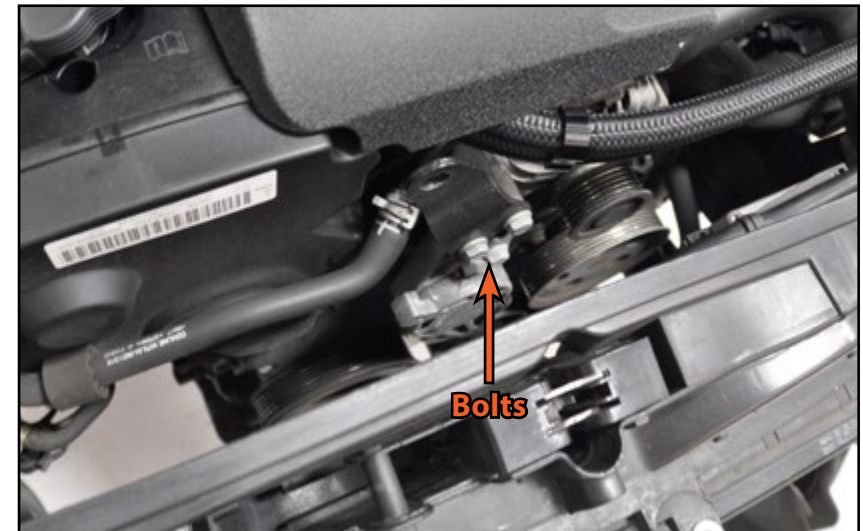

## REMOVING THE ORIGINAL TIMING BELT

### Step 5: Locking Hose Clamp Pliers

Locate the coolant hose in front of the timing cover. Loosen the hose clamp and slide it down the hose approximately two inches.

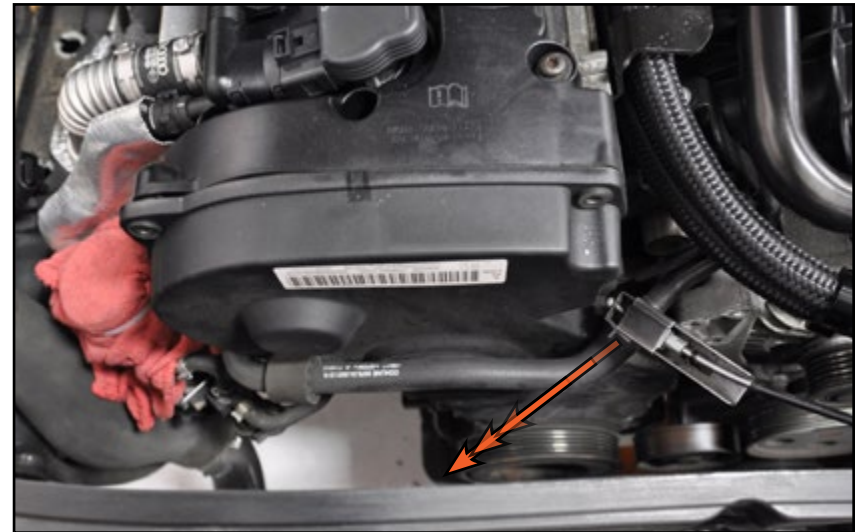

### Step 6:

Remove the hose by twisting and pulling it as shown in the left photo, then secure the hose off to the side with a zip-tie.

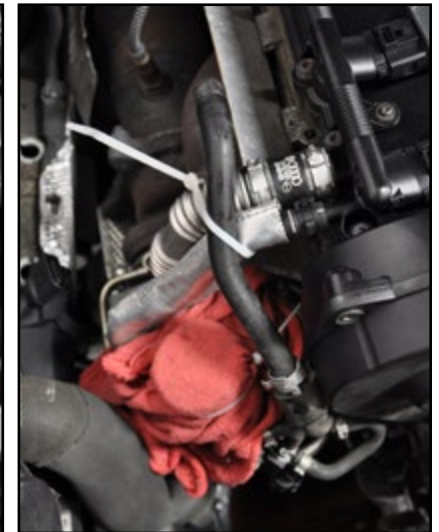
**NOTE**

Some coolant will drain from the hose during removal, tying the hose off to the side should minimize the spill.

## REMOVING THE ORIGINAL TIMING BELT

### Step 7: T30 Torx Bit Socket & Ratchet

Loosen and remove the two bolts which secure the upper timing cover to the engine.

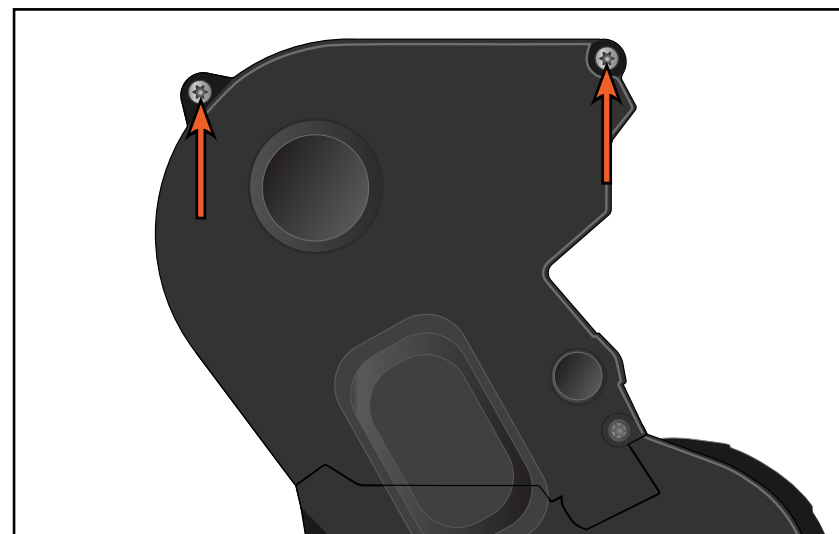

### Step 8:

Pull the upper timing cover toward the radiator, then lift the timing cover upwards and out of the engine compartment.



## REMOVING THE ORIGINAL TIMING BELT

### Step 9: T20 Torx Bit Socket & Ratchet, VAG Connector Tool

Loosen and remove the two screws which secure the ignition coil wiring harness to the top of the valve cover, then disconnect the electrical connectors from each coil and swing the harness out of the way.



### Step 10: Ignition Coil Puller Kit, Spark Plug Socket & Ratchet

Gently pull upwards on the four ignition coils and remove them from the engine, then loosen and remove all four spark plugs.

#### TECH TIP

Inspect the spark plug tubes for any signs of oil or dirt BEFORE removing the spark plugs, then blow out any contaminants with compressed air.

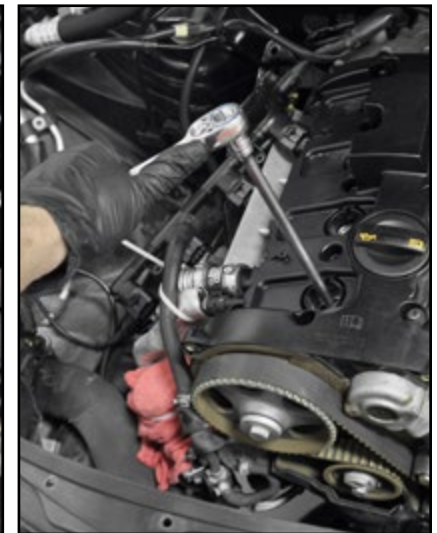



## REMOVING THE ORIGINAL TIMING BELT

### Step 11: 19mm Twelve Point Socket & Ratchet

Using a socket and ratchet on the **CRANKSHAFT BOLT**, rotate the crankshaft **CLOCKWISE** until the camshaft and crankshaft timing marks are **BOTH** aligned, this tells us that the piston in cylinder #1 is at "Top Dead Center" (TDC). Please refer to the diagram shown on the right for a detailed layout of the timing belt and timing marks.

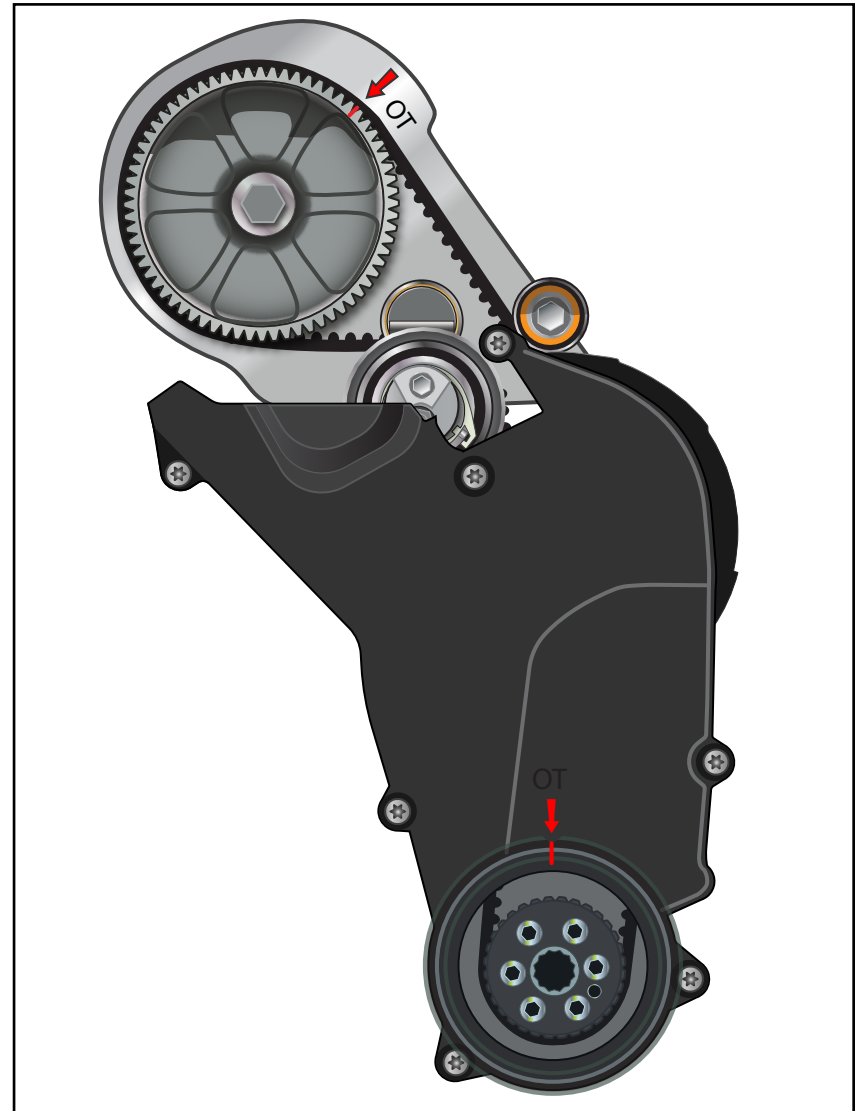

## REMOVING THE ORIGINAL TIMING BELT

### Step 12: Large Flat Blade Screwdriver

Enlist the help of a friend, have that friend insert a screwdriver through the access hole located where the transmission meets the engine, and use the blade of the screwdriver to hold the flywheel in place.



### Step 13: M10 Triple Square/6mm Allen Bit Socket & Ratchet

While the flywheel is being held, loosen but DO NOT remove the bolts which secure the crank pulley to the crankshaft. Once all six bolts are loose, double check your cam and crank timing marks to ensure the engine is still at #1 TDC. Once the timing marks are confirmed to be aligned, remove the crank pulley bolts, then remove the crank pulley by wiggling it back and forth while pulling it off the end of the crankshaft.

#### TECH TIP

Depending on your vehicles manufacturing date these bolts may be M10 Triple Square or 6mm Allen, use a mirror and a flashlight in order to determine which tool is required for your application.



## REMOVING THE ORIGINAL TIMING BELT

### Step 14: T30 Torx Bit Socket & Ratchet

Loosen and remove the seven bolts which secure the lower timing cover to the engine, then remove the lower timing cover from the vehicle.

#### TECH TIP

The bolts in the lower timing cover are slightly shorter than the two we removed from the upper timing cover. Do not mix up these bolts.

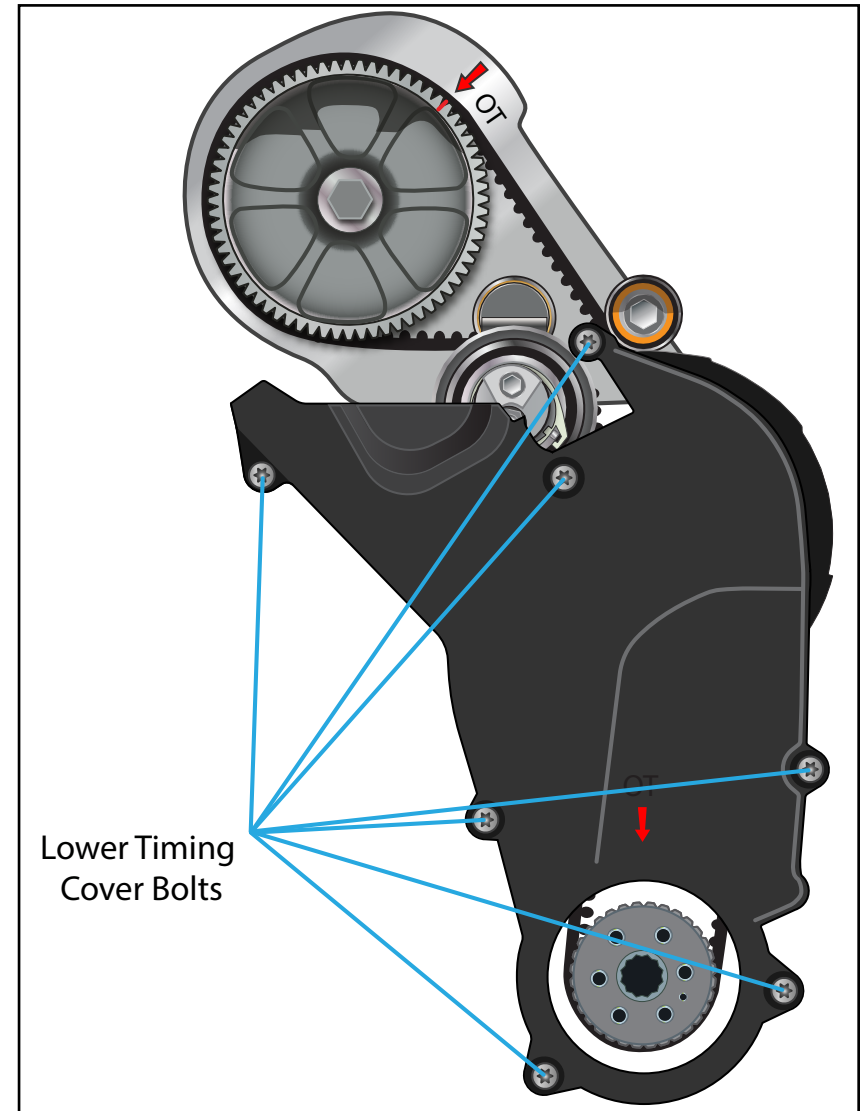

## REMOVING THE ORIGINAL TIMING BELT

### Step 15: Paint Marker

Since we have removed the lower timing cover, we no longer have a timing mark to reference for the crankshaft. After ensuring that the camshaft timing mark is lined up, paint a small line on the engine block and the crankshaft gear. This paint line will be our new crankshaft timing mark until the lower timing cover is reinstalled.



### Step 16: 8mm Allen Wrench & 13mm Combination Wrench

Release the tension from the timing belt tensioner in the following order:

1. Place an 8mm Allen Wrench into the tensioner assembly.
2. Slightly loosen the tensioner assembly nut with a 13mm Wrench.
3. Rotate the tensioner assembly counter clockwise with the Allen Wrench in order to release the tension.

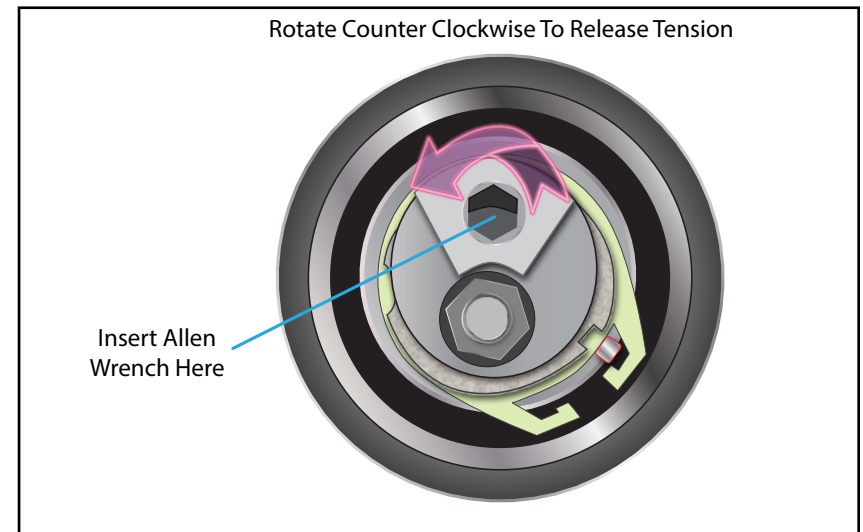

## REMOVING THE ORIGINAL TIMING BELT

### Step 17:

Remove the timing belt components in the following order:

Remove the tensioner assembly (13mm Wrench).

Remove the timing belt.

Remove the upper and lower idler pulleys (12mm & 13mm Sockets, Ratchet).

Remove the water pump bolts (10mm Socket & Ratchet).

Remove the water pump from the engine block.

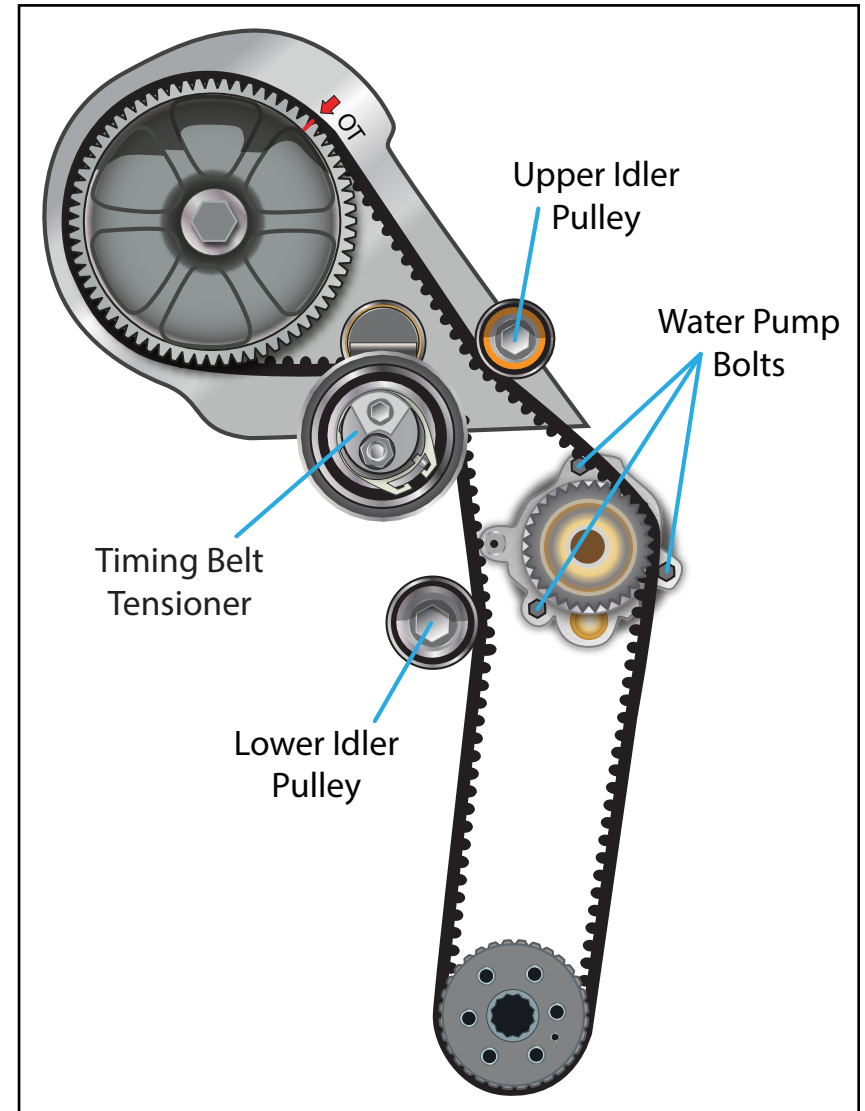

## REPLACING THE CAMSHAFT SEAL

### Step 1: Camshaft Puller Kit

Both the “Ultimate” and the “Ultimate Plus” Timing Belt Kits from ECS Tuning come with a replacement camshaft seal included in the kit. The camshaft seal is a very well known source of oil leaks. We would recommend that you inspect your engine for any signs of leakage from this seal, and if you find any signs of a leak you should replace this seal. If no evidence of a leak can be found, and you choose to not install the seal please skip to [Page 33](#). Replacing the camshaft seal is not an easy task and if the seal isn’t leaking it might be best to leave it as it is.

The photo on the right shows the camshaft puller kit which is required in order to remove the camshaft gear from the camshaft. Please be sure to purchase or rent this tool before attempting this install.



### Step 2: Camshaft Locking Tool Kit, 16mm Socket & Ratchet

Begin by inserting the camshaft locking tool into the camshaft gear, then hold the camshaft in place with the locking tool while you loosen and remove the camshaft gear bolt.

#### CAUTION

DO NOT rotate the camshaft during this process, or valve damage may occur.

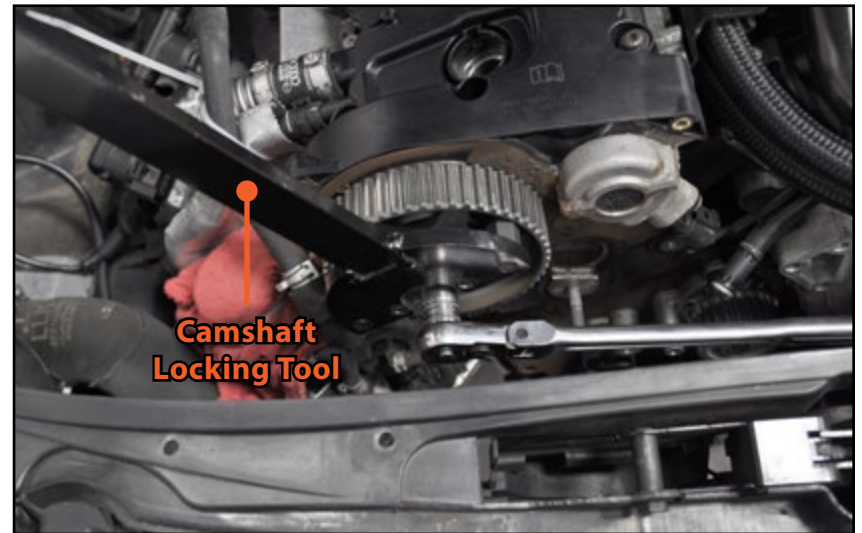

## REPLACING THE CAMSHAFT SEAL

### Step 3: Camshaft Gear Puller Kit

Install the camshaft puller T40001 onto the camshaft gear using claw numbers T40001/7 and T40001/6. Thread the bolt inwards to apply pressure against the camshaft in order to remove the gear.

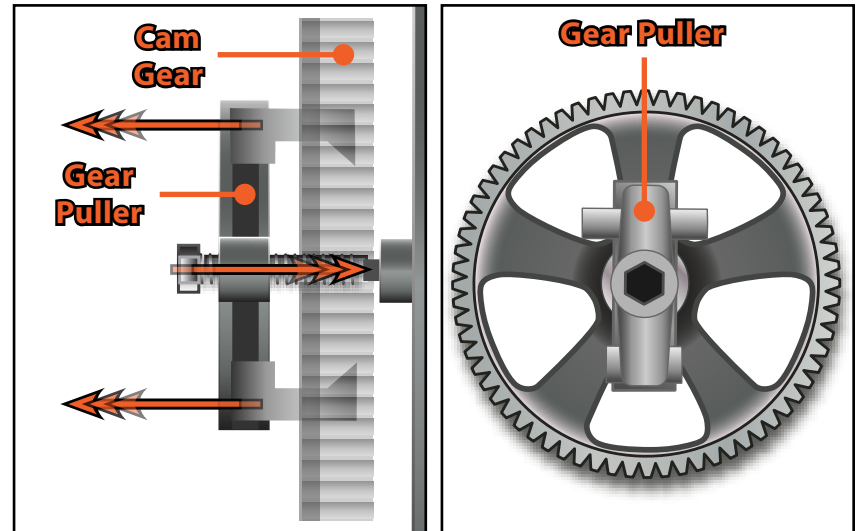

### Step 4: Seal Puller

Carefully remove the camshaft seal from the engine, use extreme caution to prevent damaging/scratching the surface of the camshaft where the seal rides. Clean the sealing surface of the camshaft with a lint free towel and a mild cleaner.

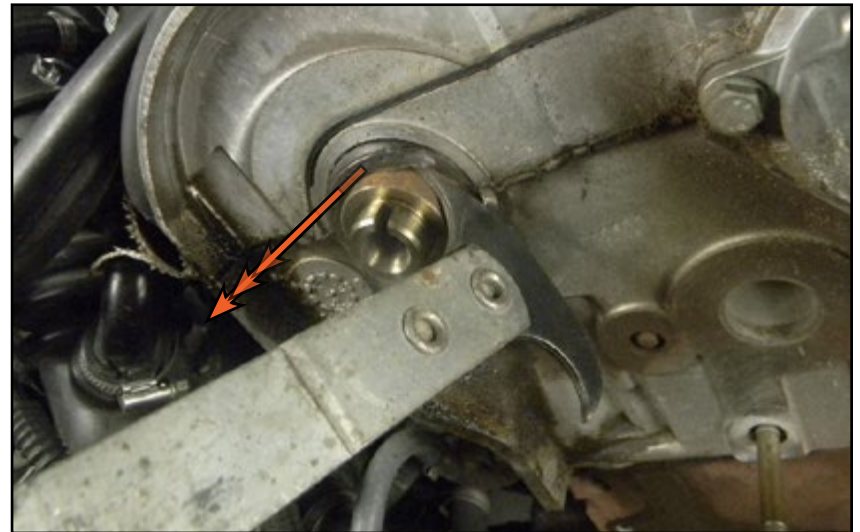

## REPLACING THE CAMSHAFT SEAL

### Step 5: Seal Driver/Large Socket & Hammer

Install the new camshaft seal into the engine with a seal driver, ensuring that the seal is seated evenly and completely. If a seal driver is not available, a socket can be used (right photo) as long as the diameter is large enough to apply even pressure all around the seal, and **WILL NOT** contact or damage the camshaft as the seal is installed.



### Step 6: Camshaft Locking Tool Kit, 16mm Socket & Torque Wrench

Install the camshaft gear onto the camshaft. Insert the camshaft locking tool into the camshaft gear, then hold the camshaft in place with the locking tool while you torque the bolt to 50 Nm (36.9 Ft-lbs) + 180 Degrees.





## INSTALLING THE NEW TIMING BELT

### Step 1:

Thoroughly clean the water pump gasket surface on the engine block, including the beveled edge where the water pump o-ring sits.

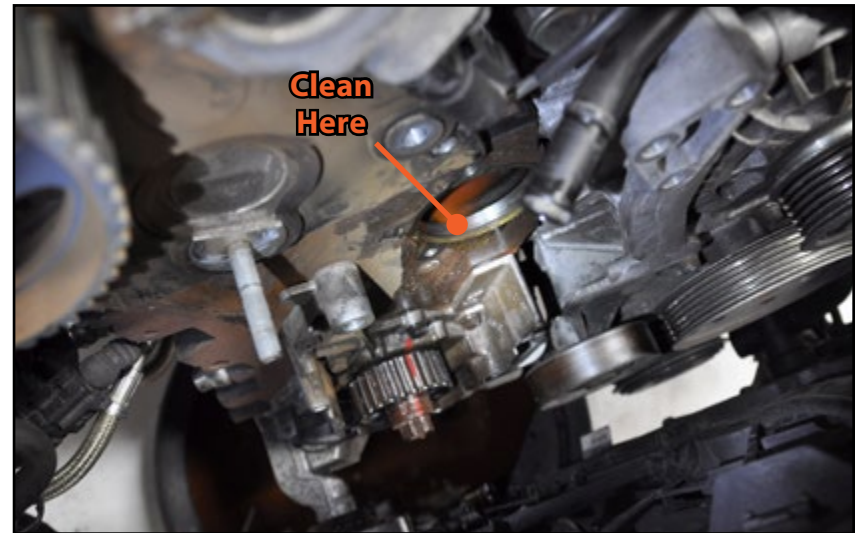

### Step 2: 10mm Socket & Torque Wrench

Lubricate the water pump o-ring seal with a small amount of fresh coolant, then install the water pump by inserting it into the engine block. Torque the water pump bolts to 15 Nm (11 Ft-lbs).



## INSTALLING THE NEW TIMING BELT

### Step 3: 12mm/13mm Sockets & Torque Wrench

Install the upper idler pulley (INA part: [ES#252399](#)) with the bolt included in the kit, then install the lower idler pulley (NTN part: [ES#3958](#)) as shown in the photo to the right, then torque them as follows:

- Upper Idler Pulley - 25 Nm (18.4 Ft-lbs)
- Lower Idler Pulley - 35 Nm (25.8 Ft-lbs)

#### NOTE

The lower timing belt idler pulley comes with a new bolt already installed. DO NOT mix up these two pulleys during installation.

### Step 4:

Ensure that the camshaft and crankshaft timing marks are lined up, then install the timing belt onto the engine using the diagram on [Page 9](#) as a reference. Slide the timing belt tensioner partially onto the stud as shown in the photo, then please continue to [step 5](#) **BEFORE** installing/tightening the timing belt tensioner washer and nut:

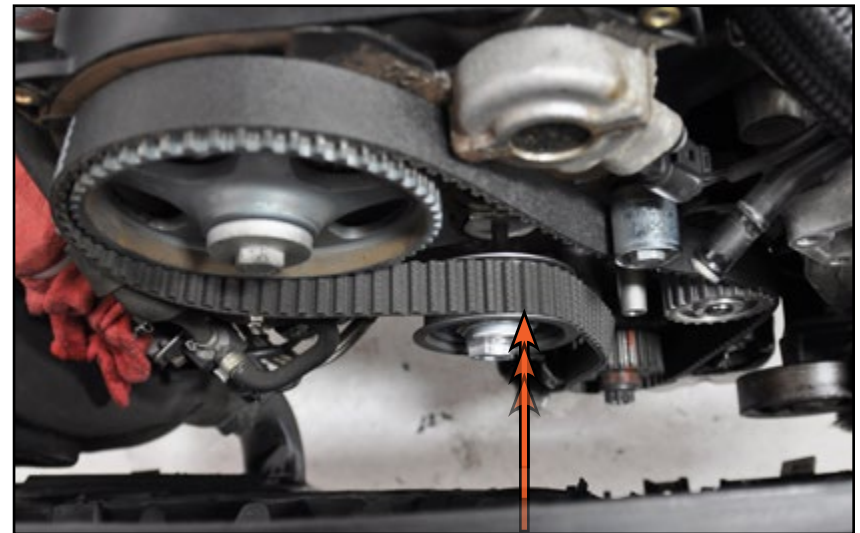
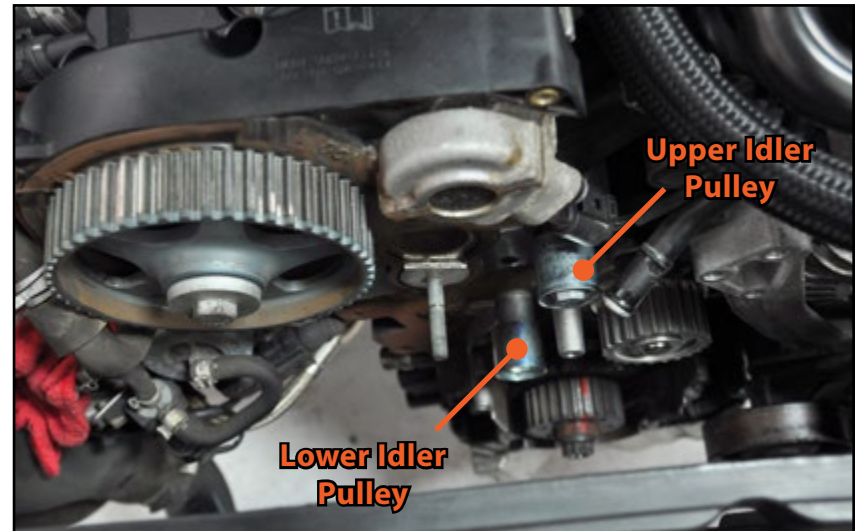

## INSTALLING THE NEW TIMING BELT

### Step 5:

It is **EXTREMELY** important that the locking tab on the back of the tensioner assembly is inserted into the freeze plug located on the front of the cylinder head. **DO NOT** attempt to tighten the timing belt tensioner into place until the locking tab is in position as shown in the photo, or damage to the tensioner will likely occur, and you will be unable to apply the necessary tension onto the timing belt.

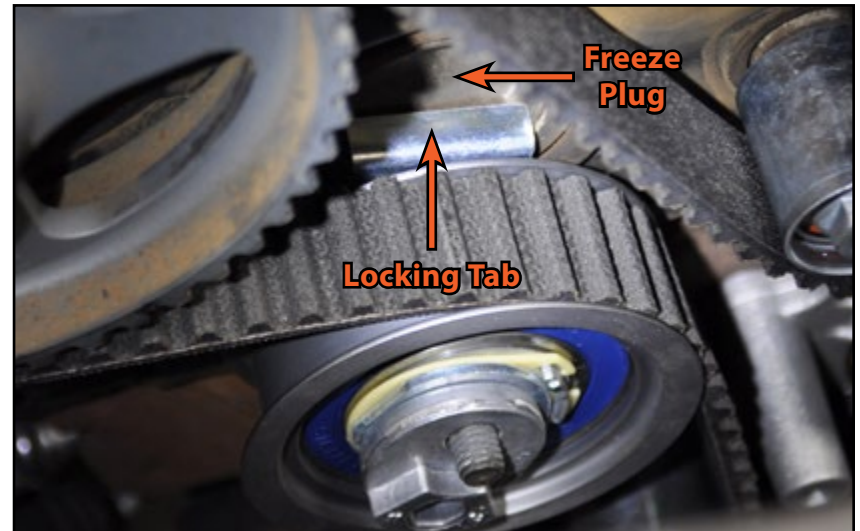

### Step 6: 8mm Allen Wrench, 13mm Socket & Torque Wrench

Apply tension to the timing belt tensioner in the following order:

1. Place an 8mm Allen Wrench into the tensioner assembly.
2. Install the new nut and washer which are included in the kit onto the tensioner assembly.
3. **SLIGHTLY** tighten the tensioner assembly nut, it must be loose enough to allow the tensioner to rotate while applying tension, but tight enough to prevent the tensioner from snapping back once it is in position.
4. Rotate the tensioner assembly clockwise with the Allen Wrench until the alignment tab is in line with the notch in the tensioner as shown in the diagram on the right.
5. Torque the tensioner nut to 25 Nm (18.4 Ft-lbs).

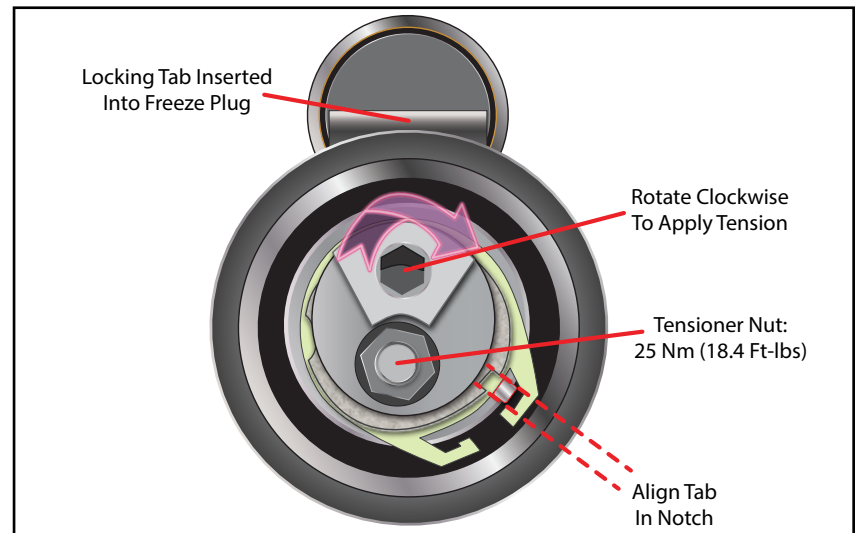

## INSTALLING THE NEW TIMING BELT

### Step 7: 19mm Twelve Point Socket & Ratchet

Once the tensioner has been installed and tightened, check that the camshaft and crankshaft timing marks are lined up.

If the timing marks **ARE NOT** both lined up, release the tension from the tensioner, remove the timing belt and reinstall. In some cases it may be necessary to rotate the crankshaft so that it is **ONE TOOTH CLOCKWISE** past the timing mark, it will then rotate back into the correct position when the timing belt tensioner is installed and tightened.

If the timing marks **ARE** both lined up, **SLOWLY** rotate the engine **CLOCKWISE** (with a socket and ratchet on the **CRANKSHAFT BOLT**) **TWO FULL REVOLUTIONS** (four 360 degree turns of the crankshaft), then check the timing marks again. If the timing marks are lined up, continue to [step 8](#), if they do not line up, repeat this step.

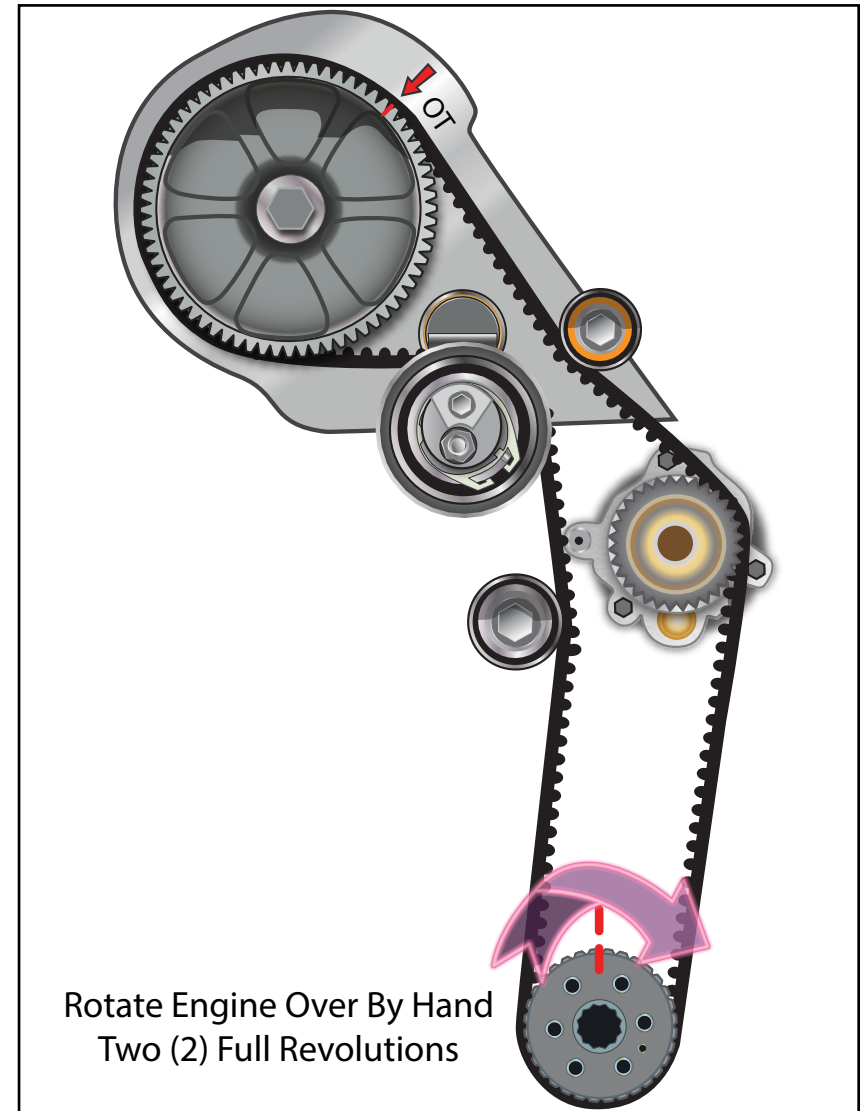

## INSTALLING THE NEW TIMING BELT

### Step 8: T30 Torx Bit Socket & Torque Wrench

Install the seven (7) bolts which secure the lower timing belt cover to the engine, then torque them to 10 Nm (7.4 Ft-lbs).

#### TECH TIP

The bolts in the lower timing cover are slightly shorter than the two we removed from the upper timing cover, do not mix up these bolts.

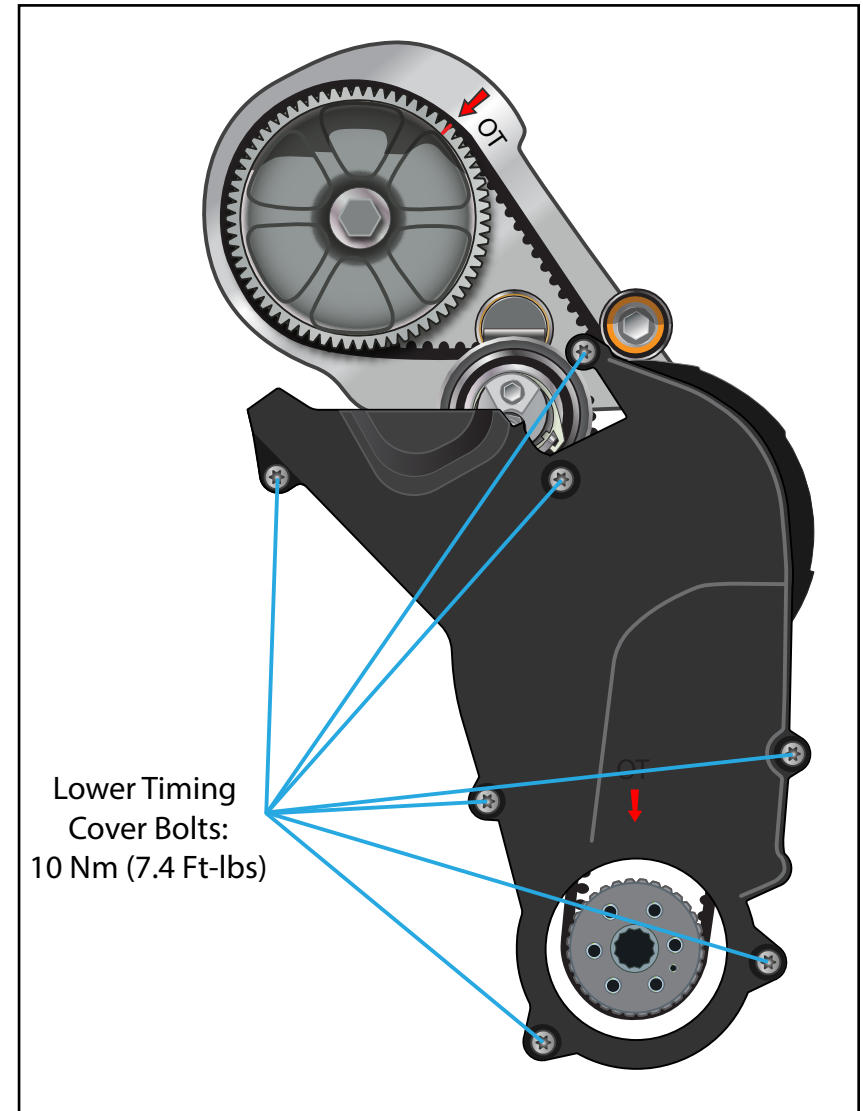

## INSTALLING THE NEW TIMING BELT

### Step 9:

Locate and identify the locating bump on the end of the crankshaft (left photo) and the corresponding locating hole in the crankshaft pulley (right photo). Install the crankshaft pulley onto the crankshaft, ensuring that all six mounting bolt holes are lined up, and that the locating bump is inside the locating hole in the pulley.

#### NOTE

This process is the same whether you are installing the original crank pulley or the ECS Tuning Lightweight Underdrive Crank Pulley.



### Step 10: 6mm Allen Bit Socket & Torque Wrench

Hand tighten all six mounting bolts in the crankshaft pulley, then confirm that the timing mark lines up with the mark on the timing cover (left photo), and confirm that the camshaft timing marks are lined up as well.

Once the timing marks are confirmed to be lined up correctly, hold the flywheel in place in the same manner as when we removed the crank pulley, then install the six included crankshaft pulley bolts and torque them to 10 Nm + 90 Degrees.



## INSTALLING THE NEW TIMING BELT

### Step 11:

Locate and identify the groove which is located on the top of the lower timing cover (highlighted in **RED** in the photo). Install the upper timing cover into place, ensuring that it is completely seated in the groove in the lower timing cover.



### Step 12: T30 Torx Bit Socket & Torque Wrench

Install and torque the two upper timing cover bolts to 10 Nm (7.4 Ft-lbs).

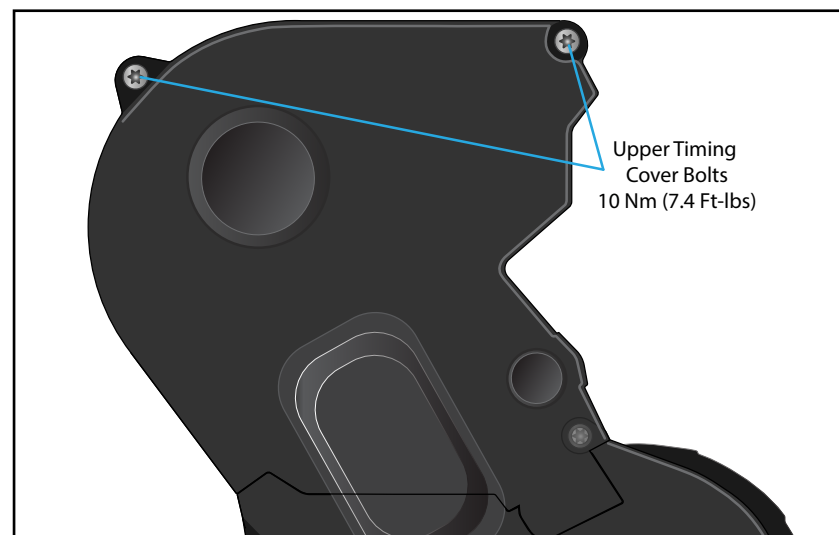

## INSTALLING THE NEW TIMING BELT

### Step 13: Locking Hose Clamp Pliers

Reconnect the coolant hose located in front of the timing cover.



### Step 14: 17mm Combination Wrench, 13mm Socket & Torque Wrench

Reinstall the accessory belt tensioner and torque the tensioner bolts to 23 Nm (17 Ft-lbs). Reinstall the accessory belt, refer to the diagram on [Page 8](#) for belt routing instructions.

Reinstall the spark plugs and ignition coils.

Reinstall the lock carrier in reverse order of removal.

Reinstall the intake duct.

Reinstall the belly pan.





## BLEEDING THE COOLING SYSTEM

### Step 1:

The complexity and component location of these cooling systems causes air to become trapped, which can cause overheating and engine damage. For this reason, bleeding the air from the system is extremely important. The picture on the right shows the air bleed hose for the reservoir and the bleed screw in the upper coolant pipe. During regular cooling system operation, the air bleed hose will allow small amounts of air to rise to the high point of the reservoir, and subsequently be replaced in the system with coolant. It is not able, however, to bleed air quickly enough in a system that has ingested a large amount of air (such as during a repair). Air will naturally rise to the top, but in this system there are two points in which it will become trapped because they are higher than the coolant level in the reservoir; the upper coolant pipe and the heater core inlet.

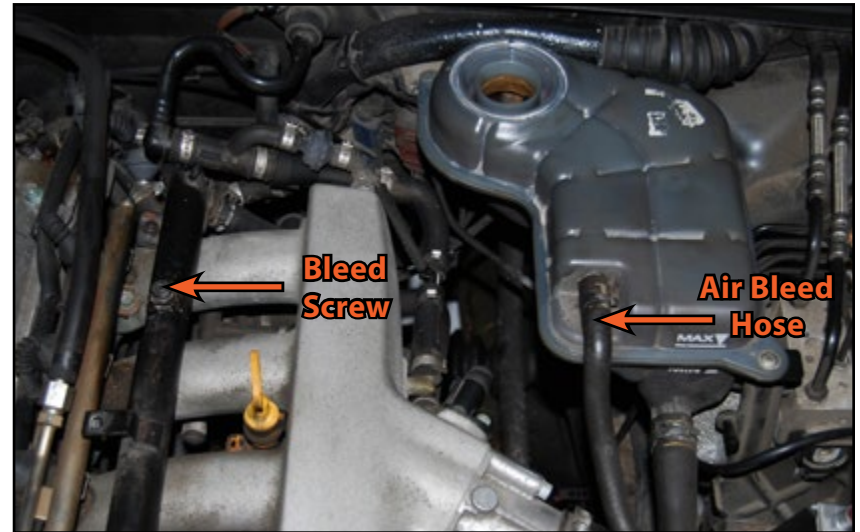

### Step 2:

#### Schwaben Coolant Evacuation Tool Kit

The cooling system must be filled using a 50/50 mix of distilled water and G13 coolant. One method of filling the cooling system is to use our Schwaben Coolant Evacuation Tool Kit. This tool kit uses compressed air to draw a vacuum on the entire cooling system, then that vacuum is used to draw in fresh coolant into the system without any air pockets.

For detailed instructions on how to use this tool, please click [HERE](#).



## BLEEDING THE COOLING SYSTEM

### Step 3:

Loosen the bleed screw on the upper coolant pipe. Fill the reservoir with coolant until a steady stream runs out, then tighten the bleed screw. You will need to keep the reservoir completely full for this to happen.

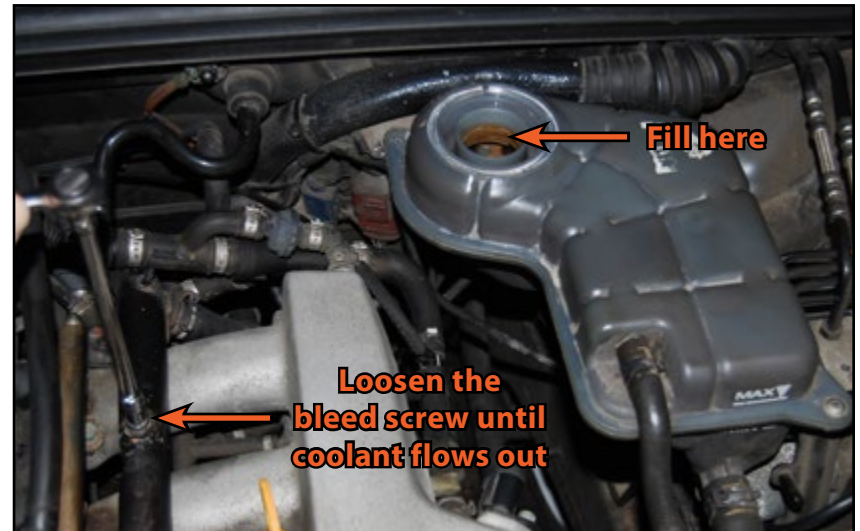

### Step 4:

Here you can see a view of the heater hoses. Removing the cowl seal and gently lifting the cowl panel will give you the best access to them. The upper hose has a small hole in it just forward of the clamp (arrow). This is the highest point in the cooling system.



## BLEEDING THE COOLING SYSTEM

### Step 5:

Using spring clamp pliers, loosen the clamp on the upper heater hose then slide it back far enough so it is not securing the hose to the heater core. Next, slide the heater hose off the heater core just until the bleeder hole is exposed. The end of the hose is long enough so it will remain on the heater core with the bleed hole exposed.

The illustration on the left shows the heater hose in its installed position. Notice that the clamp secures the hose to the heater core in front of the bleed hole so the system is sealed.

The illustration on the right shows the heater hose pulled back so the bleeder hole is unobstructed, allowing air to escape, yet the hose is still pushed over the end of the heater core.

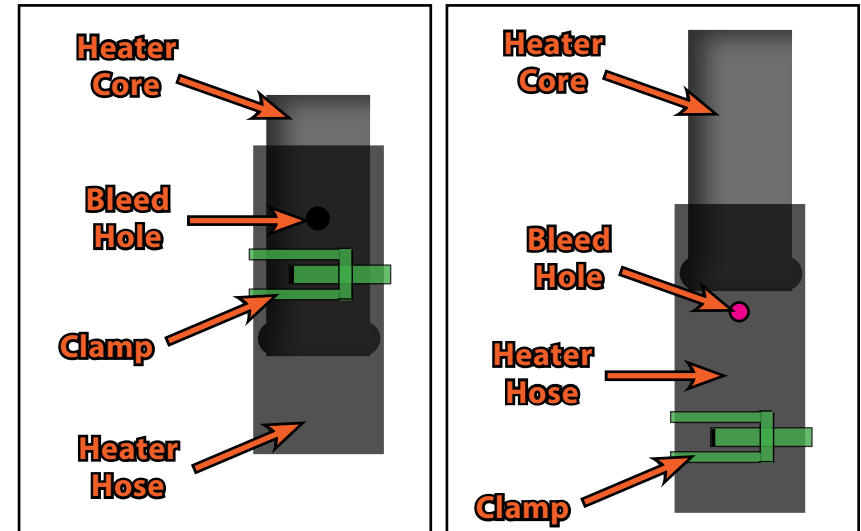

### Step 6:

Fill the coolant reservoir until coolant runs out the hole in the heater hose. Since the opening of the coolant reservoir is lower than the heater hoses, you will need to extend the opening using, for example, an old coolant hose, so the "high point" of the reservoir is higher than the heater hoses. This will force all of the air out of the system. Once coolant flows from the hole in the heater hose, re-install the hose.

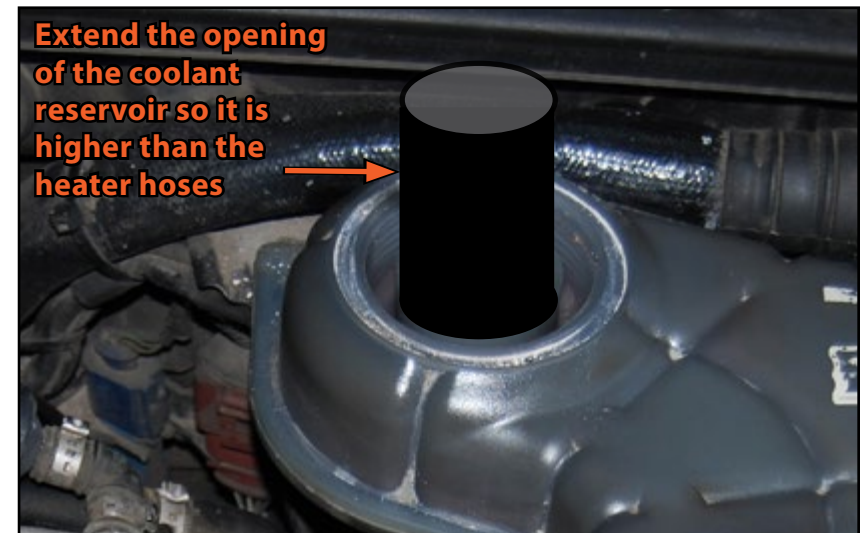

## BLEEDING THE COOLING SYSTEM

### Step 7:

Reinstall the radiator cap, then start the engine and allow it to warm up to operating temperature. Closely inspect the entire system for any coolant leaks.

Remove the coolant reservoir "extension".

Install the coolant reservoir cap.

Start the engine and run it at 2000 RPM for 3 minutes.

Allow the engine to idle until it reaches operating temperature (both the upper and lower radiator hoses will be hot).

Visually inspect the cooling system and check for any leaks.

Shut the engine off and allow it completely cool.

Top off the coolant reservoir.



*Your Audi B7 A4 2.0T Timing Belt Kit installation is complete!*

## USING THE VAG CONNECTOR TOOL

### Step 1:

These connectors are commonly referred to as “Push and Pull” connectors, in reference to the method used to disconnect them.

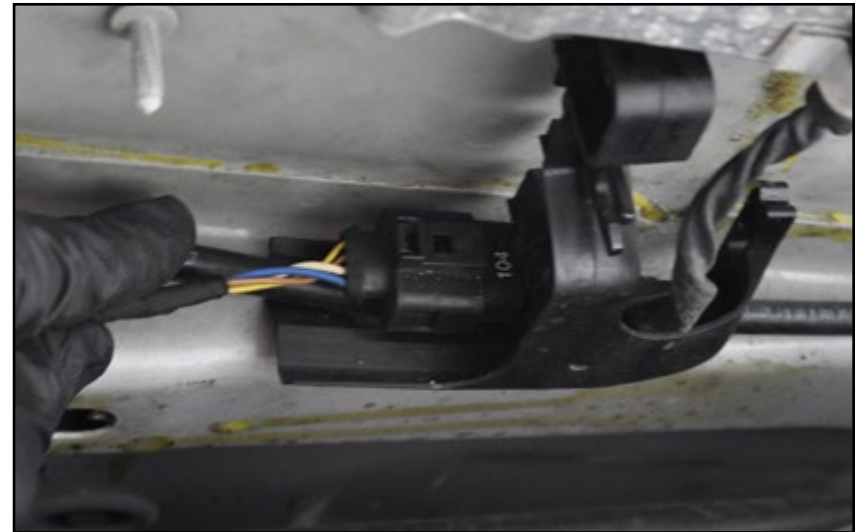

### Step 2:

#### VAG Connector Tool

To disconnect one of these connectors, follow this procedure:

1. Engage the connector release tool into the connector housing.
2. Push inward gently on the connector.
3. While holding pressure inward on the connector, pull up on the handle of the release tool.
4. Pull the connector off of the component.





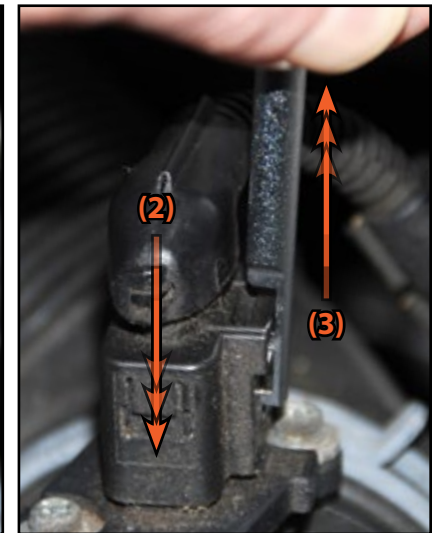
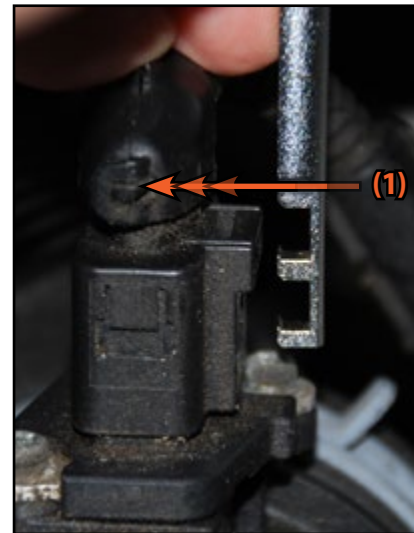















To return to the Lock Carrier Service Position Instructions, simply click [HERE](#).



# SCHWABEN - BUILD THE ULTIMATE TOOL COLLECTION

At ECS Tuning, we carry a line of high quality Schwaben Tools and Equipment to help you build your ultimate tool collection. Never before has affordability and quality been so closely related. Our entire Schwaben line is subjected to strict in house testing for strength and durability. See what we have to offer and equip your garage without breaking the bank.

					
	<a href="#"><u>Breaker Bar</u></a> <a href="#"><u>Creepers</u></a> <a href="#"><u>Gloves</u></a> <a href="#"><u>Engine Bars</u></a> <a href="#"><u>Screwdrivers</u></a> <a href="#"><u>Pressure Bleeders</u></a> <a href="#"><u>Lighting</u></a> <a href="#"><u>Pry Bars</u></a> <a href="#"><u>Coil Spring Compressors</u></a> <a href="#"><u>Camber Gauge</u></a> <a href="#"><u>Hose Pinch Pliers</u></a> <a href="#"><u>Wheel Bolt Pattern Gauge</u></a> <a href="#"><u>Ball Joint Separator</u></a> <a href="#"><u>Vanos Solenoid Socket</u></a>	<a href="#"><u>Scraper, Hook, &amp; Pick Set</u></a> <a href="#"><u>Camshaft Tools</u></a> <a href="#"><u>Fan Clutch Wrenches</u></a> <a href="#"><u>Tie Rod Tools</u></a> <a href="#"><u>Brake Fluid Catch Bottle</u></a> <a href="#"><u>Tube Cutter</u></a> <a href="#"><u>Booster Cables</u></a> <a href="#"><u>Oil Filter Tools</u></a> <a href="#"><u>Service Carts</u></a> <a href="#"><u>Battery Charger</u></a> <a href="#"><u>Stethoscope</u></a> <a href="#"><u>Battery Terminal Brush</u></a> <a href="#"><u>Wheel Chocks</u></a> <a href="#"><u>Torx Sockets</u></a>	<a href="#"><u>Sockets</u></a> <a href="#"><u>E-Drive Sockets</u></a> <a href="#"><u>Car Ramps</u></a> <a href="#"><u>Torx Drivers</u></a> <a href="#"><u>Jack Stands</u></a> <a href="#"><u>Circuit Tester</u></a> <a href="#"><u>Ratchets</u></a> <a href="#"><u>Exhaust Hanger Pliers</u></a> <a href="#"><u>Bubble Flaring Tool</u></a> <a href="#"><u>Thread Chaser</u></a> <a href="#"><u>Drain Pans</u></a> <a href="#"><u>Wrenches</u></a> <a href="#"><u>Impact Sockets</u></a> <a href="#"><u>Torque Wrenches</u></a>		
					
					
					

Your Audi B7 A4 2.0T Timing Belt Kit installation is complete!



**These instructions are provided as a courtesy by ECS Tuning**

Proper service and repair procedures are vital to the safe, reliable operation of all motor vehicles as well as the personal safety of those performing the repairs. Standard safety procedures and precautions (including use of safety goggles and proper tools and equipment) should be followed at all times to eliminate the possibility of personal injury or improper service which could damage the vehicle or compromise its safety.

Although this material has been prepared with the intent to provide reliable information, no warranty (express or implied) is made as to its accuracy or completeness. Neither is any liability assumed for loss or damage resulting from reliance on this material. SPECIFICALLY, NO WARRANTY OF MERCHANTABILITY, FITNESS FOR A PARTICULAR PURPOSE OR ANY OTHER WARRANTY IS MADE OR TO BE IMPLIED WITH RESPECT TO THIS MATERIAL. In no event will ECS Tuning, Incorporated or its affiliates be liable for any damages, direct or indirect, consequential or compensatory, arising out of the use of this material.