

## VW MK5-7 Rear Subframe Locking Collar Kit Installation Instructions - [Click HERE to Shop](#)



## INSTALLATION NOTES

- **RH** refers to the *passenger side* of the vehicle.
- **LH** refers to the *driver side* of the vehicle.
- Always use the proper torque specifications.
- If applicable to this installation, torque specifications will be listed throughout the document and at the end as well.
- Please read all of these instructions and familiarize yourself with the complete process **BEFORE** you begin.

## GENERAL PREPARATION AND SAFETY INFORMATION

ECS Tuning cares about your health and safety, please read the following safety information. This information pertains to automotive service in general, and while it may not pertain to every job you do, please remember and share these important safety tips.

- Park your car in a safe, well lit, level area.
- Shut the engine off and remove the key from the ignition switch.
- Make sure any remote start devices are properly disabled.
- **ALWAYS** wear safety glasses.
- Make sure the parking brake is applied until the vehicle is safely lifted and supported.
- Whether lifting a vehicle using an automotive lift or a hydraulic jack, be sure and utilize the factory specified lift points.
- Lifting a vehicle in an incorrect location can cause damage to the suspension/running gear.
- **ALWAYS** support the vehicle with jack stands.
- **ALWAYS** read and follow all safety information and warnings for the equipment you are using.



**NEVER** get underneath a vehicle that is supported only by a jack, and **ALWAYS** make sure that the vehicle is securely supported on jack stands.



## INSTALLING THE LOCKING COLLAR KIT

### Step 1: 18mm Socket & Ratchet

Safely lift and support the vehicle. If equipped, completely remove the two securing bolts (**YELLOW** inset photo) located just above the sway bar bracket on either side. Gradually loosen the four subframe mounting bolts (arrows) until there is a large enough gap to slide the upper locking collar between the top of the subframe and the underside of the vehicle as shown in the photo below.

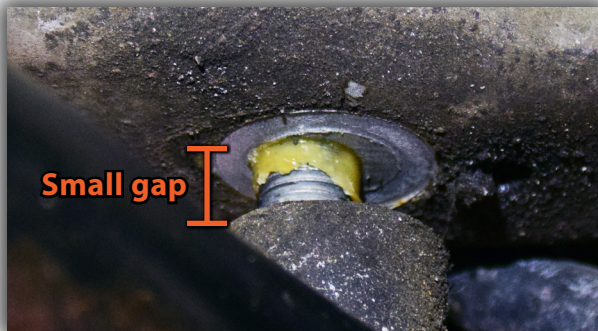

Do not remove the bolts yet, just loosen them enough to gain the required amount of clearance (as shown in the photo above).

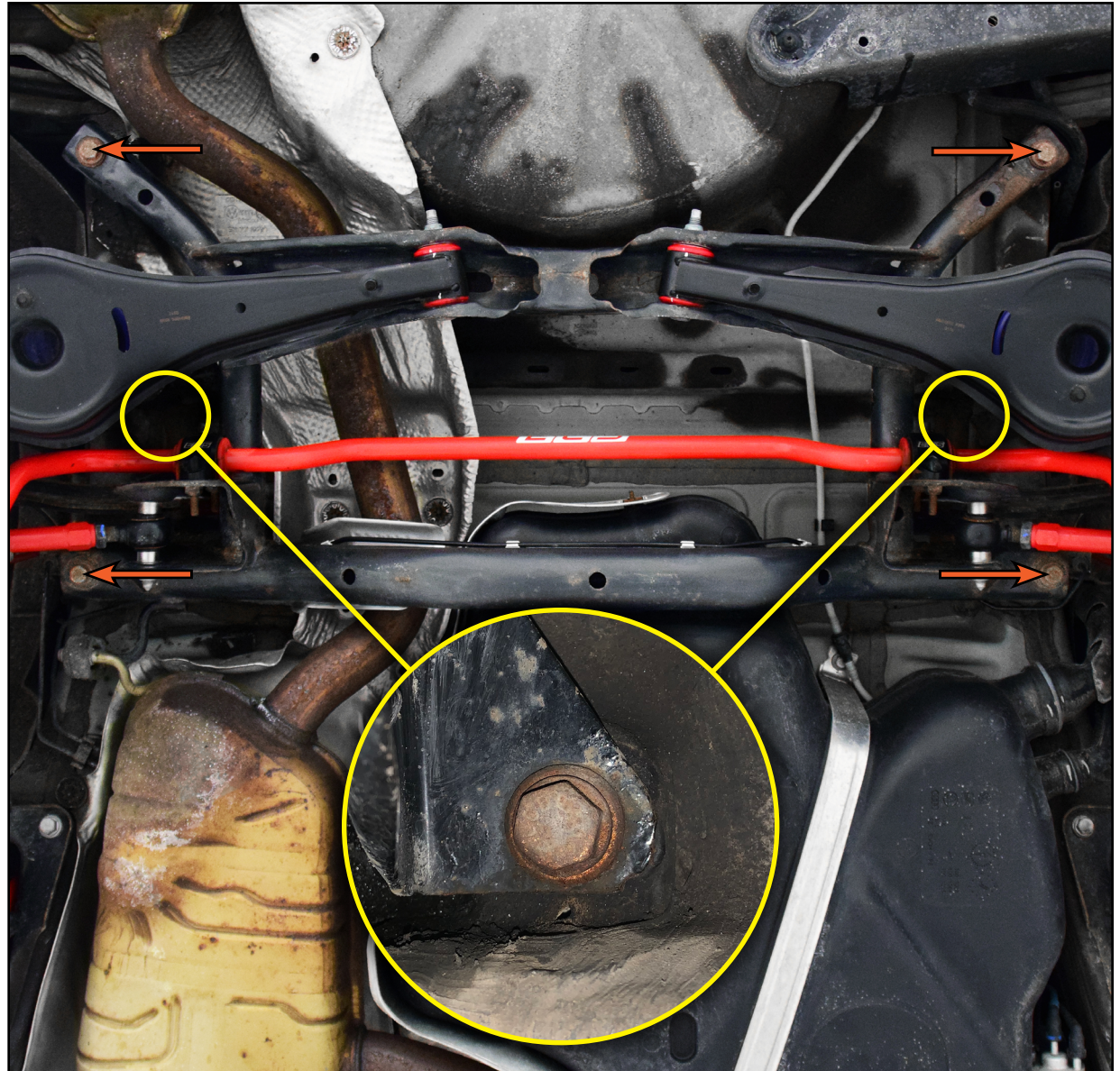



## INSTALLING THE LOCKING COLLAR KIT

### Step 2: 18mm Socket & Ratchet

Remove **ONE** of the four bolts from the subframe.



### Step 3:

Slide the upper collar into place between the subframe and the body, ensuring that the collar is oriented correctly as shown in the illustration on the right.

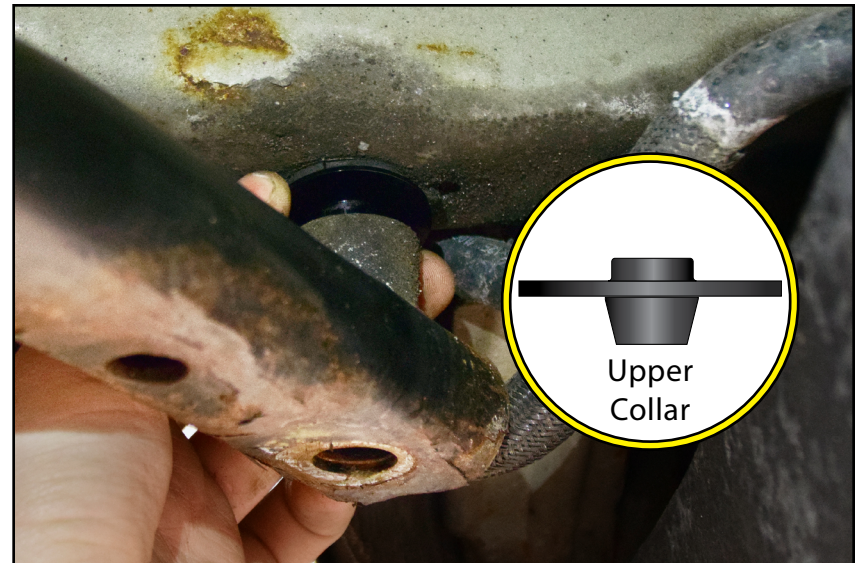



## INSTALLING THE LOCKING COLLAR KIT

### Step 4:

Slide the lower collar onto one of the provided replacement bolts in the orientation shown in the photo and illustration on the right.



Certain vehicles have subframe bolts which differ in length, be sure to replace the bolt you removed with an identical replacement from the kit.

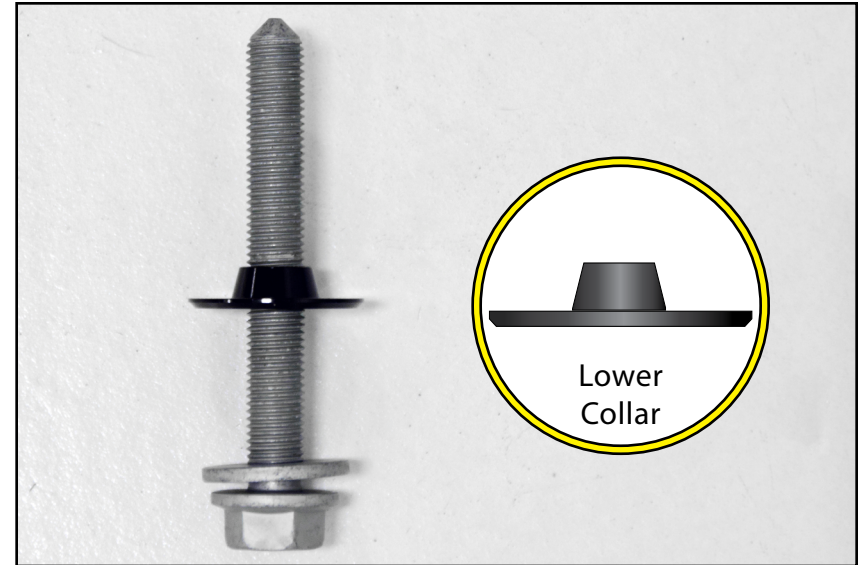

### Step 5: 18mm Socket & Ratchet

Slide the bolt up through the subframe and upper collar and into the body of the vehicle. Thread the bolt into the body until the lower collar contacts the subframe as shown, but leave it loose while we repeat this process for the other three bolts.



## INSTALLING THE LOCKING COLLAR KIT

### Step 6: 18mm Socket & Torque Wrench

Once all the collars have been installed, gradually tighten the four bolts until the subframe is drawn back up into place, then torque the bolts to 70 Nm (52 Ft-lbs) + 180°. If equipped, reinstall the two securing bolts (circled in **YELLOW**) and torque them to 50 Nm (37 Ft-lbs) + 45°

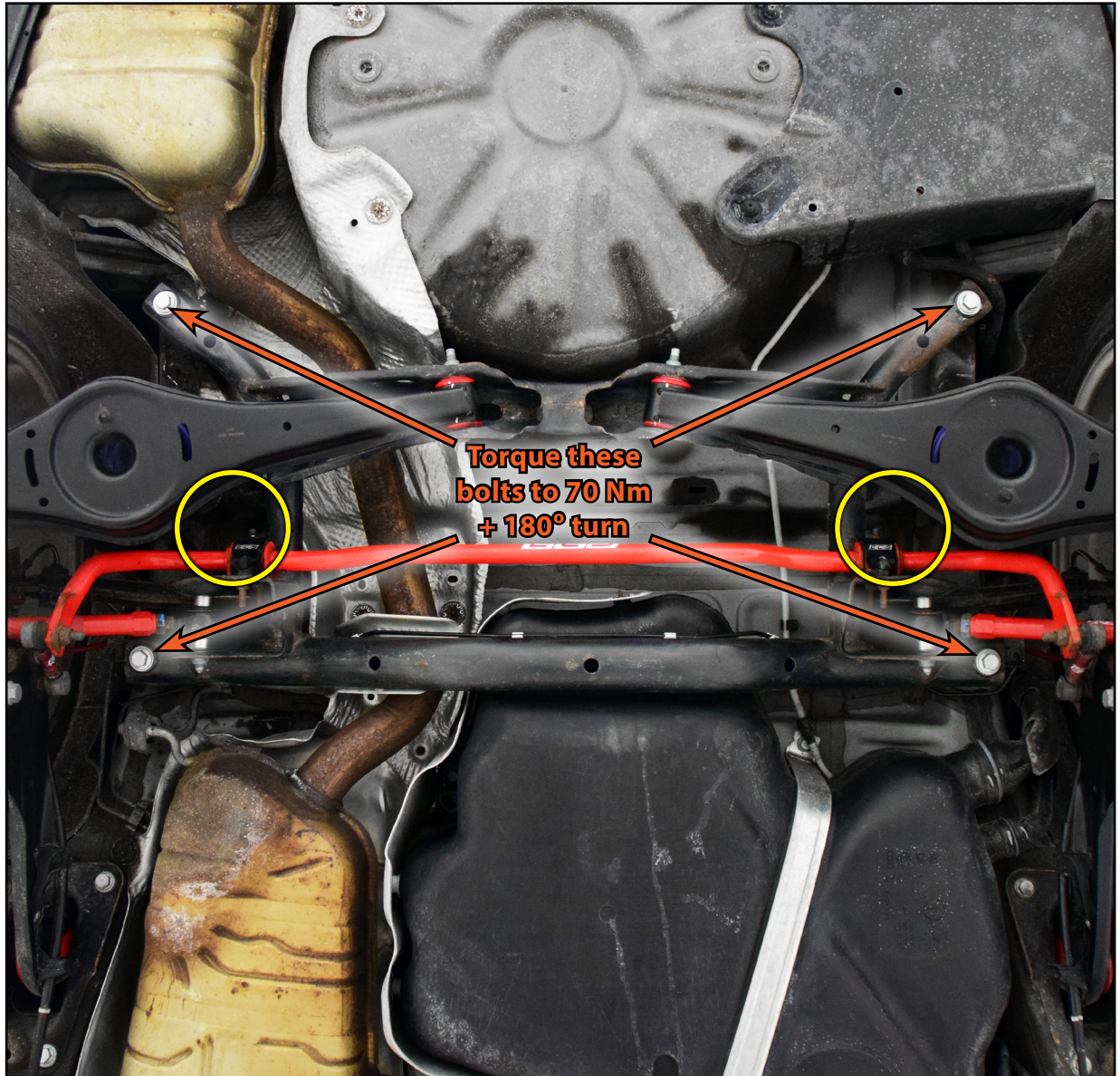



## Your Subframe Locking Collar Kit installation is complete!



### **These instructions are provided as a courtesy by ECS Tuning**

Proper service and repair procedures are vital to the safe, reliable operation of all motor vehicles as well as the personal safety of those performing the repairs. Standard safety procedures and precautions (including use of safety goggles and proper tools and equipment) should be followed at all times to eliminate the possibility of personal injury or improper service which could damage the vehicle or compromise its safety.

Although this material has been prepared with the intent to provide reliable information, no warranty (express or implied) is made as to its accuracy or completeness. Neither is any liability assumed for loss or damage resulting from reliance on this material. SPECIFICALLY, NO WARRANTY OF MERCHANTABILITY, FITNESS FOR A PARTICULAR PURPOSE OR ANY OTHER WARRANTY IS MADE OR TO BE IMPLIED WITH RESPECT TO THIS MATERIAL. In no event will ECS Tuning, Incorporated or its affiliates be liable for any damages, direct or indirect, consequential or compensatory, arising out of the use of this material.