



BMW G30 B58 Intake System Installation Guide



Proper service and repair procedures are vital to the safe, reliable operation of all motor vehicles as well as the personal safety of those performing the repairs. Standard safety procedures and precautions (including use of safety goggles and proper tools and equipment) should be followed at all times to eliminate the possibility of personal injury or improper service which could damage the vehicle or compromise its safety.

TABLE OF CONTENTS

Installation and Safety Information [pg.3](#)
Removing the Stock Intake System [pg.4](#)
Installing the New Intake System [pg.7](#)

AVAILABLE KITS



G30 B58 Carbon Fiber Intake

INSTALLATION NOTES

- **RH** refers to the *passenger side* of the vehicle.
- **LH** refers to the *driver side* of the vehicle.
- Always use the proper torque specifications.
- If applicable to this installation, torque specifications will be listed throughout the document and at the end as well.
- Please read all of these instructions and familiarize yourself with the complete process **BEFORE** you begin.

GENERAL PREPARATION AND SAFETY INFORMATION

Turner Motorsport cares about your health and safety, please read the following safety information. This information pertains to automotive service in general, and while it may not pertain to every job you do, please remember and share these important safety tips.

- Park your car in a safe, well lit, level area.
- Shut the engine off and remove the key from the ignition switch.
- Make sure any remote start devices are properly disabled.
- **ALWAYS** wear safety glasses.
- Make sure the parking brake is applied until the vehicle is safely lifted and supported.
- Whether lifting a vehicle using an automotive lift or a hydraulic jack, be sure and utilize the factory specified lift points.
- Lifting a vehicle in an incorrect location can cause damage to the suspension/running gear.
- **ALWAYS** support the vehicle with jack stands.
- **ALWAYS** read and follow all safety information and warnings for the equipment you are using.



NEVER get underneath a vehicle that is supported only by a jack, and **ALWAYS** make sure that the vehicle is securely supported on jack stands.

REMOVING THE STOCK INTAKE SYSTEM

Step 1: Trim Removal Tool

Remove the plastic push rivets (arrows), then remove the RH plastic cover.

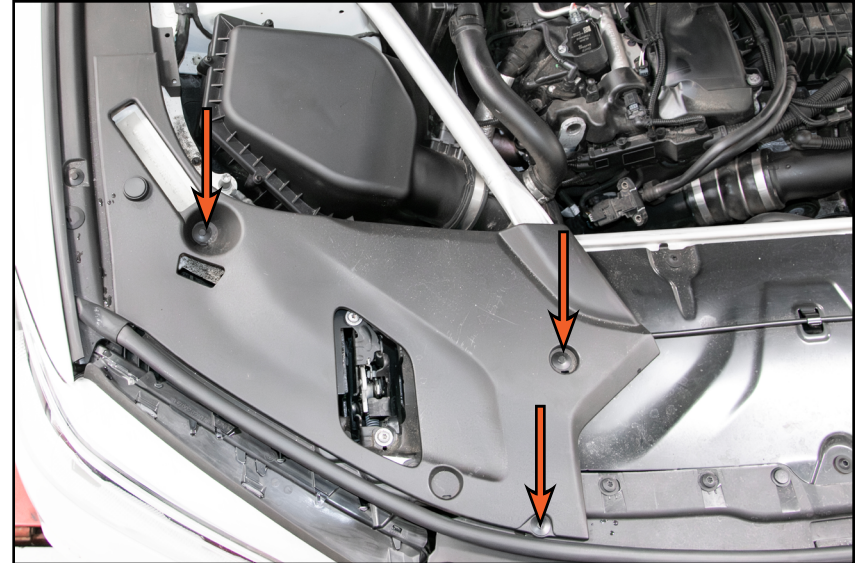

Step 2: E16, 16mm Socket & Ratchet

Remove the two bolts (circled in **RED**), then remove the RH strut brace.

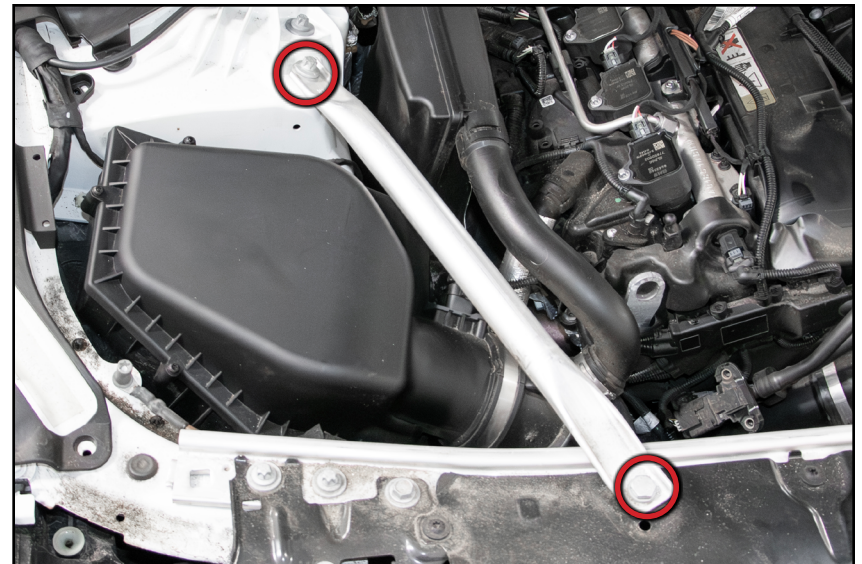

REMOVING THE STOCK INTAKE SYSTEM

Step 3:

Disconnect the MAF sensor connector (highlighted in **RED**).

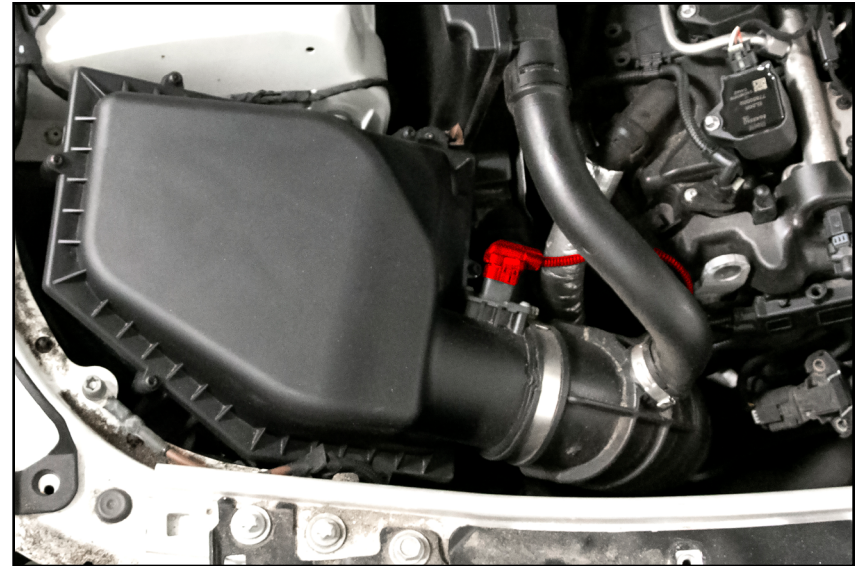

Step 4: 6mm Socket & Ratchet - OR- Flat Blade Screwdriver

Loosen the clamp (arrow in inset photo), then slide the intake tube off of the turbo inlet.

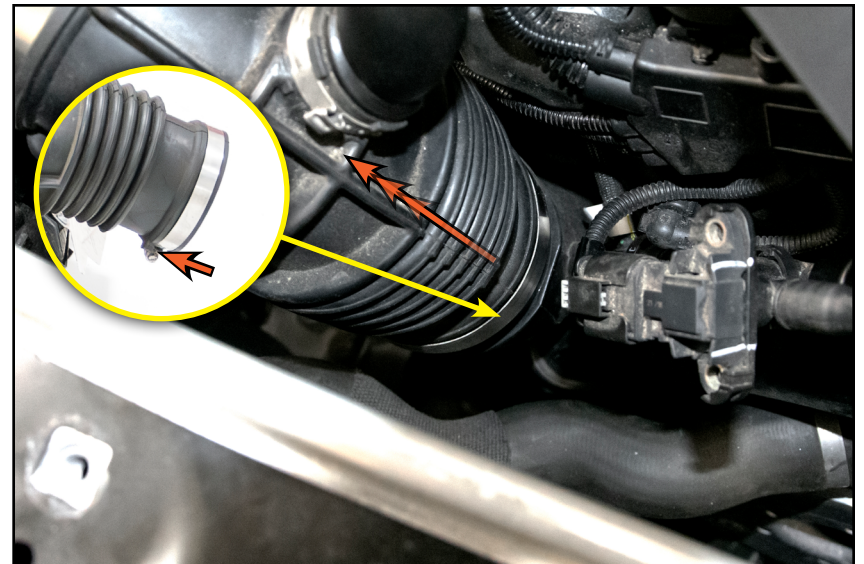

REMOVING THE STOCK INTAKE SYSTEM

Step 5:

Lift upward on the intake resonator and the air box to free them from their grommets. Remove the air box, intake tube, and resonator as one assembly.



INSTALLING THE NEW INTAKE SYSTEM

Step 1:

Install the two aluminum standoffs into the heat shield and bracket with the provided hardware (**YELLOW** inset photo).

Install the three air box lid support brackets and grommets onto the heat shield using the supplied M5 x 12mm bolts (**BLUE** inset photo).

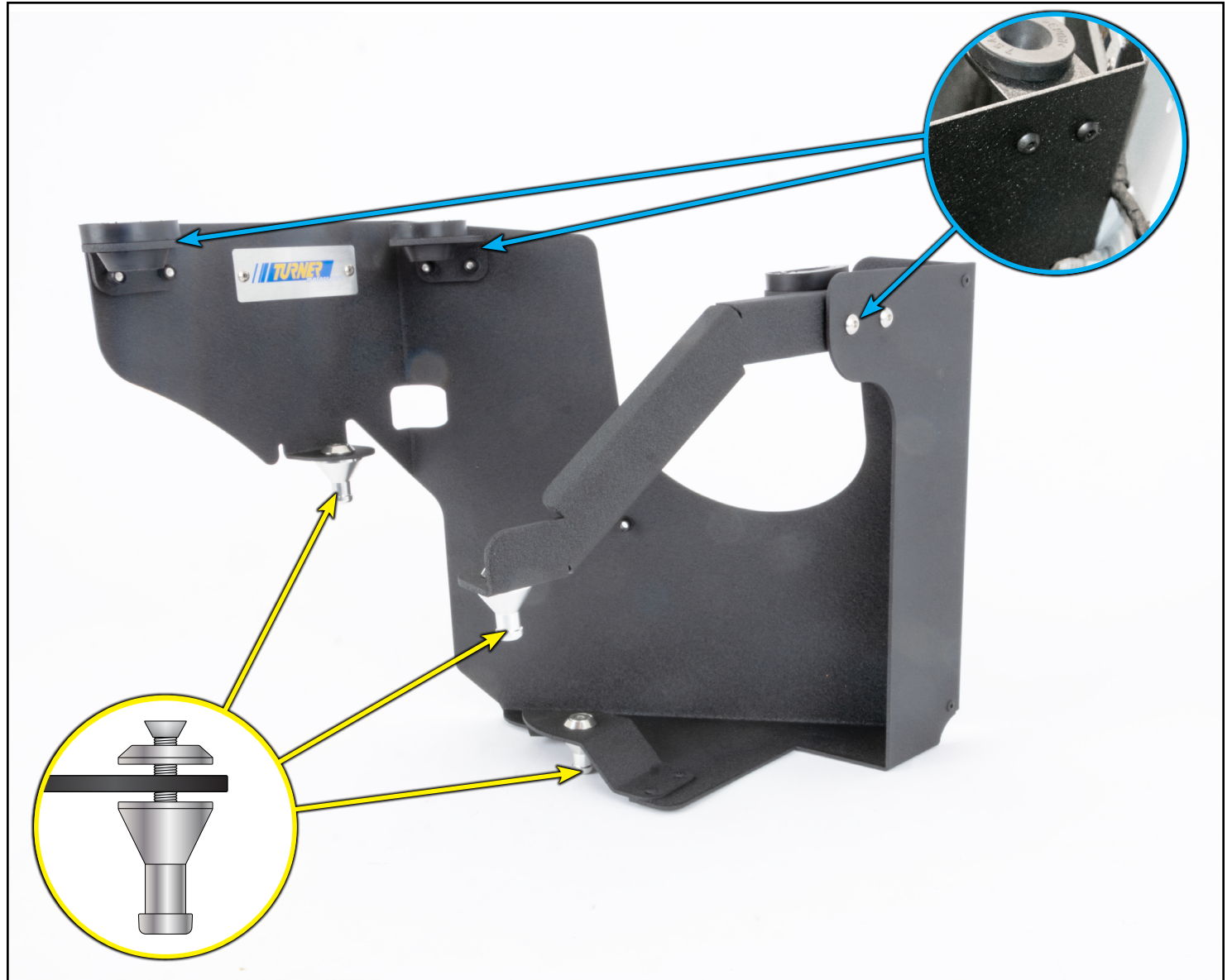

INSTALLING THE NEW INTAKE SYSTEM

Step 2: 7mm Socket & Ratchet

Slide the provided clamps onto the silicone coupler (as shown in **photo #1**), then install the silicone coupler onto the turbo inlet and tighten the clamp (highlighted **GREEN** in **photo 2**) until snug to secure it in place.

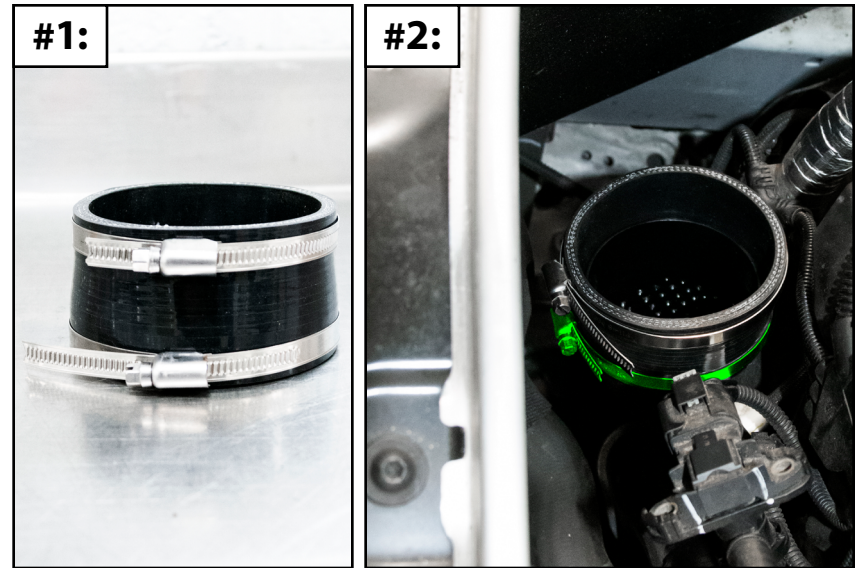

Step 3: T15 Torx, 3mm Hex (Allen)

Remove the screws (arrows in **photo #1**) that secure the mass airflow sensor to the OE airbox. Remove the MAF, install it into the new intake tube (**photo #2**), and secure it with the provided M5 screws.

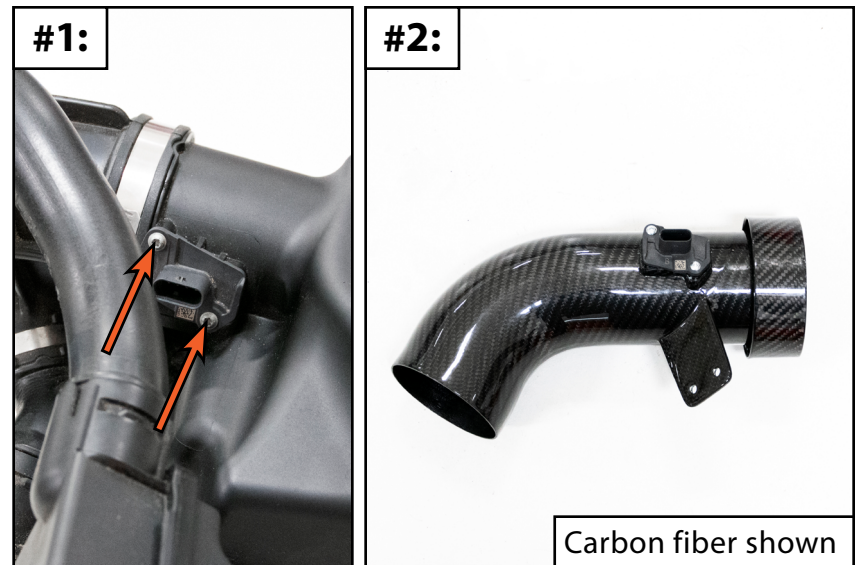

INSTALLING THE NEW INTAKE SYSTEM

Step 4:

Install the heat shield by aligning the standoffs with the grommets and pushing down to pop them into place.

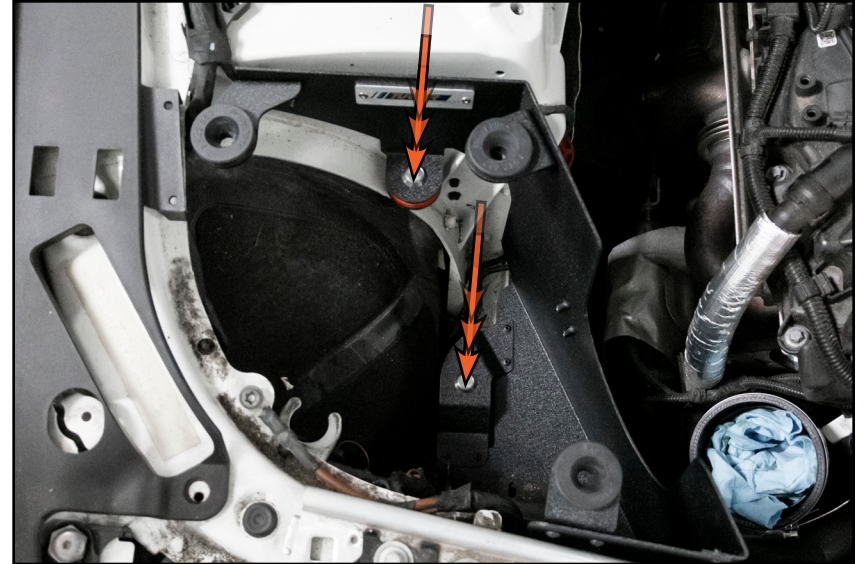

Step 5:

Slide the intake tube into the silicone coupler.

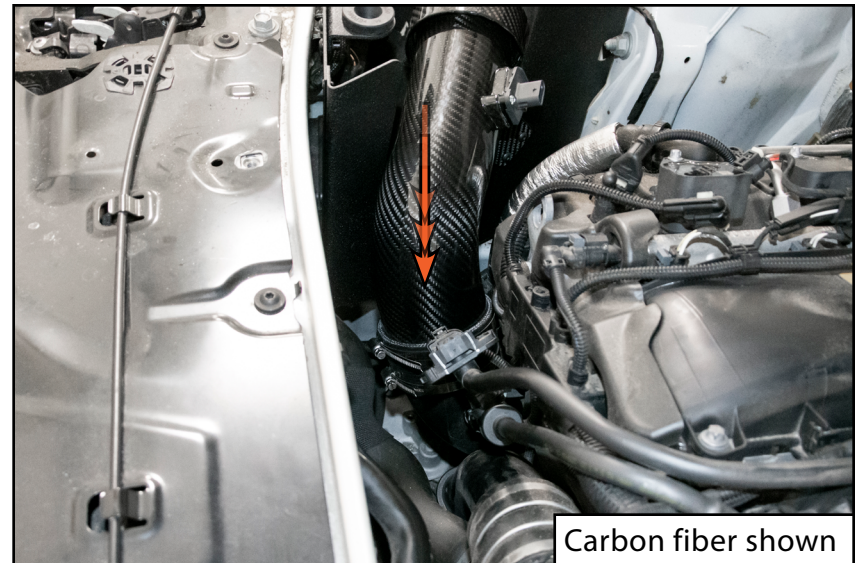

INSTALLING THE NEW INTAKE SYSTEM

Step 6:

Secure the intake tube to the heat shield using the provided M5 x 16mm bolts (arrows in inset photo). Reconnect the MAF sensor harness (highlighted in **GREEN**). Install the air filter onto the intake tube and tighten the clamp until snug. Tighten the upper clamp on the silicone coupler

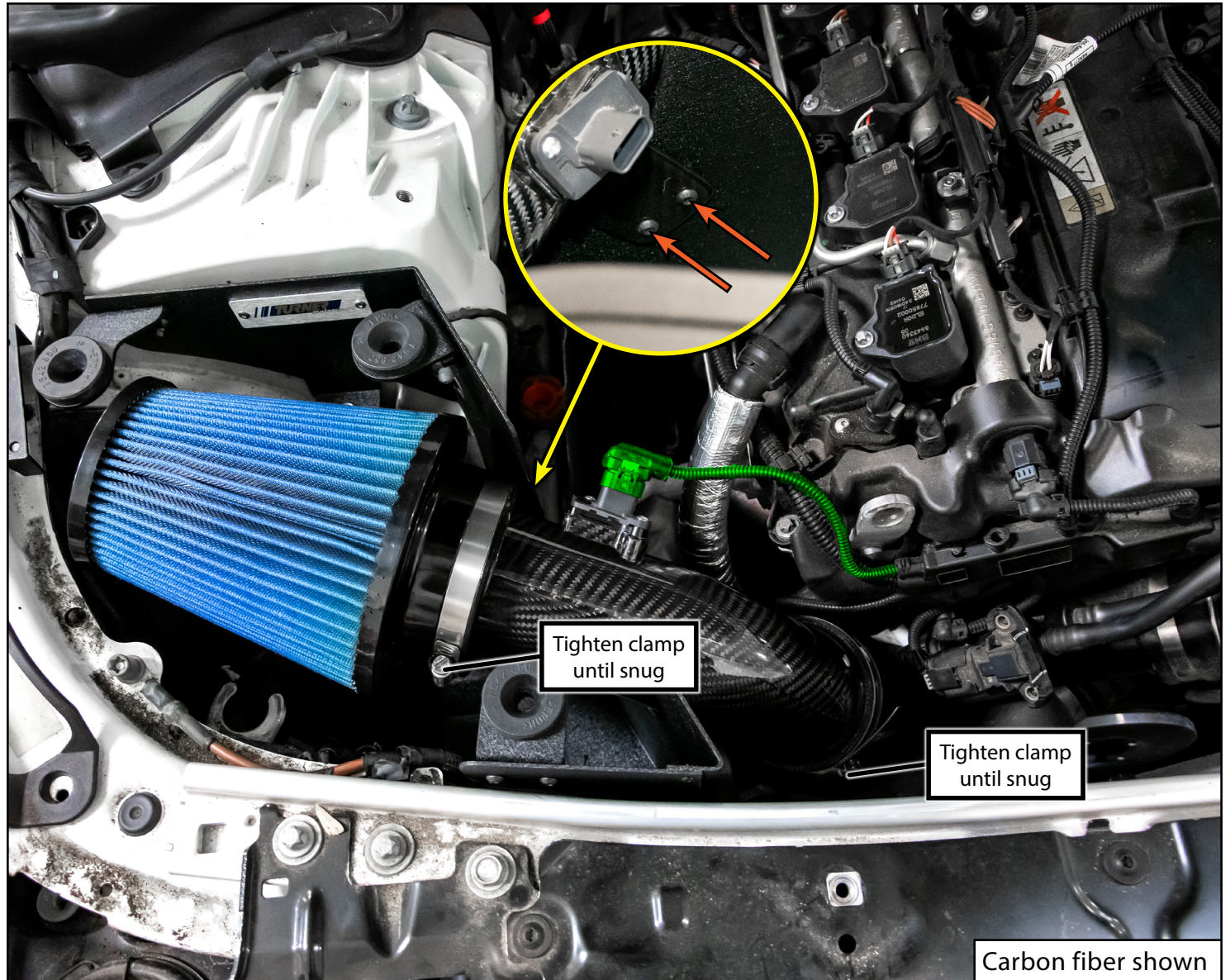

INSTALLING THE NEW INTAKE SYSTEM

Step 7: E16 Torx, 16mm Socket & Torque Wrench

Reinstall the RH strut brace, torquing the bolts (circled in **YELLOW**) to 19 Nm (14 Ft-lbs).

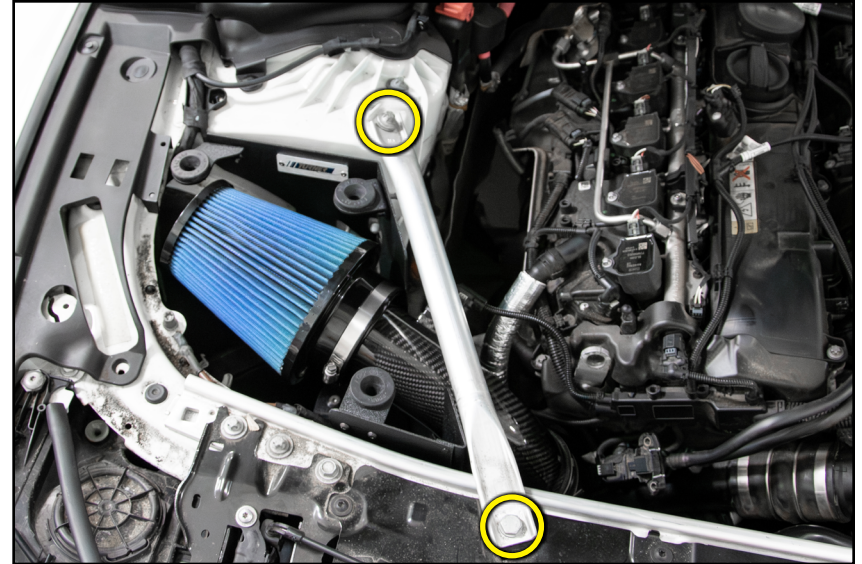

Step 8:

Reinstall the RH plastic cover and secure it in place with the plastic push rivets (arrows).

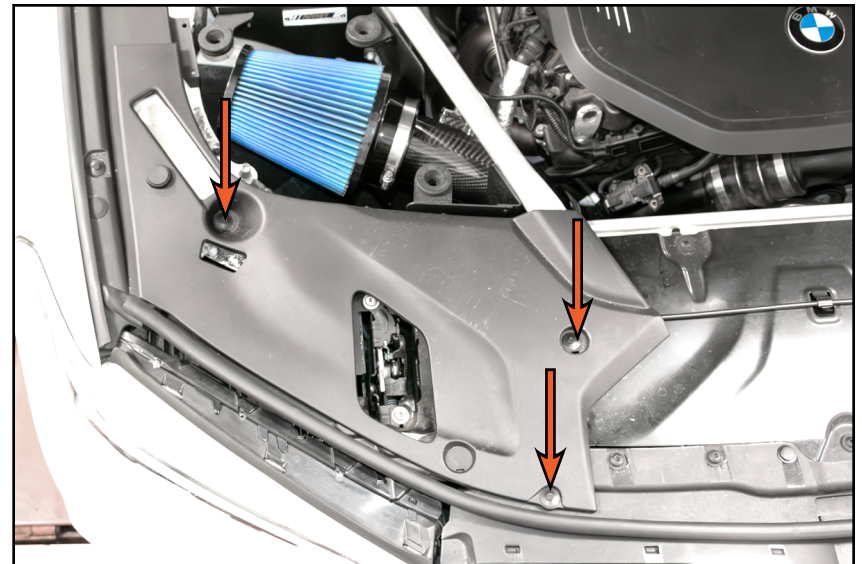

INSTALLING THE NEW INTAKE SYSTEM

Step 9:

Align the carbon fiber lid support posts with the heat shield grommets, then push the lid down until it pops into place.

***Congratulations,
your installation is
complete!***



Your Intake System installation is complete!



These instructions are provided as a courtesy by Turner Motorsport

Proper service and repair procedures are vital to the safe, reliable operation of all motor vehicles as well as the personal safety of those performing the repairs. Standard safety procedures and precautions (including use of safety goggles and proper tools and equipment) should be followed at all times to eliminate the possibility of personal injury or improper service which could damage the vehicle or compromise its safety.

Although this material has been prepared with the intent to provide reliable information, no warranty (express or implied) is made as to its accuracy or completeness. Neither is any liability assumed for loss or damage resulting from reliance on this material. SPECIFICALLY, NO WARRANTY OF MERCHANTABILITY, FITNESS FOR A PARTICULAR PURPOSE OR ANY OTHER WARRANTY IS MADE OR TO BE IMPLIED WITH RESPECT TO THIS MATERIAL. In no event will Turner Motorsport, Incorporated or its affiliates be liable for any damages, direct or indirect, consequential or compensatory, arising out of the use of this material.