



Skill Level 1 - Easy

# BMW G80/G82 M3, M4 Skid Plate Installation Instructions



**Thank you for purchasing your new Turner Motorsport Skid Plate, we appreciate your business!**



### Sleek and durable:

- Our skid plates are constructed of durable 8 gauge 5052 aluminum capable of withstanding multiple impacts without fear of damaging the oil cooler.

### Flawless Finish:

- Our skid plates are available in a raw milled finish or in a gorgeous wrinkle black powder coated finish.



### Easy Installation:

- Installation is quick and easy! Our skid plates require no modification to the vehicle.

Proper service and repair procedures are vital to the safe, reliable operation of all motor vehicles as well as the personal safety of those performing the repairs. Standard safety procedures and precautions (including use of safety goggles and proper tools and equipment) should be followed at all times to eliminate the possibility of personal injury or improper service which could damage the vehicle or compromise its safety.

## Section 1: Removing the Stock Belly Pan

- Step #1** • Remove the 11x screws (arrows) and remove the plastic belly pan retainer (highlighted in **RED**).
- Step #2** • Remove the 14x screws (arrows) and remove the stock belly pan (highlighted in **RED**) from the underside of the vehicle. Remove the rubber edge trim from the oil cooler.

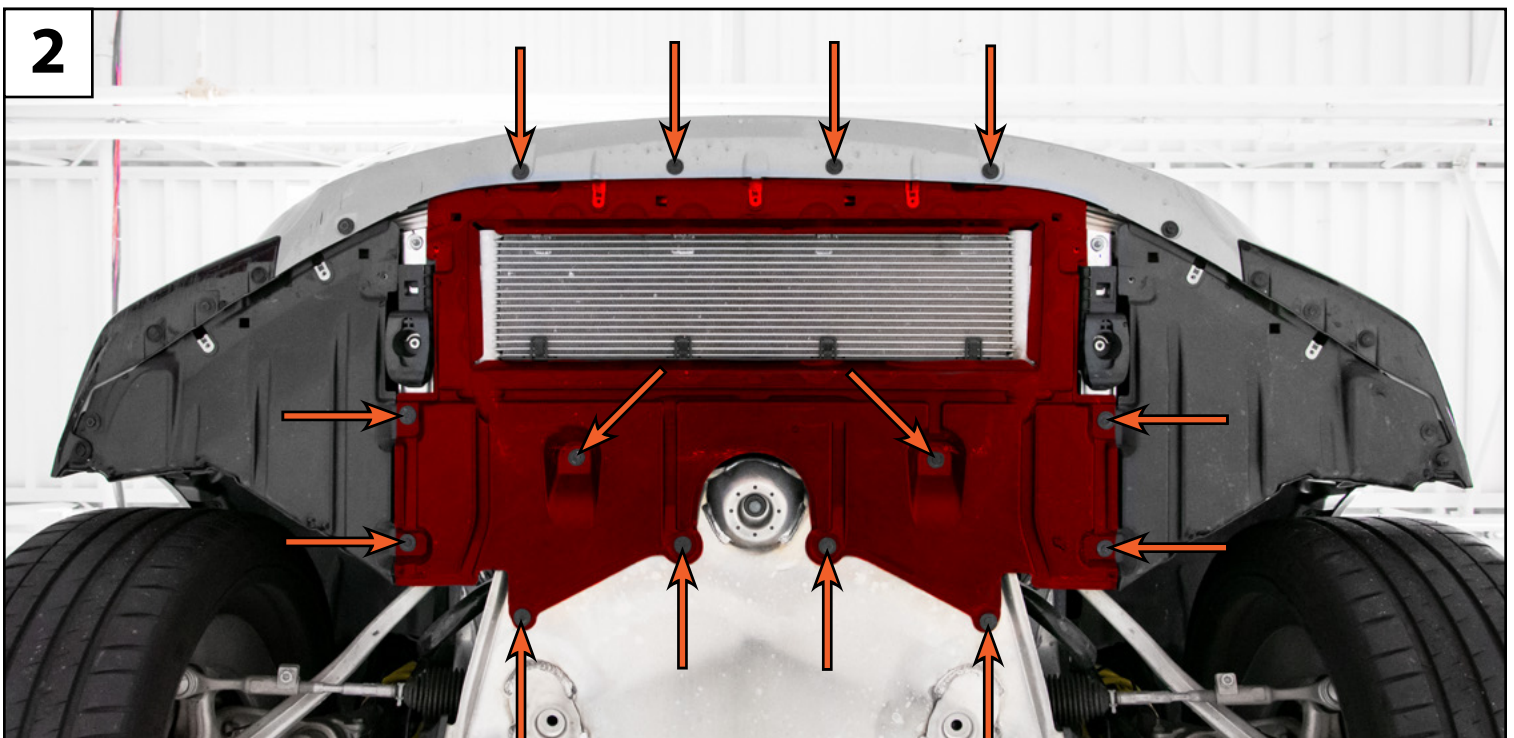
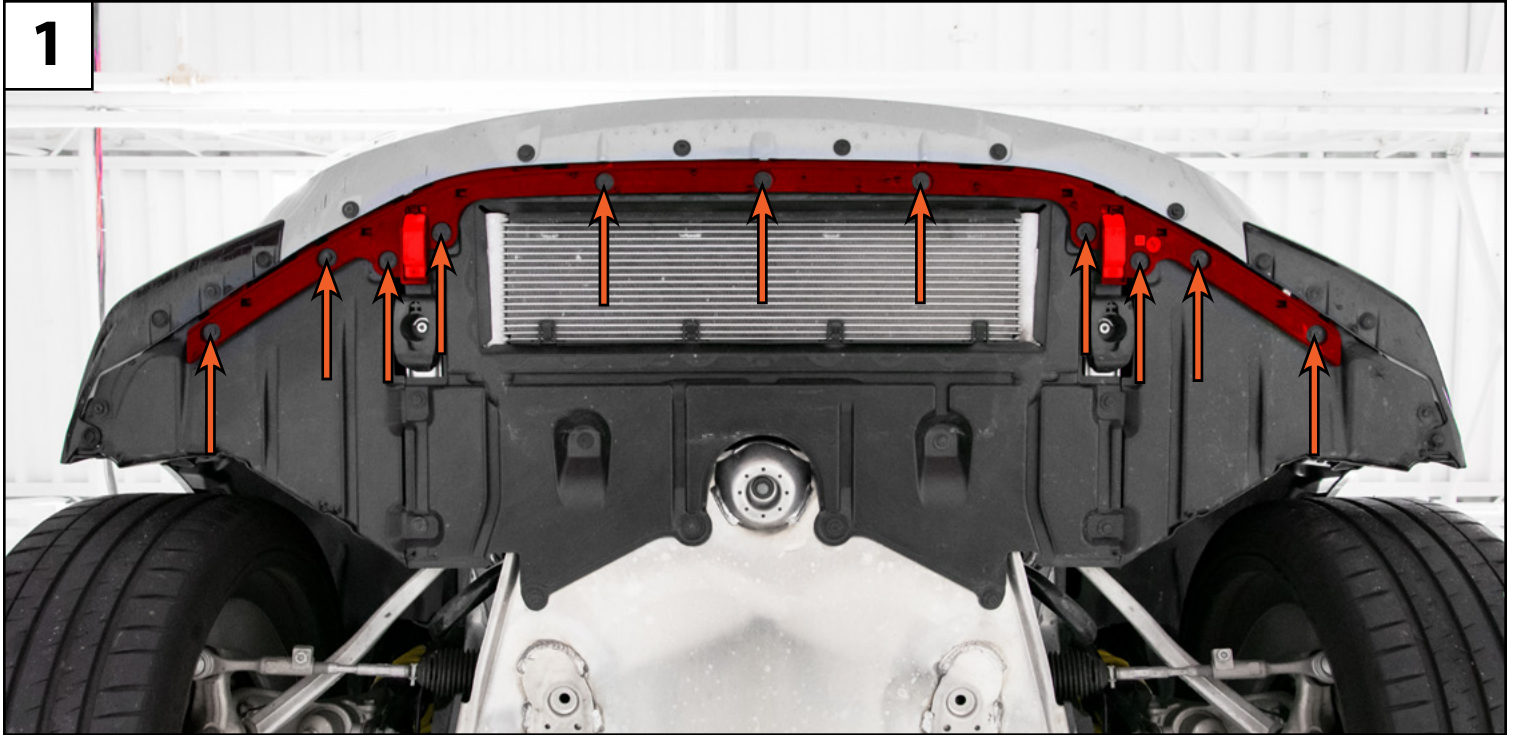



## Section 1: Removing the Stock Belly Pan

- Step #3** • Remove the three screws (arrows) which secure each belly pan side panel (highlighted in **RED**) to the fender liner.
- Step #4** • Remove the three remaining screws from the front of each side panel, then remove the panels from the vehicle.

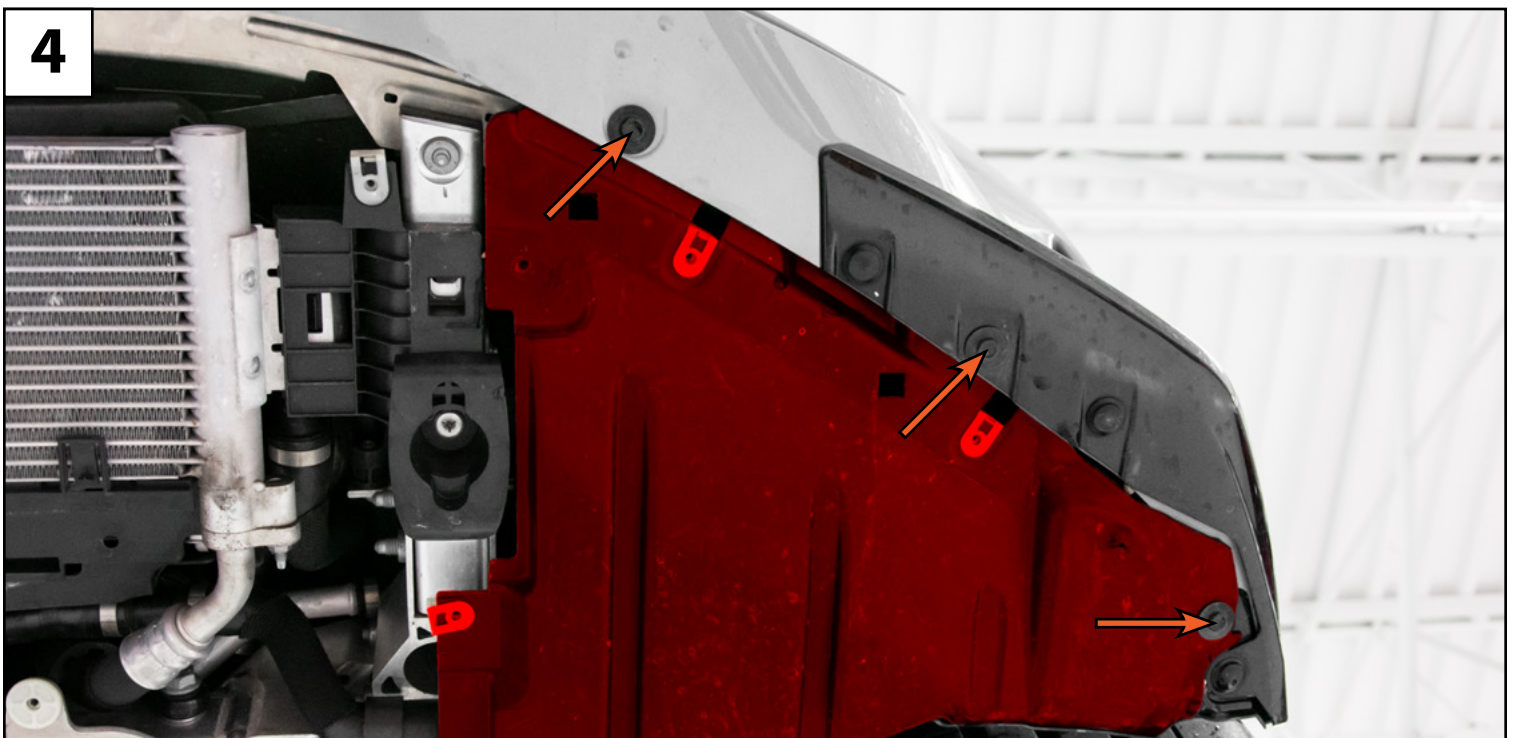
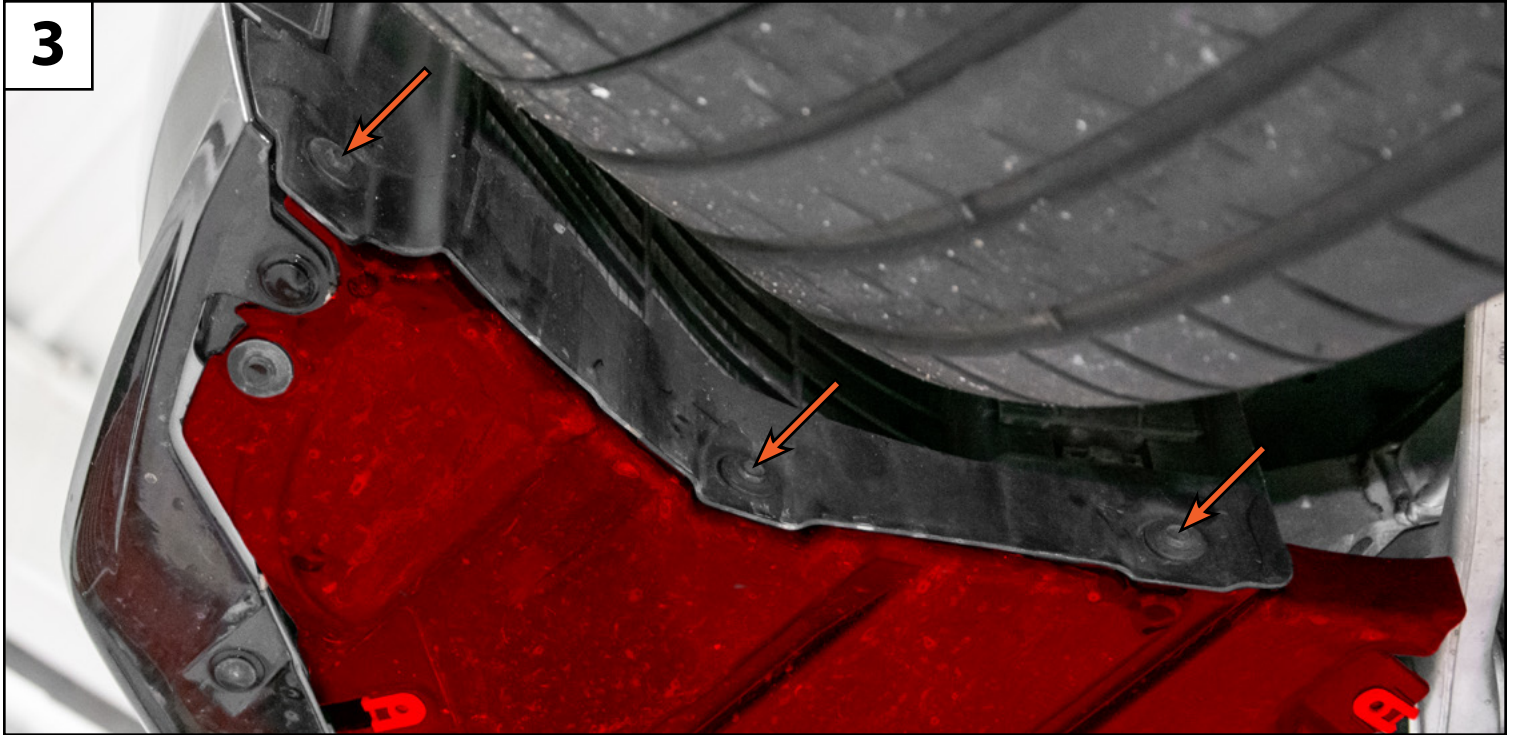

## Section 2: Installing the New Skid Plate

- Step #1** • Lift each of the new side plates up into place, install two of the provided M6 x 20mm screws (circled in **YELLOW**), then reinstall three of the OE screws (arrows) as shown.
- Step #2** • Install two of the provided M6 x 20mm screws (circled in **YELLOW**) to secure the fender liner to the side plate, then reinstall one of the OE screws (arrows) as shown.

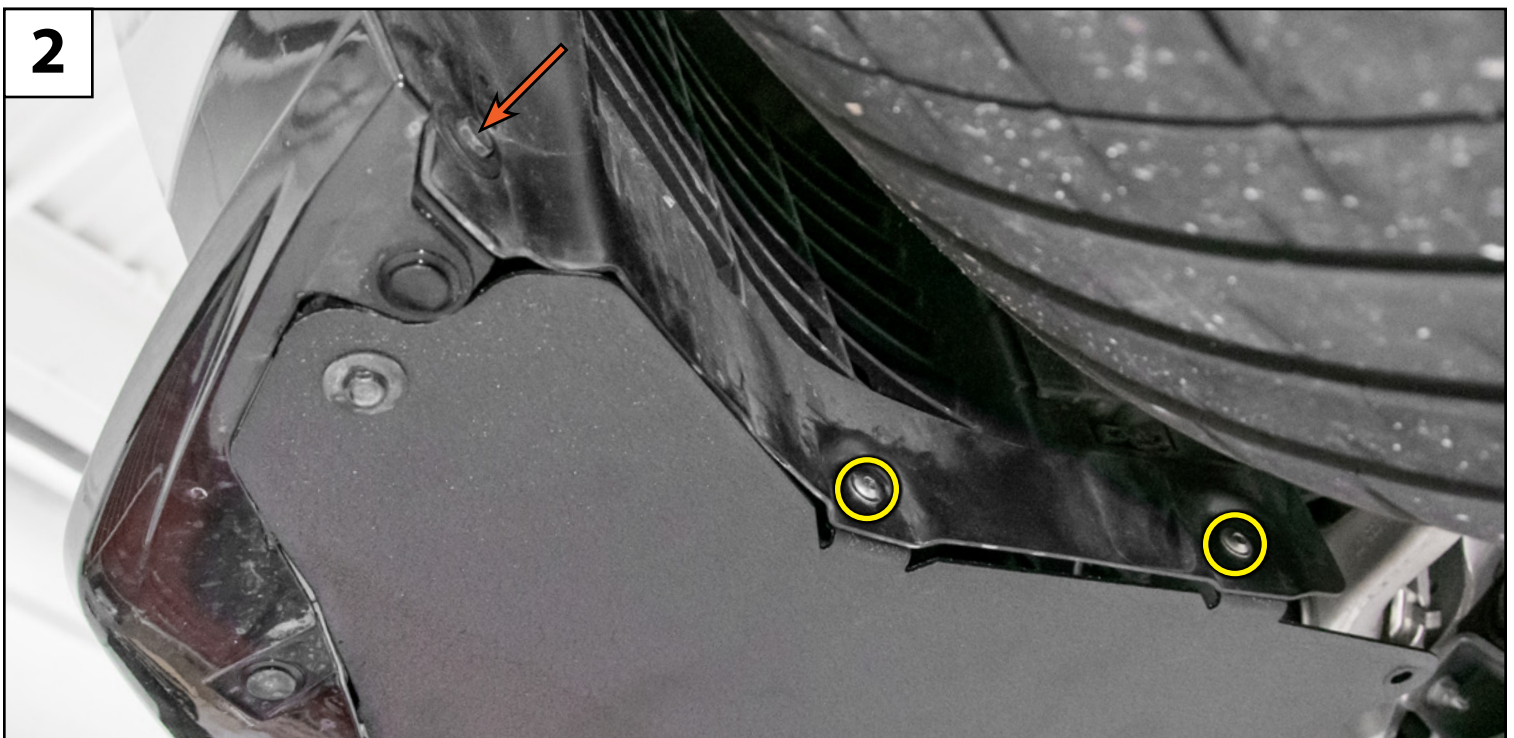
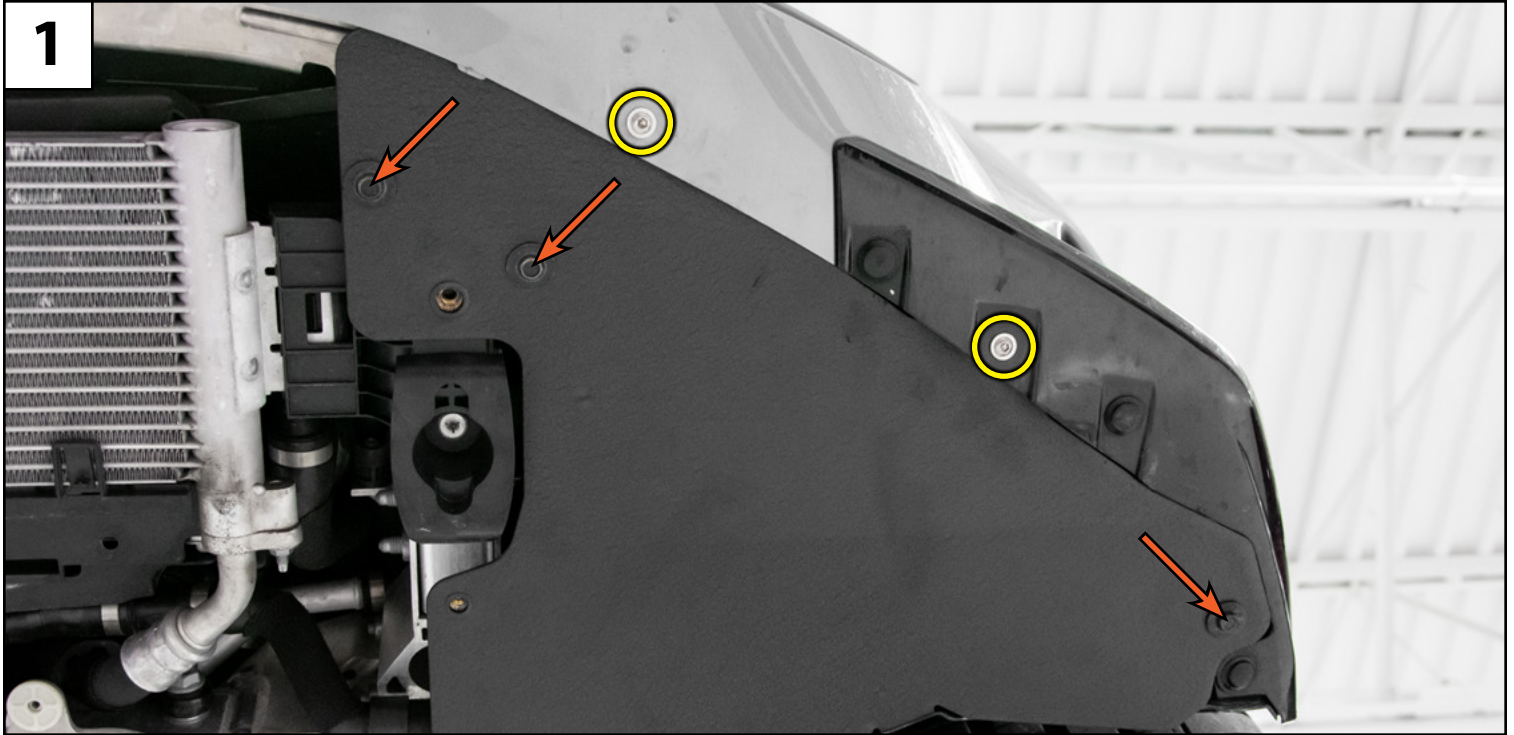



## Section 2: Installing the New Skid Plate

- Step #3** • Lift the new skid plate into place, then install the two provided M8 x 25mm screws (circled in **BLUE**) to secure it up into place. Install the eight remaining M6 x 20mm screws (circled in **YELLOW**), then reinstall four of the OE screws (arrows) as shown.

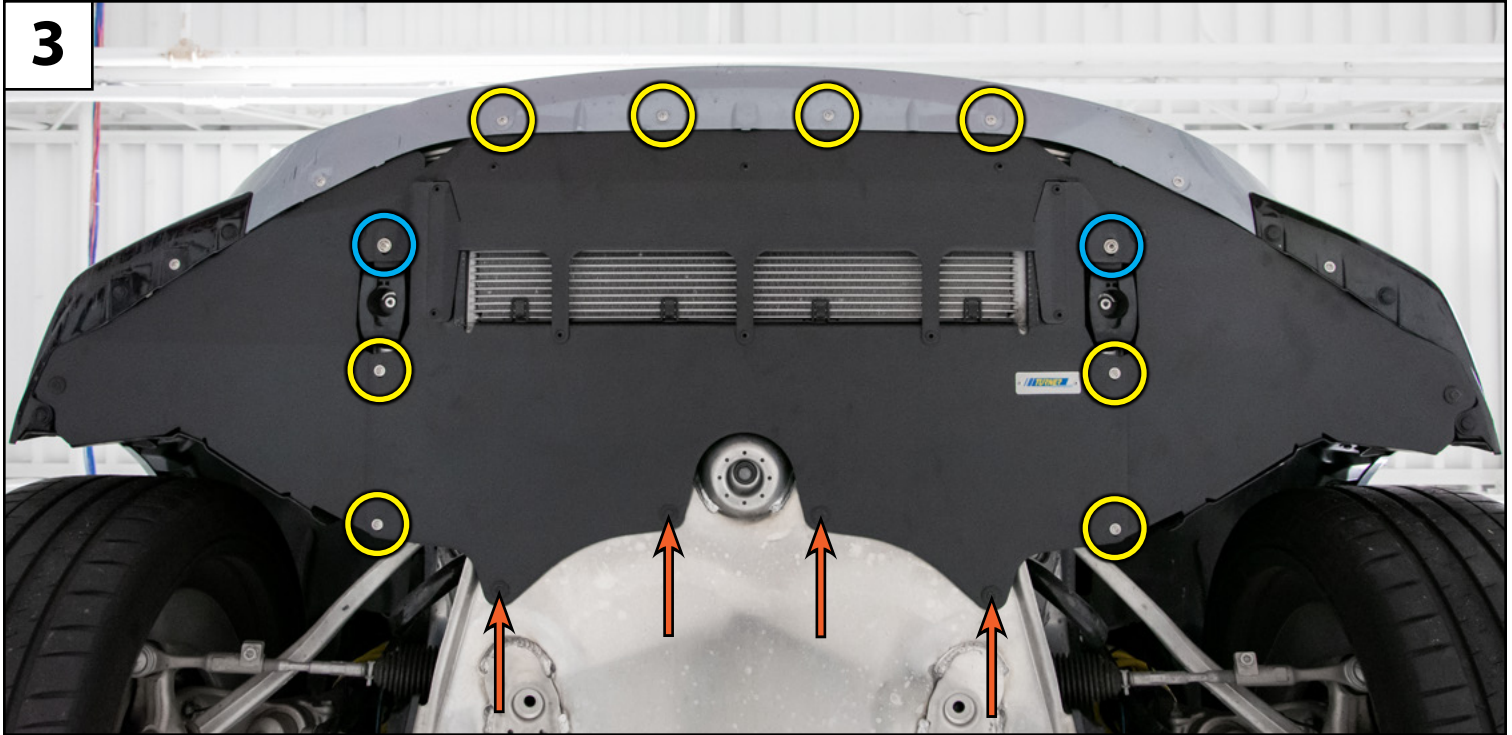

***Congratulations, your installation is complete!***