

ECS TUNING®

Tool Instructions



ES2190252
(8 piece kit)



Wiper Arm Extractor Set

This tutorial is provided as a courtesy by ECS Tuning.

Proper service and repair procedures are vital to the safe, reliable operation of all motor vehicles as well as the personal safety of those performing the repairs. Standard safety procedures and precautions (including use of safety goggles and proper tools and equipment) should be followed at all times to eliminate the possibility of personal injury or improper service which could damage the vehicle or compromise its safety.

Although this material has been prepared with the intent to provide reliable information, no warranty (express or implied) is made as to its accuracy or completeness. Neither is any liability assumed for loss or damage resulting from reliance on this material. SPECIFICALLY, NO WARRANTY OF MERCHANTABILITY, FITNESS FOR A PARTICULAR PURPOSE OR ANY OTHER WARRANTY IS MADE OR TO BE IMPLIED WITH RESPECT TO THIS MATERIAL. In no event will ECS Tuning, Incorporated or its affiliates be liable for any damages, direct or indirect, consequential or compensatory, arising out of the use of this material.

Wiper Arm Extractor Set

Schwaben® ES2190252



Product Description

The Schwaben® Wiper Arm Extractor easily removes press-fit wiper arms, including those that are corroded in place.

Kit Contents

The kit includes:

- pressure spindle
- slide hammer
- six gripper heads to fit wiper arms on popular European makes

Applications:

The gripper heads fit the following makes:

- Alfa Romeo • Audi • BMW • Citroen • Fiat • Ford • Honda • Jaguar • Mazda
- MG-Rover • Mitsubishi • Chevrolet • Peugeot • Renault • Volvo • VW • Mercedes

The pressure spindle pushes against the wiper arm drive shaft in most applications.



The slide hammer removes wiper arms with no center shaft.



Six different grippers provide wide coverage for many Euro-vehicle wiper arms.



Wiper Arm Extractor Set

Schwaben® ES2190252



Using the Tool

- Use the application sheet in the kit to select the correct gripper head for the vehicle.
- Lift or remove the protective cover to expose the nut that secures the wiper arm to the wiper shaft.

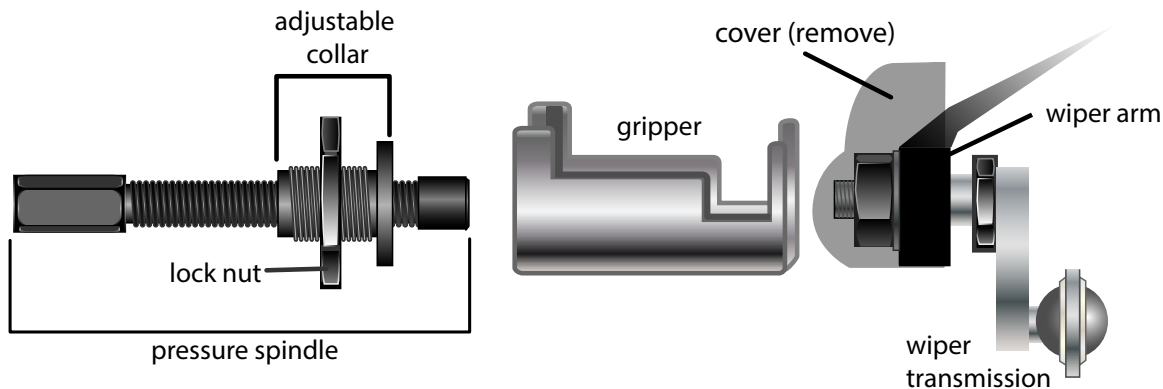

- Assemble the tool as shown below. Back off the lock nut on the collar far enough to insert the collar into the gripper. Tighten the locknut to secure the gripper on the collar.
- Slip the gripper jaw around the base of the wiper arm, then turn the threaded spindle head by hand until the head of the pressure spindle contacts the wiper shaft.
- Using a wrench, continue to turn the threaded shaft on the pressure spindle until the gripper pulls the wiper arm off the wiper shaft.

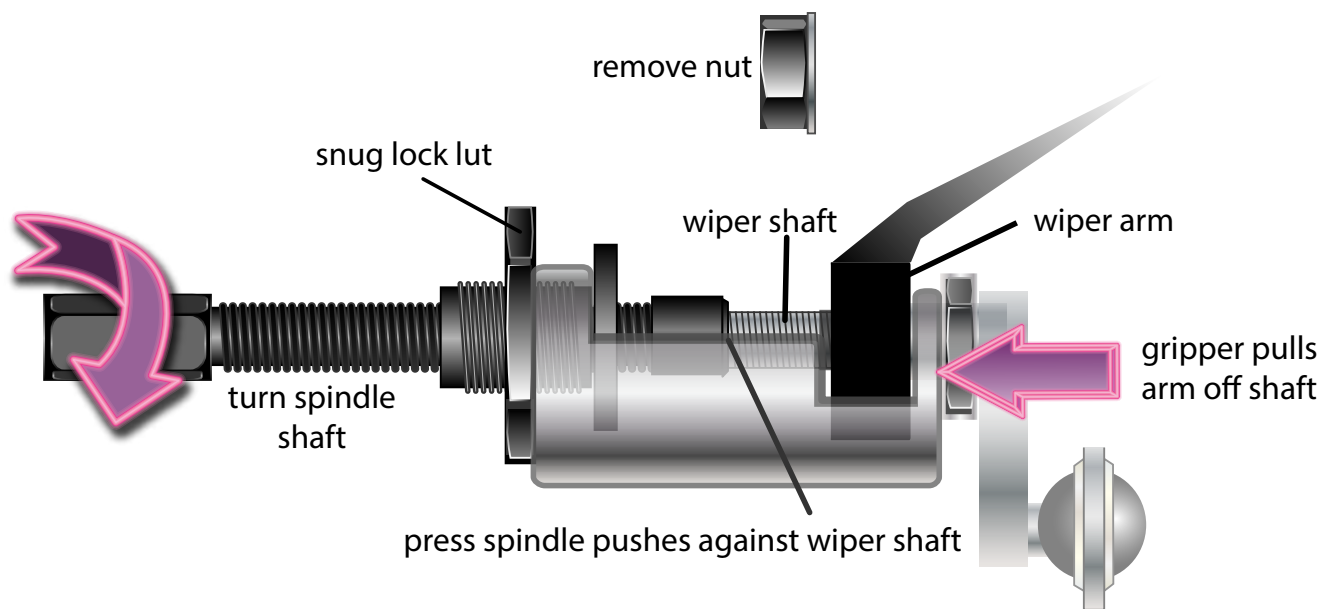

Click the image to order your Wiper Arm Removal Tool at the ECS Tuning web site.