

# ECS TUNING®

## Brake Piston Retractor Tools



ES9747

(11 Piece)

ES2153340

(18 Piece)



## Rear Brake Caliper Piston Tools

This tutorial is provided as a courtesy by ECS Tuning.

Proper service and repair procedures are vital to the safe, reliable operation of all motor vehicles as well as the personal safety of those performing the repairs. Standard safety procedures and precautions (including use of safety goggles and proper tools and equipment) should be followed at all times to eliminate the possibility of personal injury or improper service which could damage the vehicle or compromise its safety.

Although this material has been prepared with the intent to provide reliable information, no warranty (express or implied) is made as to its accuracy or completeness. Neither is any liability assumed for loss or damage resulting from reliance on this material. SPECIFICALLY, NO WARRANTY OF MERCHANTABILITY, FITNESS FOR A PARTICULAR PURPOSE OR ANY OTHER WARRANTY IS MADE OR TO BE IMPLIED WITH RESPECT TO THIS MATERIAL. In no event will ECS Tuning, Incorporated or its affiliates be liable for any damages, direct or indirect, consequential or compensatory, arising out of the use of this material.

# Rear Brake Piston Tools

Schwaben® ES9747 and ES2153340



## Product Description

Schwaben® Brake Caliper Piston Retractor Tools screw rear brake caliper pistons into the caliper to make room for new, thicker brake pads.

Brake calipers with hand brake mechanisms commonly screw the brake piston out as the pads wear. This process is gradual, and keeps the hand brake adjusted.

Before installing new pads you must first screw the piston in again to make room. To make this fast and easy, Schwaben Brake Caliper Piston Retractor kits include several press heads for different size brake pistons, each with raised pins that engage notches in the piston head.

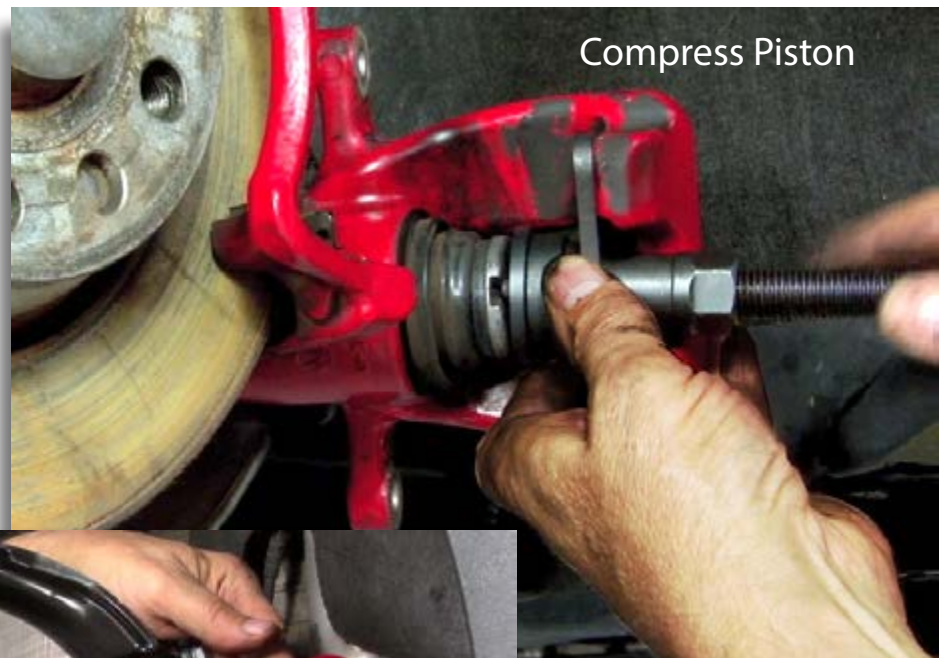

# Rear Brake Piston Tools

## Schwaben® ES9747 and ES2153340



### Kit Contents

#### 11-Piece Kit

The 11-piece kit includes several press heads, a press plate, and a screw jack.

The press heads have different diameters and pin locations to match brake pistons on many common makes, both foreign and domestic.



Both kits include a special adapter (number 5) that accepts a 3/8-inch drive ratchet for use in some applications.

LH screw jack

RH screw jack

#### 18-Piece Kit

The 18-piece kit includes the parts from the 11-piece kit, plus additional press heads and a left-hand screw jack.



# Rear Brake Piston Tools

Schwaben® ES9747 and ES2153340



## Using the Tool

1. Remove the brake caliper from the caliper frame.
2. Remove the brake pads.
3. Slide the press plate over the handle end of the screw jack, onto the adjustment collar.
4. Select the correct press head. Match the press head diameter and pin locations to the notches in the brake piston.
5. Place the press head onto the end of the screw jack. The head of the screw jack is magnetized to hold the press head in place.
6. Insert the tool into the caliper opening with the press plate inside the caliper body, as shown in the illustration.
7. Insert the raised pins into the mating notches in the piston. Then screw the adjustment collar toward the handle until the press plate contacts the caliper.
8. Turn the handle on the jack screw to rotate the piston, screwing it into the caliper body. Continue screwing the piston inward until it is fully compressed.

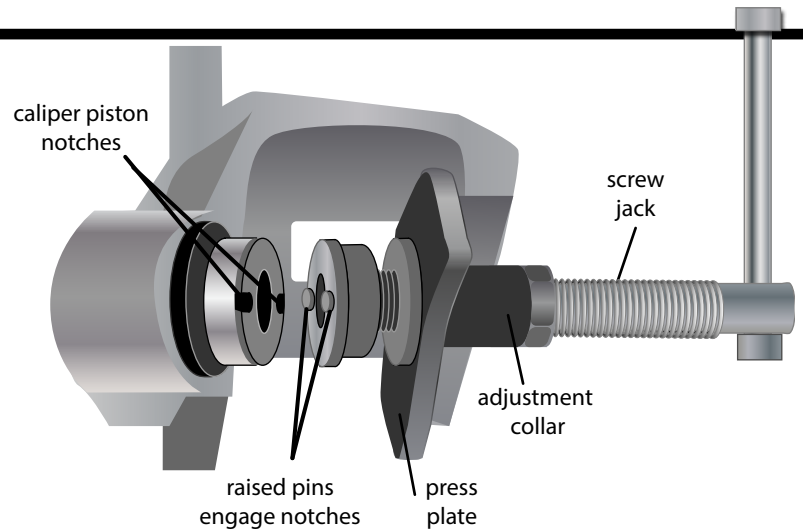

## Notes and Cautions

- Some caliper pistons have a left hand thread. These require the left hand thread screw jack included in the 18-piece kit.
- Reposition the adjustment collar as needed to keep the press head in contact with the piston as you screw it in.
- Cracking the brake bleeder purges old fluid from the caliper as the piston is pushed in. We recommend flushing and bleeding the system as part of the brake service.

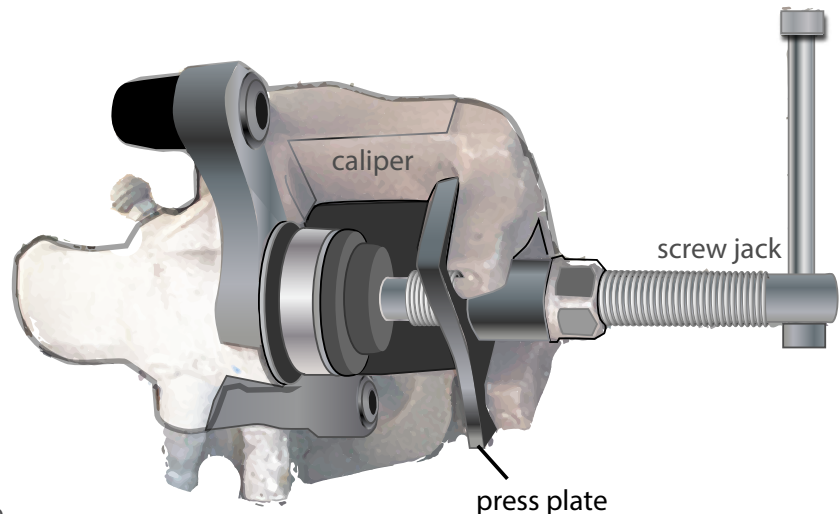

Rear Brake Piston Tools  
Schwaben® ES9747 and ES2153340



Watch our free video.

Click the image below to watch the Schwaben Rear Brake Piston Tool in use in a free video showing how to replace pads and rotors on a MKV GTI.



Thanks for purchasing the  
Schwaben Rear Brake  
Piston Retractor Tool.

